

TABLE OF CONTENTS

SHEET 1-	SITE MAP ROAD MAP
SHEET 2-	SITE PLAN
SHEET 3-	BUILDING PROFILE PIT PROFILE PIT FLOOR PLAN BUILDING FLOOR PLAN
SHEET 4-	SIDE WALL DETAIL END WALL DETAILS 20" COLUMN DETAIL
SHEET 5-	FLATWORK DETAILS CORNER REBAR DETAILS PERIMETER WALL DETAILS 24"Ø PIER DETAILS ROOF RUNOFF COLLECTION DETAIL CURB DETAILS PUMP OUT DETAIL

SHEET 6- CONCRETE AND STRUCTURAL NOTES
CONSTRUCTION JOINT DETAILS
PILASTER DETAILS

SHEET 7- CONCRETE AND STRUCTURAL NOTES
MATERIAL QUANTITIES

***ENGINEERING JOB
CLASS III***

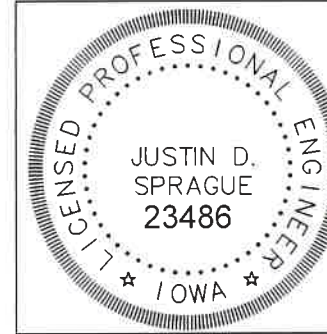

To the best of my professional knowledge, judgement and belief, this design, construction drawings, and specifications meet applicable NRCS Standards and Specifications.
TSP-14-9932

I hereby certify that this engineering document was prepared by me or under my direct personal supervision and that I am a duly licensed Professional Engineer under the laws of the State of Iowa.

Justin D. Sprague, P.E.
23486
Date 5/23/23

My license renewal date is December 31, 2023

Pages or sheets covered by this seal:
SL1-7

CLIENT REVIEW (to be signed at Preconstruction Meeting):
I have reviewed and approve the design and construction drawings.

Date

ISSUED FOR BID
NOT FOR CONSTRUCTION

SHEET 1/7
Project No. 22-058
Checked By JDS
Date 5/31/23
Drawn TMW

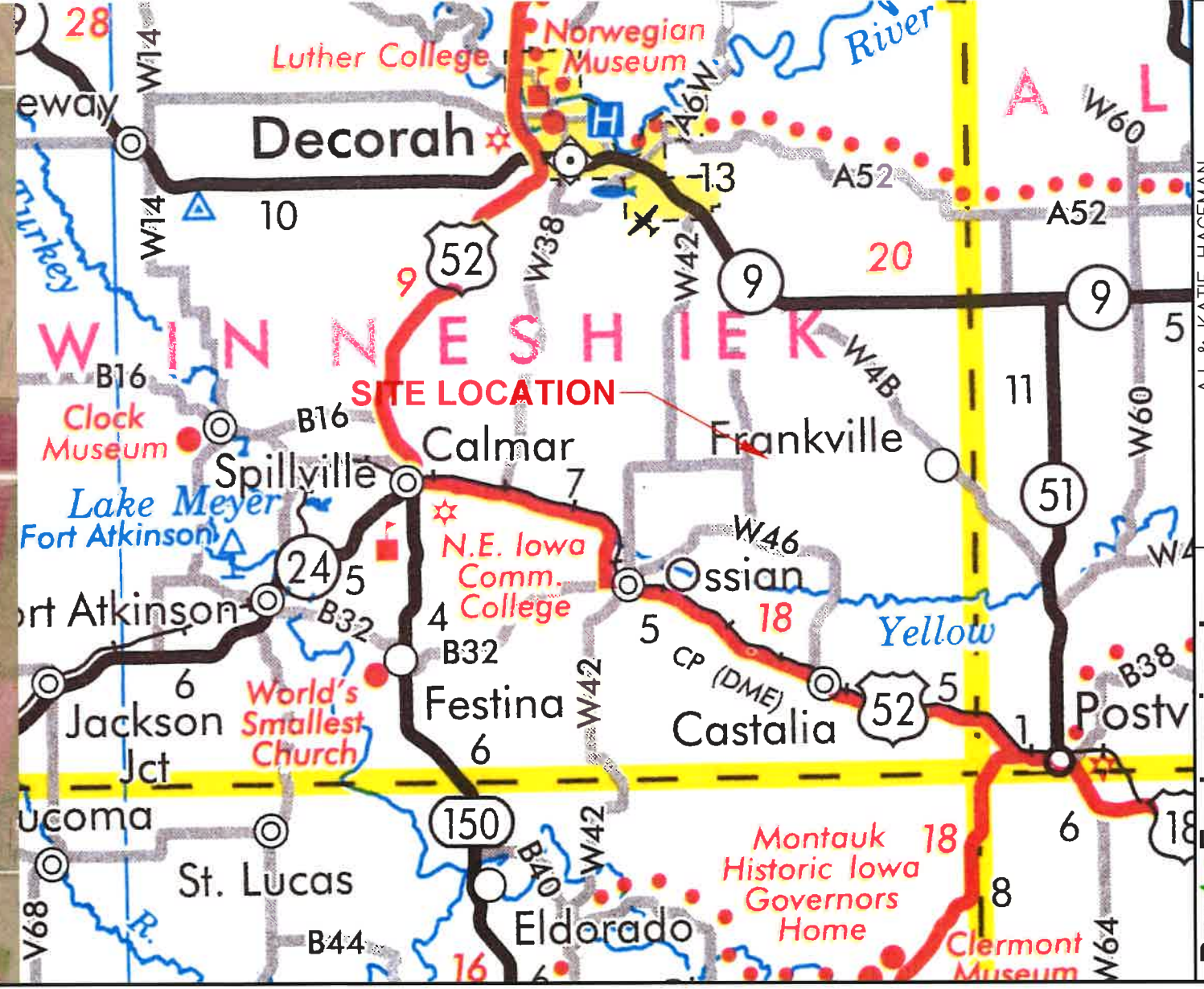
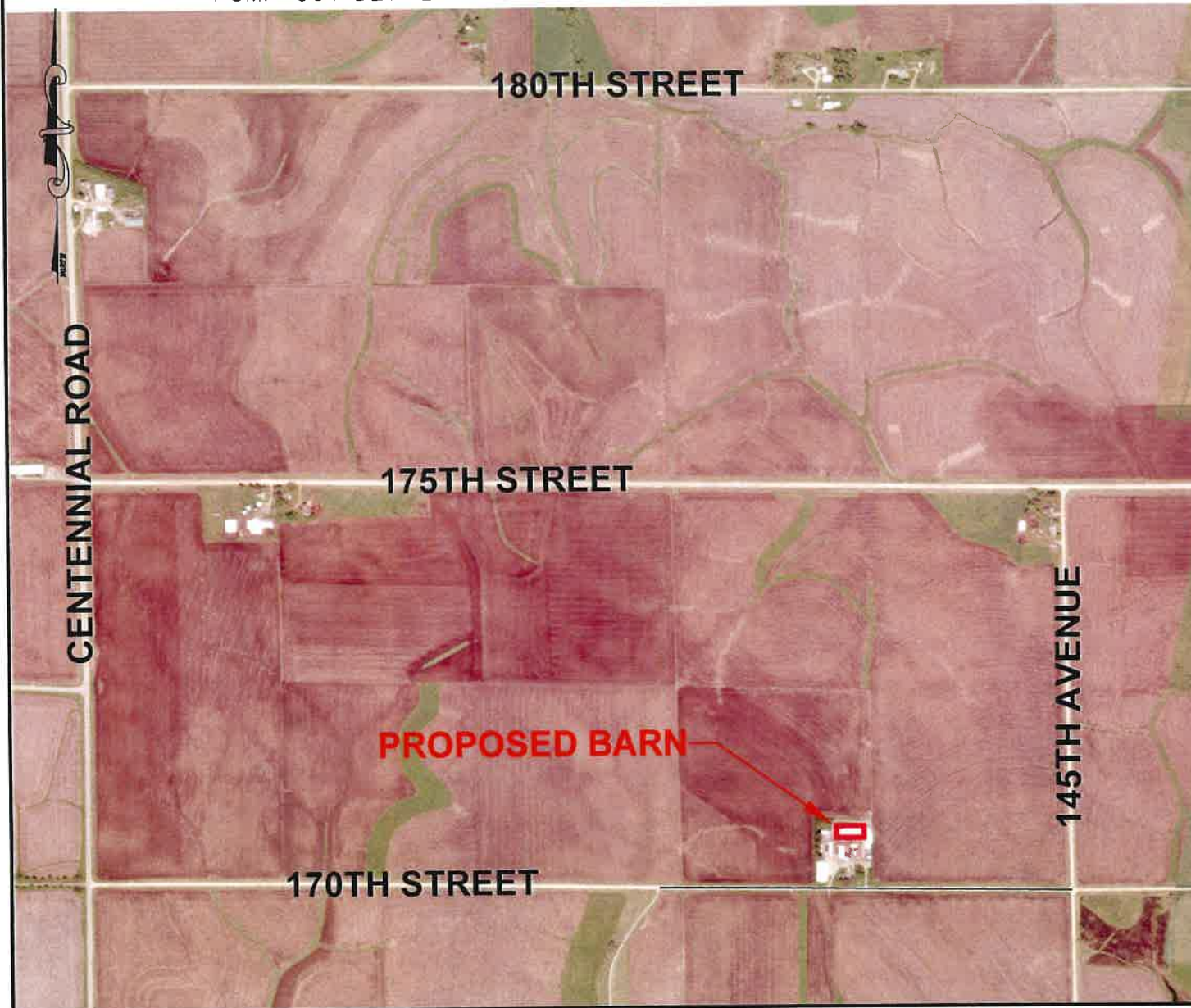

AJ & KATIE HAGEMAN
PROPOSED CATTLE CONFINEMENT BARN
SE 1/4, SECTION 29, T-97-N, R-07-W
WINNESHIEK COUNTY, IOWA

ProAg Engineering, Inc.
77402 U.S. Highway 71, P.O. Box 181
Jackson, MN 56143
(507) 849-7200

GRAPHIC SCALE

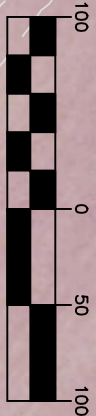

(IN FEET)
1 inch = 100 ft.



- ***PROPOSED NRCS EQP QUANTITIES 5/31/23*****
- 1.) 367 - ROOF & COVERS, ROOF STRUCTURE, >90' = 7,600 SF (7'6" x 100' ROOF OVER BEDDED PACK AREA)
 - 2.) 313 - WASTE STORAGE FACILITY, BEDDED PACK, CONCRETE = 7,600 SF (7'6" x 100' BEDDED PACK AREA)
 - 3.) 313 - WASTE STORAGE FACILITY, CONCRETE TANK = 40,320 CF (84' x 40' x 12' PVT VOLUME)
 - 4.) 561 - HEAVY USE AREA PROTECTION, CONCRETE = 3,700 SF (20' x 185' DROVERS ALLEY)
 - 5.) 558 - ROOF RUNOFF STRUCTURE, ROCK TRENCH = 100 LF (ROOF RUNOFF CONTROL)
 - 6.) 606 - SUBSURFACE DRAIN, 6"Ø = 100 LF (ROOF RUNOFF CONTROL)
 - 7.) 620 - UNDERGROUND OUTLET, 6"Ø = 850 LF (ROOF RUNOFF OUTLET)
 - 8.) 606 - SUBSURFACE DRAIN, 4"Ø = 264 LF (PVT PERIMETER TILE)
 - 9.) 620 - UNDERGROUND OUTLET, 4"Ø = 890 LF (PERIMETER TILE OUTLET)
 - 10.) 500 - OBSTRUCTION REMOVAL, CONCRETE SLAB = 10,500 SF (SLAB LOCATED ON PROPOSED BARN SITE)

PROPOSED 890 LF, 4" Ø OUTLET TILE TO CONNECT TO EXISTING TILE OR DAYLIGHT ABOVE GROUND. LOCATE OUTLET PRIOR TO CONSTRUCTION

PROPOSED 900 LF, 6" Ø OUTLET TILE TO CONNECT TO EXISTING TILE OR DAYLIGHT ABOVE GROUND. LOCATE OUTLET PRIOR TO CONSTRUCTION

PROPOSED CONFINEMENT BARN (76' x 185') w/ 12" DEEP CONCRETE PVT (94' x 40') BELOW SLATTED BARN FLOOR AND A BEDDED PACK AREA (100' x 75')

PROPOSED 100 LF, ROCK TRENCH WITH 6"Ø DRAIN TILE SLOPED @ 1.0% TO CENTER OF BARN. CONNECT TO UNDERGROUND OULET

PROPOSED HIGH POINT 4" Ø PERIMETER DRAIN TILE PLACED AROUND THE PVT FOOTING, SLOPE TILE @ 0.1% TO NE CORNER OF PVT

PROPOSED 20' UNCOVERED REINFORCED CONCRETE ALLEY

TO NEAREST WELL 233'

TO ROW 306'

BENCHMARK IS THE TOP OF CAP OF EXISTING WELL, ELEV. 1265.98

TO NEAREST WATER SOURCE 1570'

TO NEAREST RESIDENCE 2852'

ELEVATIONS ARE FROM AVAILABLE LIDAR DATA AND ARE BASED ON NAVD88 DATUM. GPS SURVEY SHOTS ON SITE VERIFIED ELEVATIONS. BENCHMARK IS THE TOP OF CAP OF EXISTING WELL, ELEVATION 1265.98

CONTRACTOR IS RESPONSIBLE FOR CALLING IOWA ONE CALL 1-800-292-8989 AT LEAST 48 HOURS PRIOR TO ANY EXCAVATION WORK.

THIS IS AN NRCS EQP FUNDED PROJECT. OWNER AND CONTRACTOR SHALL NOTIFY ENGINEER PRIOR TO ANY WORK TO ENSURE CONSTRUCTION COMPLIANCE WITH EQP REQUIREMENTS. FAILURE TO NOTIFY ENGINEER MAY RESULT IN LOSS OF EQP FUNDS.

****IF ANY CULTURAL RESOURCE OR EVIDENCE THEREOF IS IDENTIFIED ON SITE DURING CONSTRUCTION, THE CONTRACTOR SHALL STOP WORK IMMEDIATELY AND THE OWNER WILL NOTIFY THE NRCS ARCHEOLOGIST.****

*****ISSUED FOR BID*****
NOT FOR CONSTRUCTION

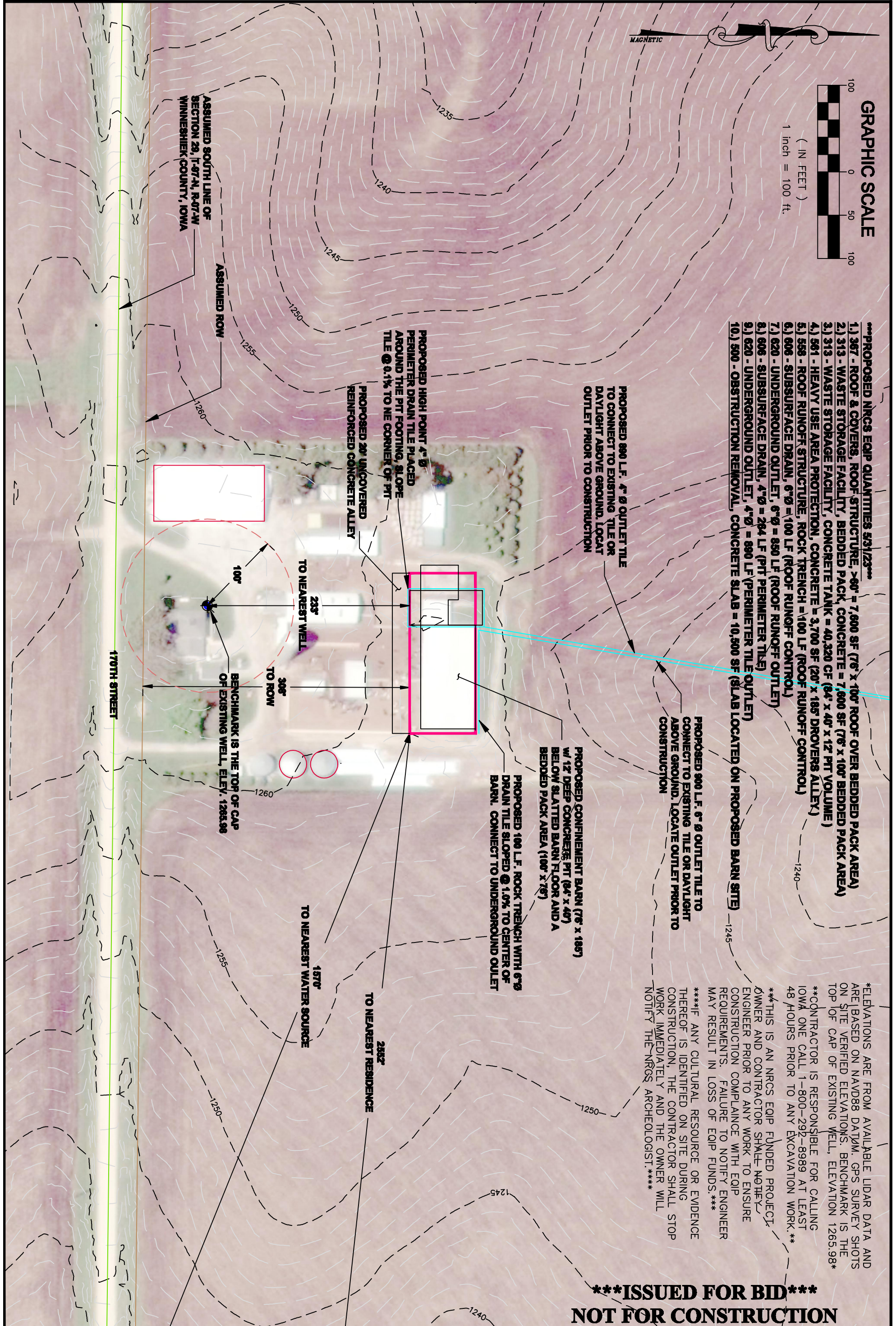

ProAg Engineering, Inc.
77402 U.S. Highway 71, P.O. Box 181
Jackson, MN 56143
(507) 849-7200

AJ & KATIE HAGEMAN
PROPOSED CATTLE CONFINEMENT BARN
SE 1/4, SECTION 29, T-97-N, R-07-W
WINNESHIK COUNTY, IOWA

Date	5/31/23	Checked By	JDS	Project No.	22-058
Drawn	TMW				

SHEET
2/7

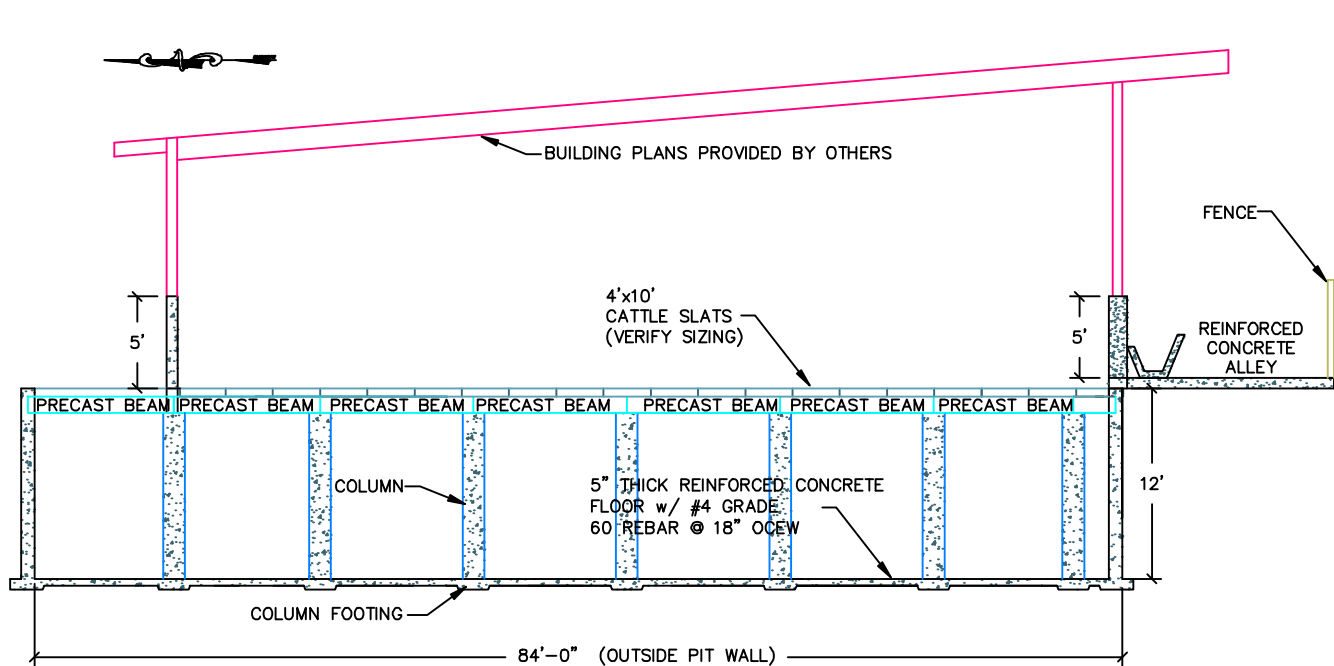

PIT CROSS SECTION (A-A)
(NOT TO SCALE)

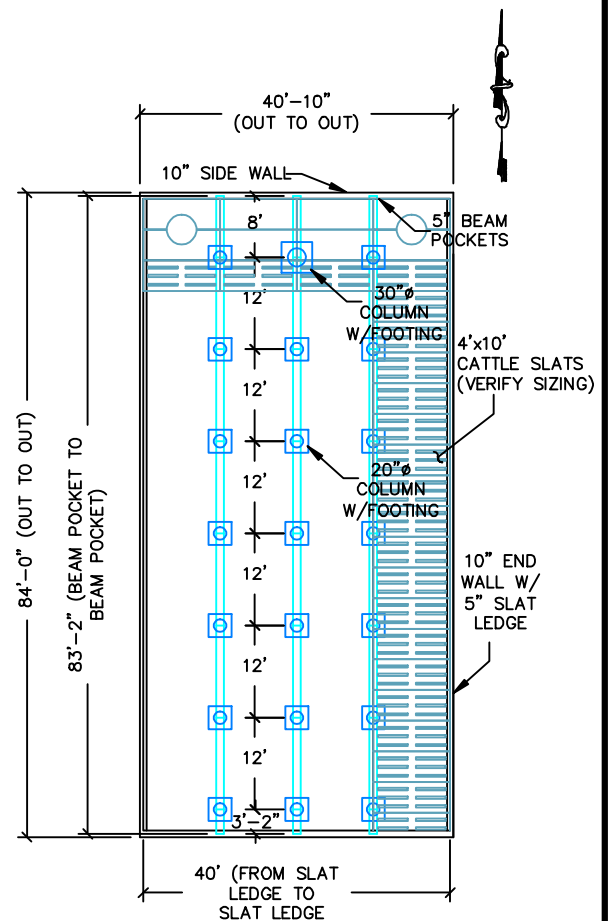

PIT PLAN
(OUTSIDE DIMENSIONS
76'-0" x 40'-10" x 12' PIT
(NOT TO SCALE)

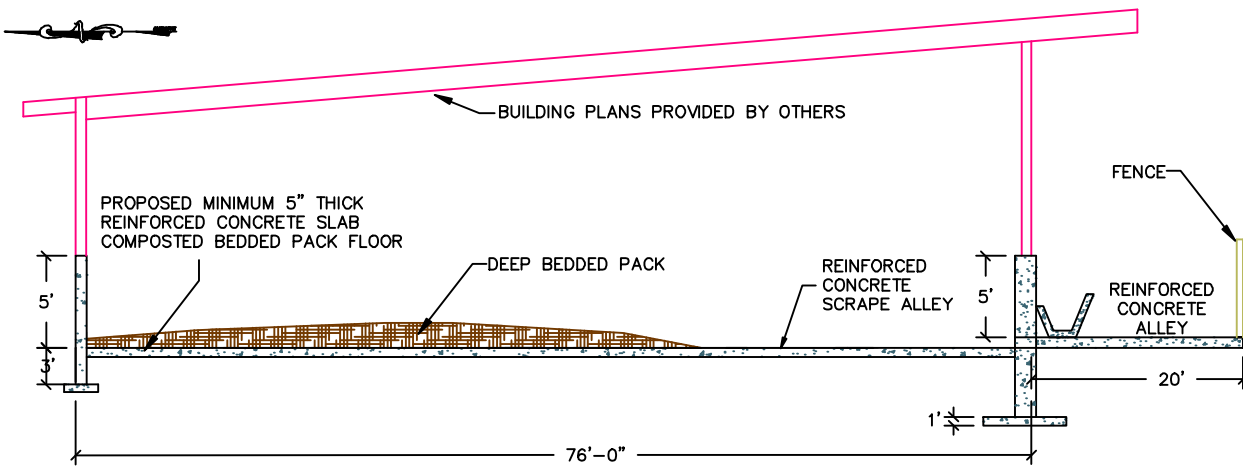

BED PACK CROSS SECTION (B-B)
(NOT TO SCALE)

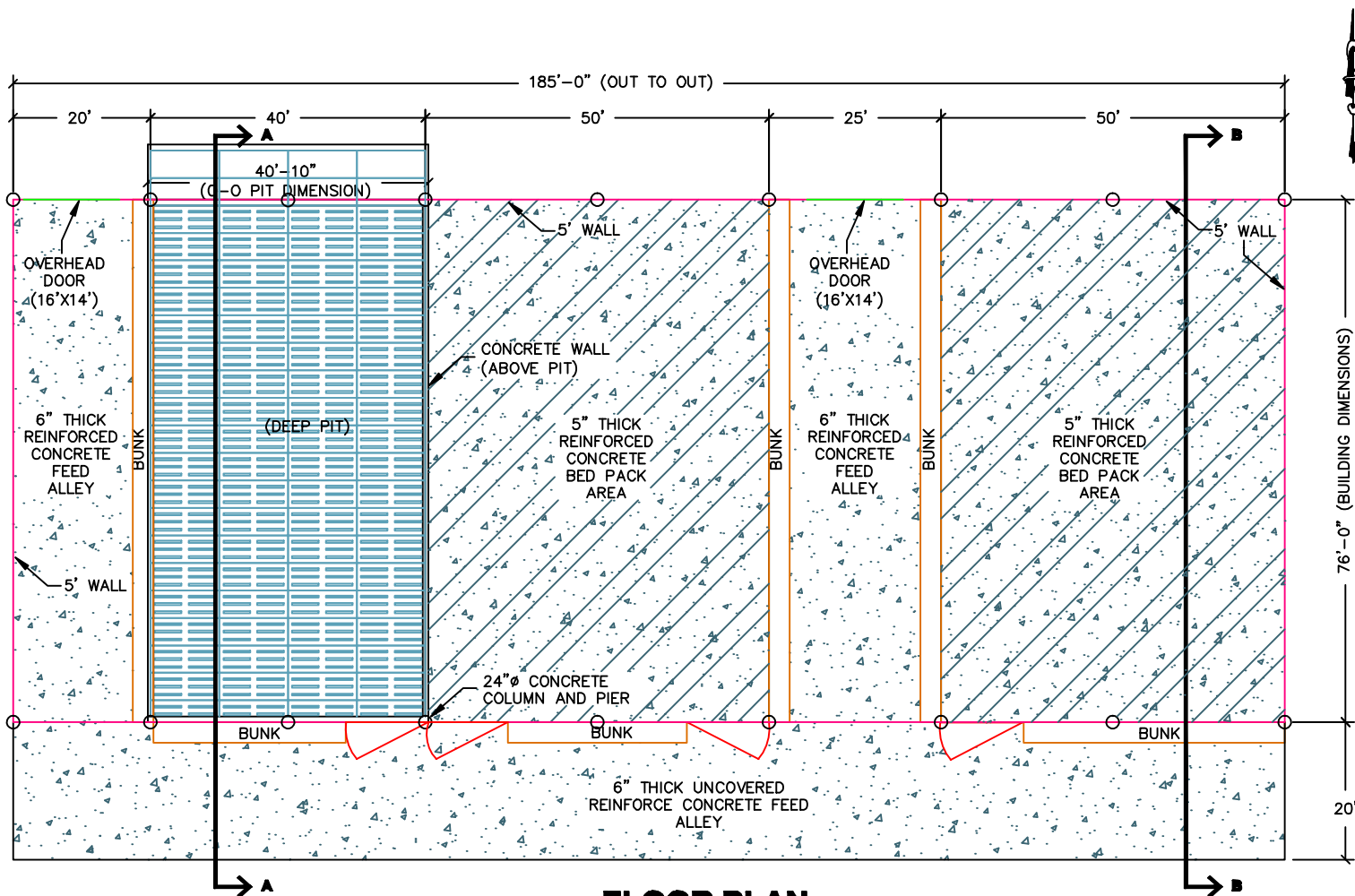

FLOOR PLAN
(OUTSIDE DIMENSIONS 76'-0" x 185'-0")
(NOT TO SCALE)

*****ISSUED FOR BID*****
NOT FOR CONSTRUCTION

***IMPORTANT NOTE - PRECAST DIMENSIONS CHANGE BETWEEN SUPPLIERS. PRECAST DIMENSIONS MUST BE VERIFIED WITH THE OWNER PRIOR TO CONSTRUCTION.**

**SIDE WALL
(NOT TO SCALE)**

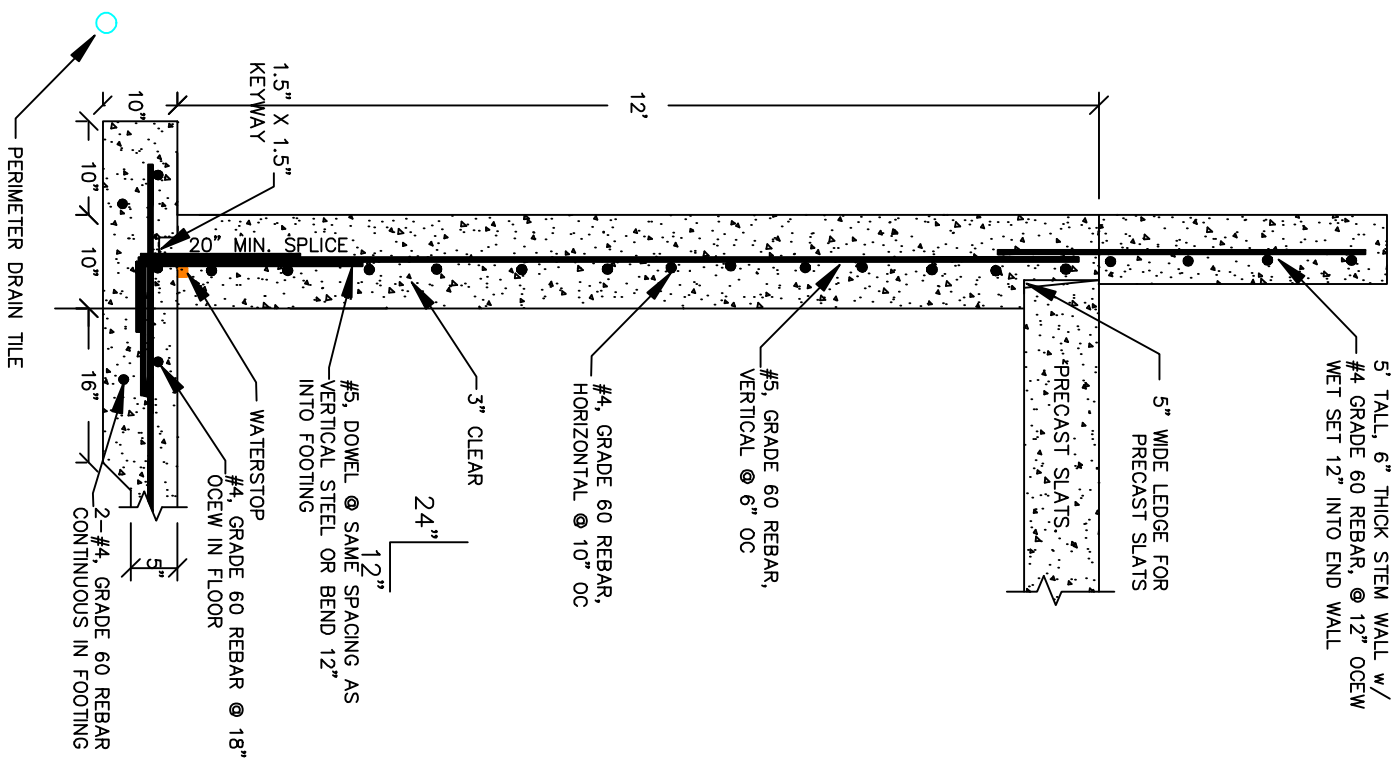

**END WALL BRACING & BEAM POCKET
(NOT TO SCALE)**

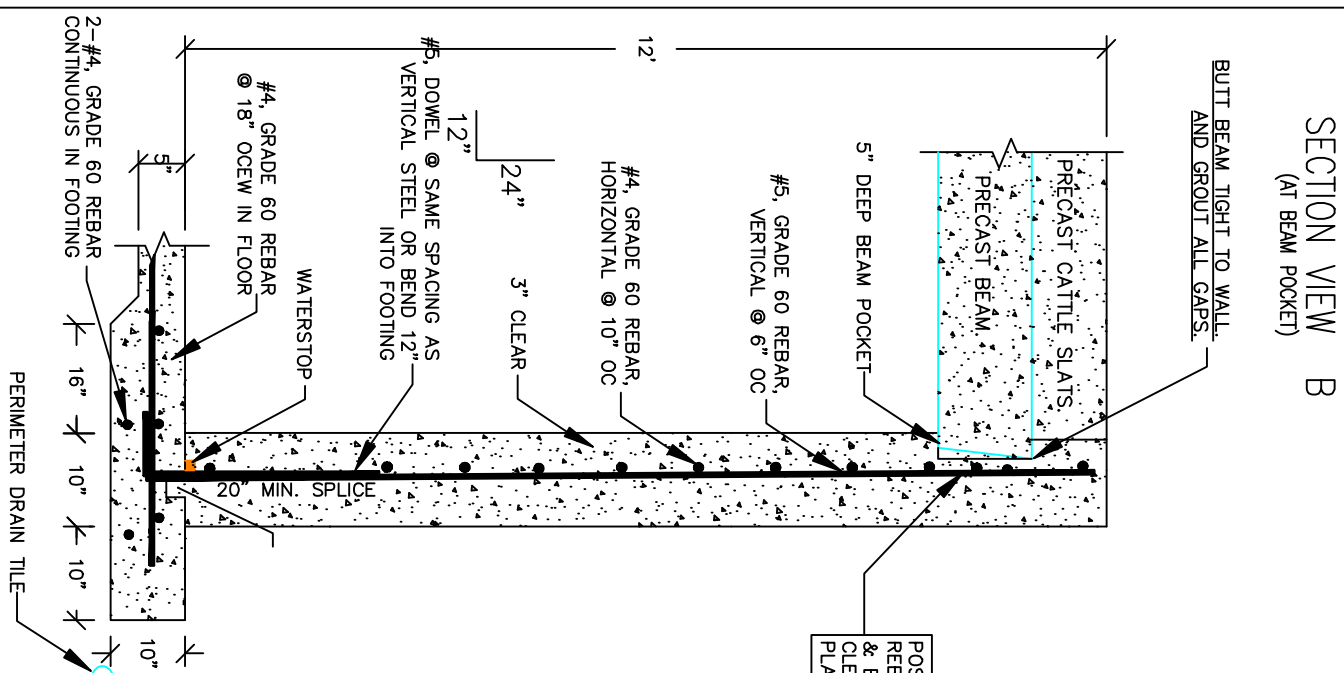

TOP VIEW

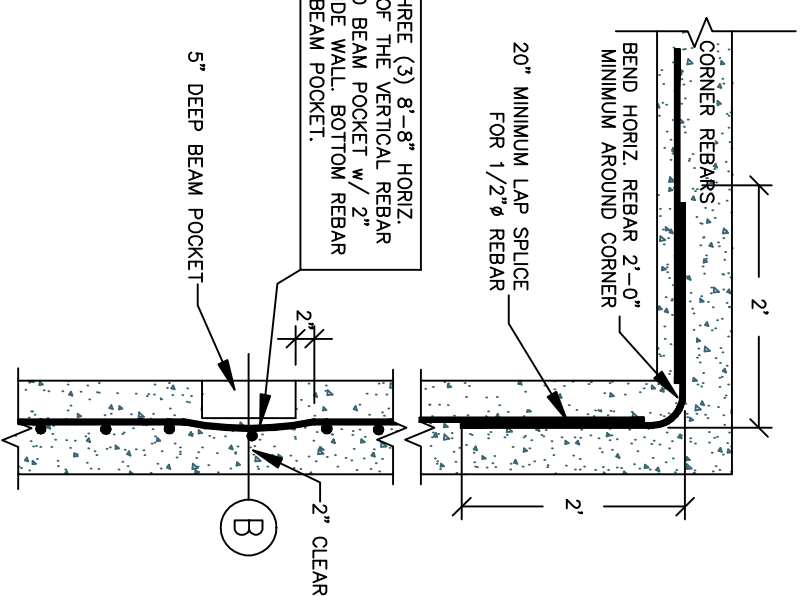

**COLUMN DETAIL
(NOT TO SCALE)**

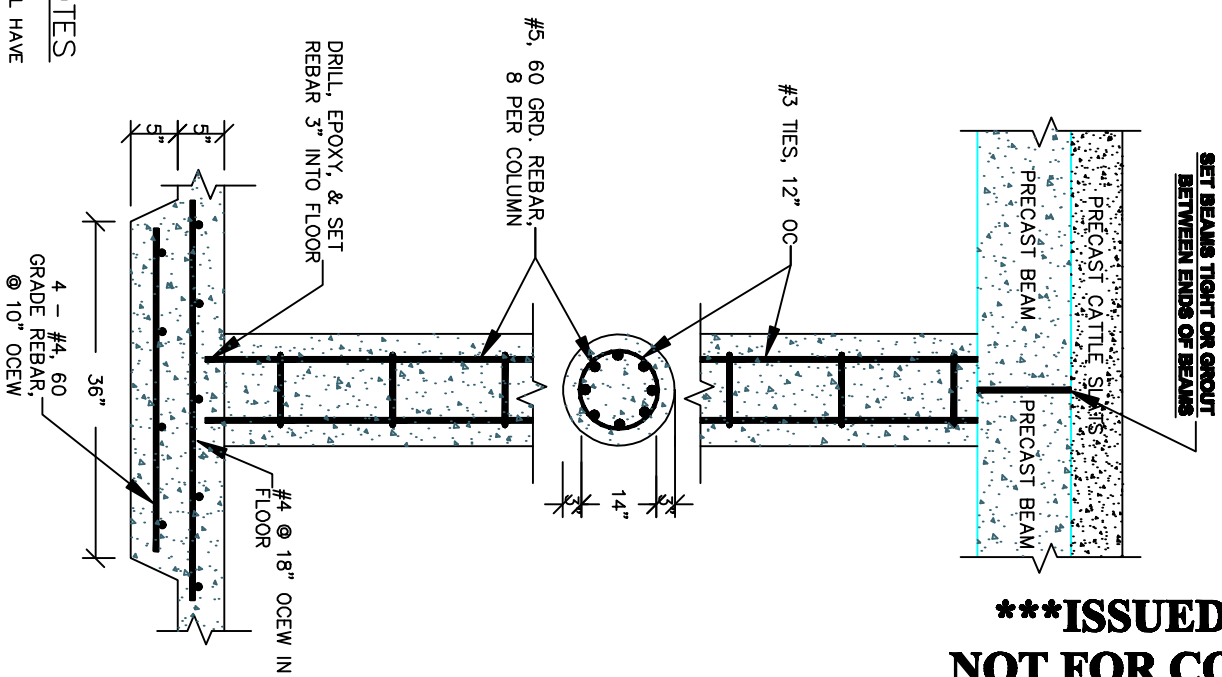

SLAT LEDGES & STEM WALL CONCRETE NOTES

- 1.) ANY SLAB ON GRADE WHICH WILL HAVE A VERTICAL WALL ON TOP SHALL HAVE A KEYWAY AND WATERSTOP AT SLAB/WALL INTERFACE.
- 2.) WATERSTOP TO BE BENTONITE ROLL OR RIBBED PVC @ CONTRACTOR'S OPTION.
- 3.) SLAT LEDGES MUST BE 5" WIDE x 6 1/2" HIGH.
- 4.) 10" OUTSIDE WALLS. THE 5" WIDE x 6 1/2" LEDGE ON INSIDE SIDE OF 10" WALL MUST BE FORMED AND POURED WITH WALL.
- 5.) A CONSTRUCTION JOINT IS PERMITTED BETWEEN THE PIT WALL AND STEM WALL, BUT THE CONSTRUCTION JOINT MUST BE EQUAL OR HIGHER THAN THE TOP OF THE PRE-CAST SLATS.

*****ISSUED FOR BID***
NOT FOR CONSTRUCTION**

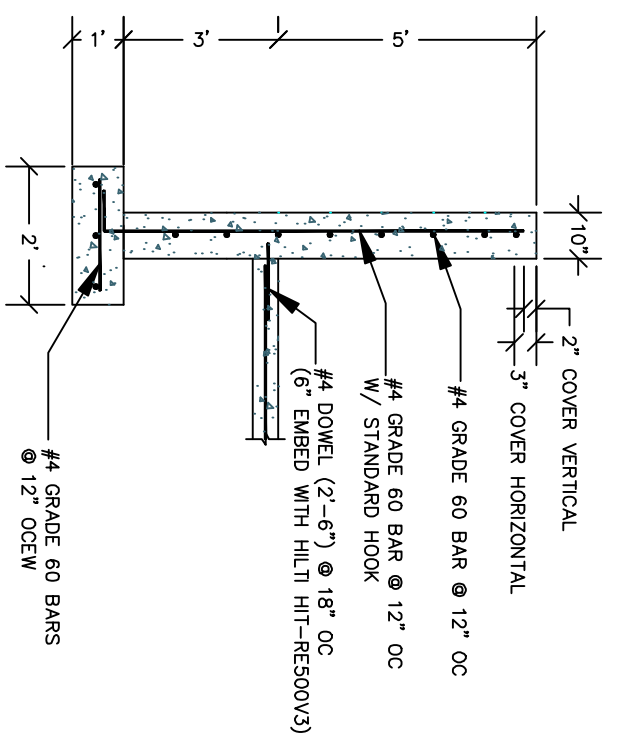

PERIMETER WALL
(NOT TO SCALE)

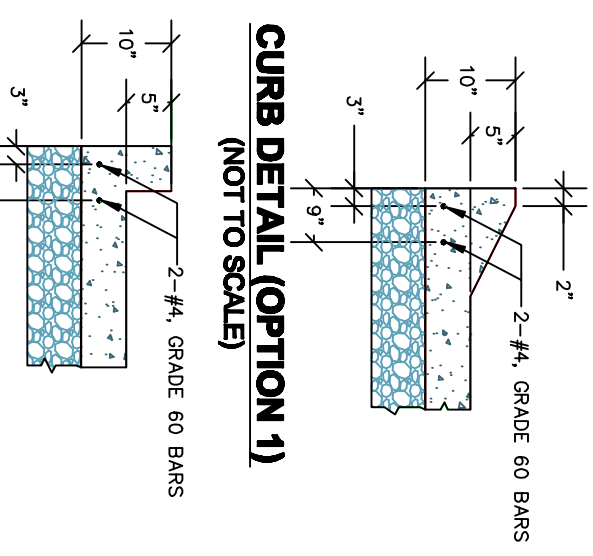

CURB DETAIL (OPTION 1)
(NOT TO SCALE)

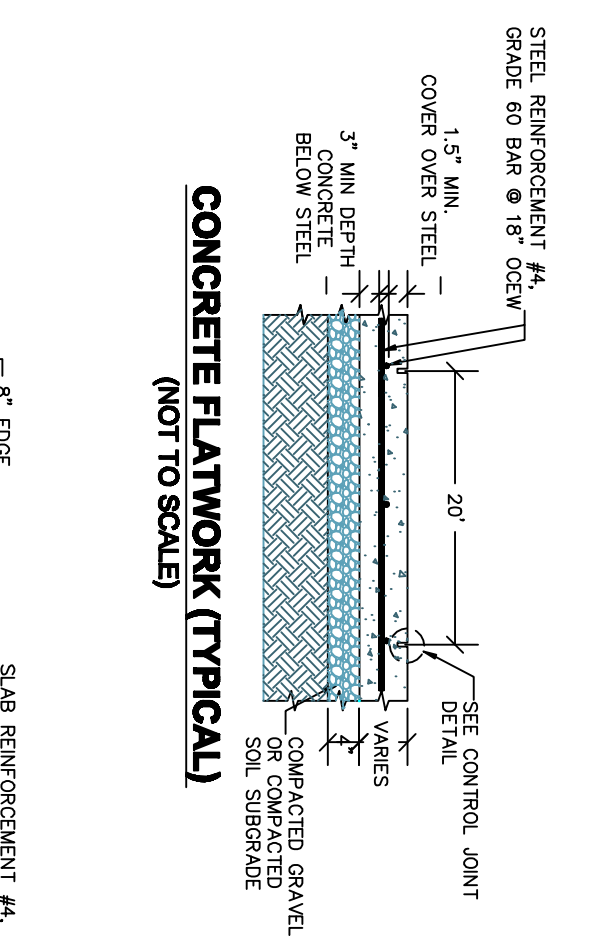

CONCRETE FLATWORK (TYPICAL)
(NOT TO SCALE)

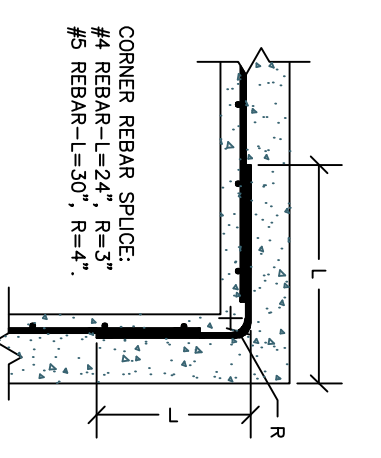

CORNER REBAR
(NOT TO SCALE)

*****ISSUED FOR BID*****
NOT FOR CONSTRUCTION

Date	5/31/23	Checked By	JDS	Project No.	22-058
Drawn	TMW				

NOTE
IF CURB IS POURED IN A SEPARATE POUR FROM FLATWORK, THEN STUB BARS ARE TO BE PLACED @ 18" OC

CURB DETAIL (OPTION 2)
(NOT TO SCALE)

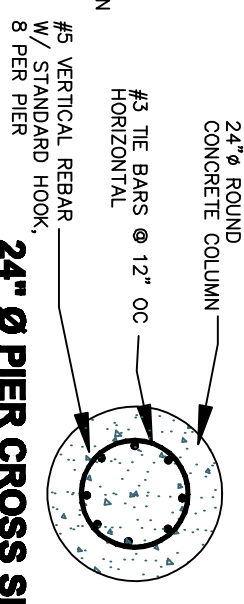

24" Ø PIER CROSS SECTION
(NOT TO SCALE)

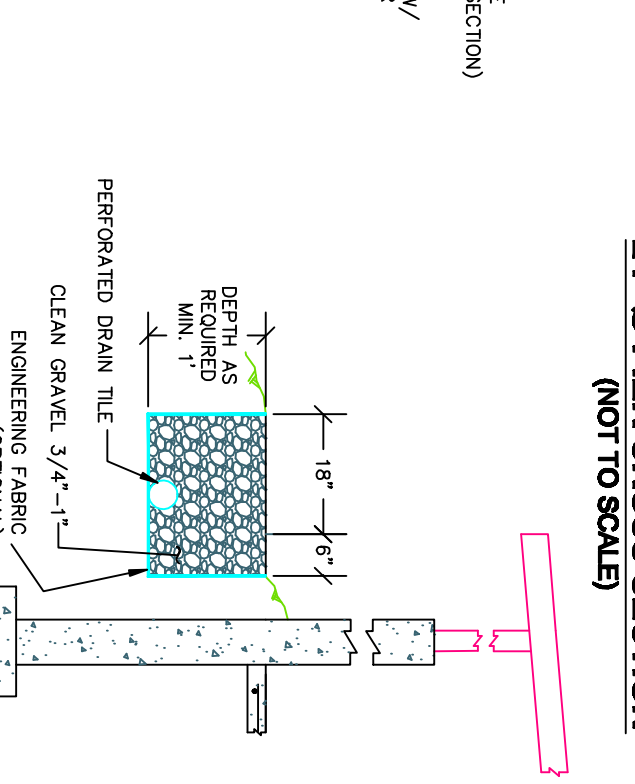

PIER CROSS SECTION
(24" Ø COLUMN)
(NOT TO SCALE)

THICKENED EDGE CONCRETE FLATWORK
(NOT TO SCALE)

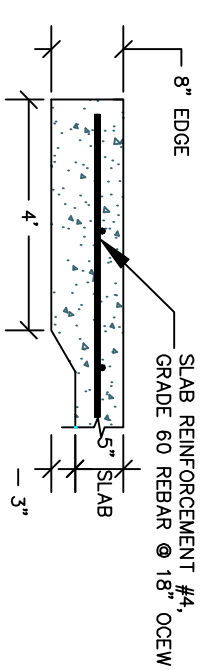

CONSTRUCTION JOINTS

ROUTER OUT CRACK WITH "CRACK CHASER" CONCRETE SAW. BLOW OUT CRACK WITH COMPRESSED AIR. FILL WITH BITUMINOUS SEALANT.

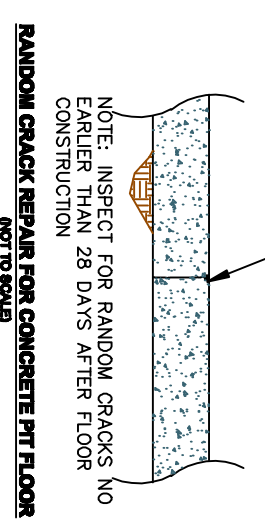

RANDOM CRACK REPAIR FOR CONCRETE PT FLOOR
(NOT TO SCALE)

NOTE: INSPECT FOR RANDOM CRACKS NO EARLIER THAN 28 DAYS AFTER FLOOR CONSTRUCTION

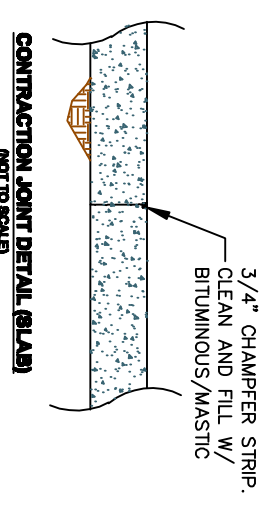

CONSTRUCTION JOINT DETAIL (SLAB)
(NOT TO SCALE)

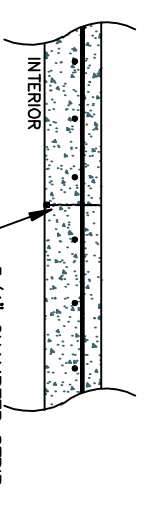

CONSTRUCTION JOINT DETAIL (WALL)
(NOT TO SCALE)

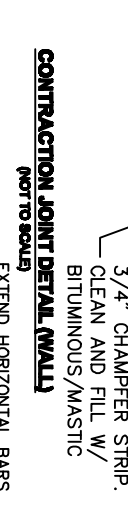

CONSTRUCTION JOINT DETAIL (SLAB)
(NOT TO SCALE)

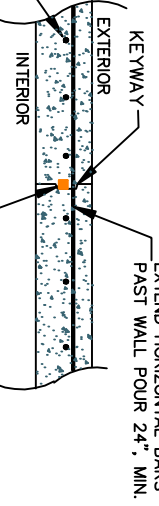

CONSTRUCTION JOINT DETAIL (WALL)
(NOT TO SCALE)

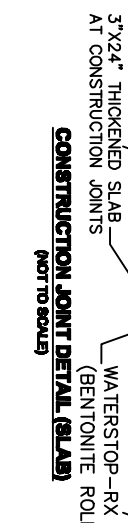

ROOF RUNOFF COLLECTION TILE
(NOT TO SCALE)

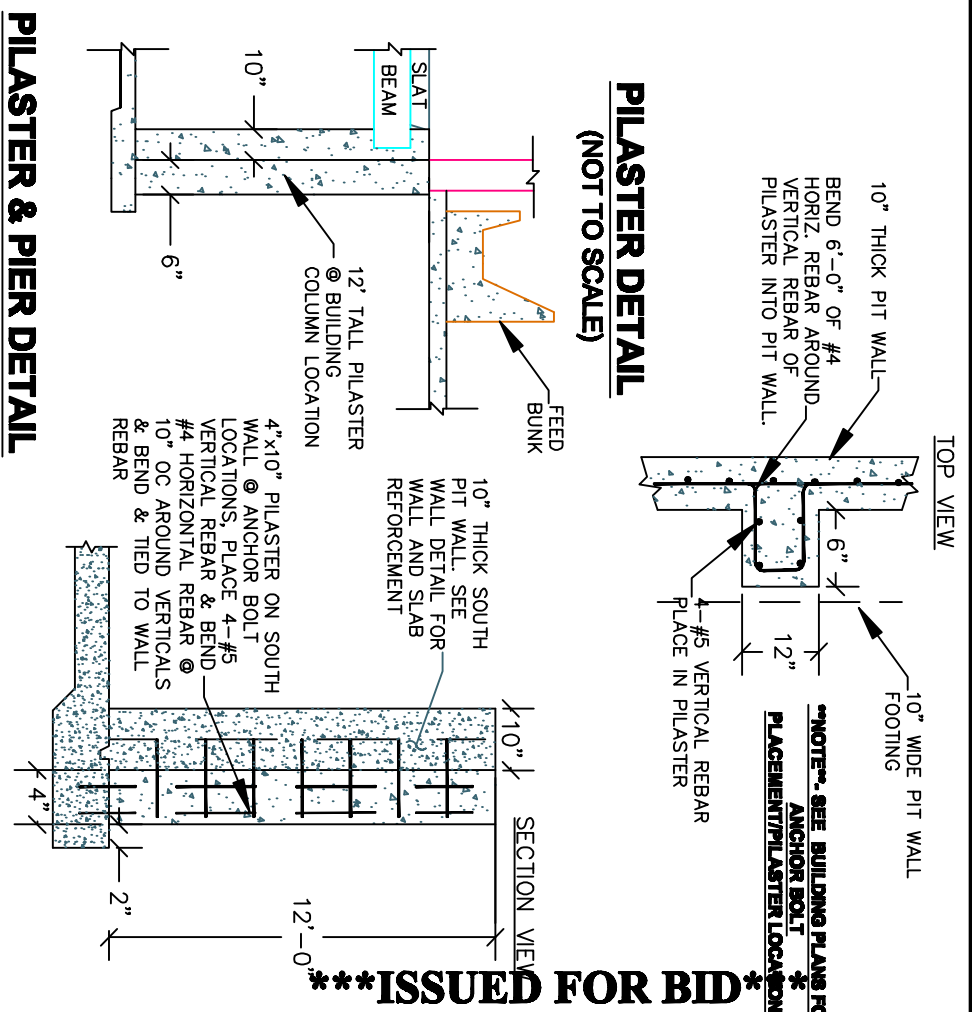
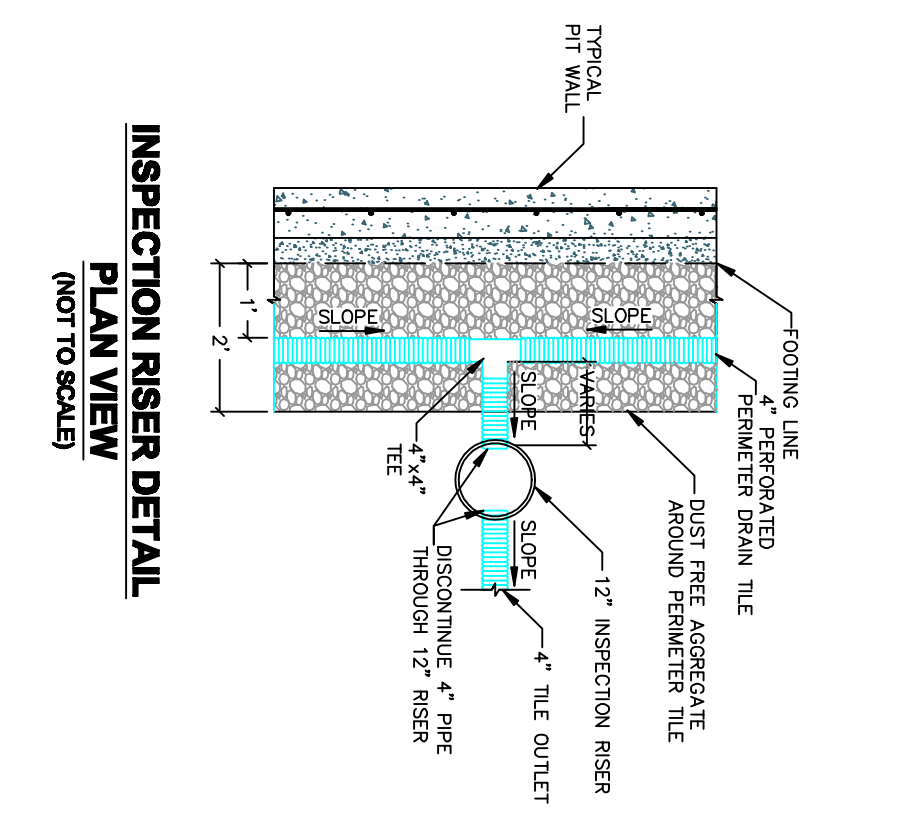
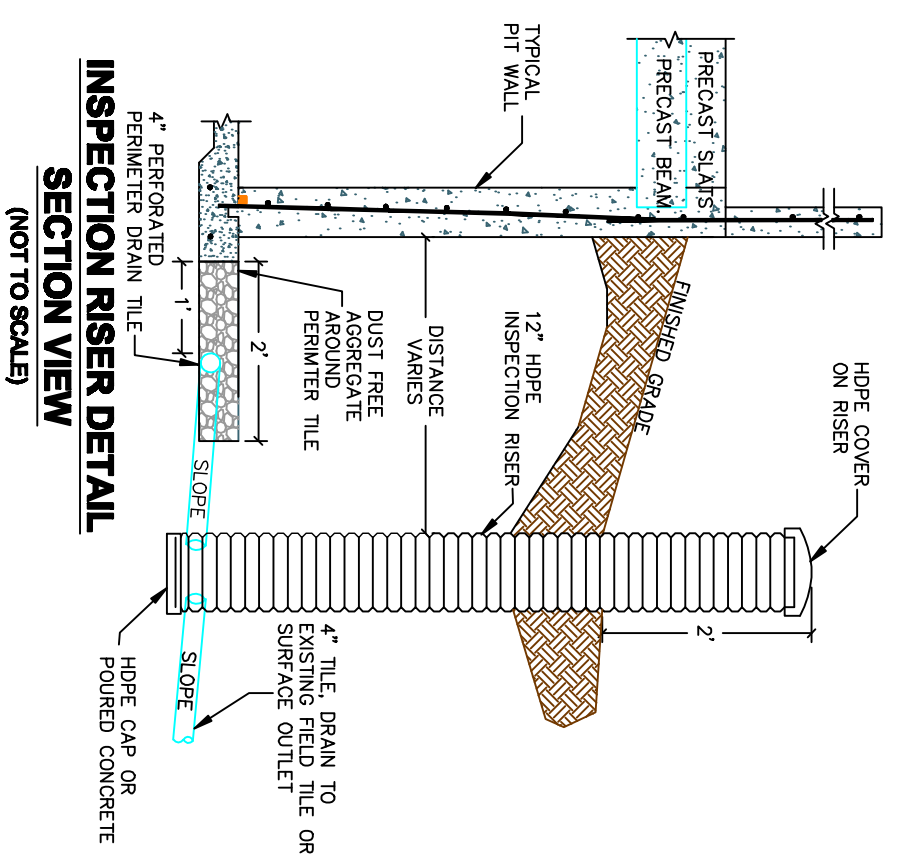

*****ISSUED FOR BID***
NOT FOR CONSTRUCTION**

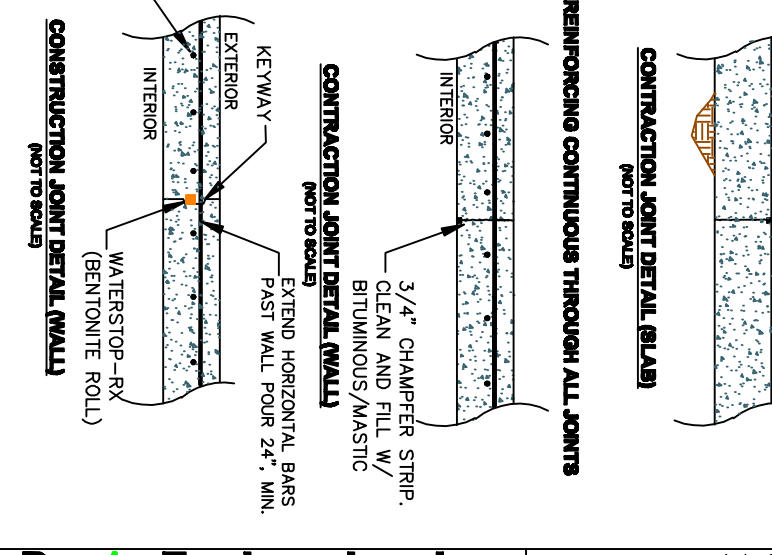
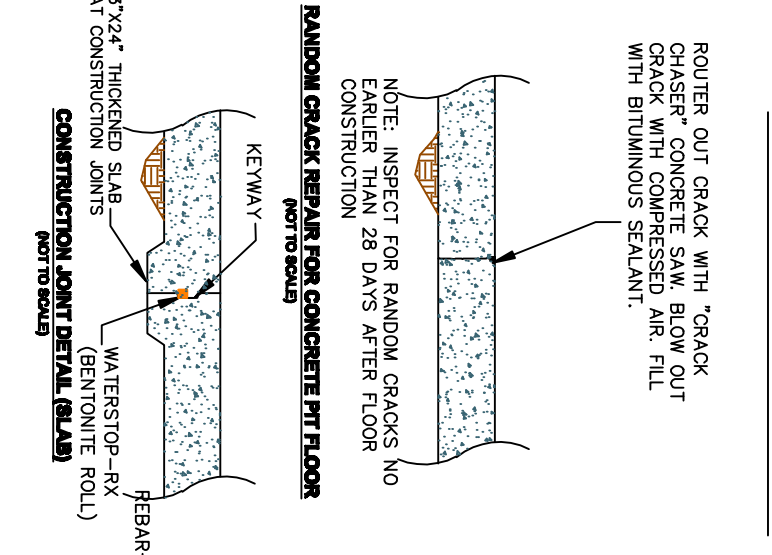
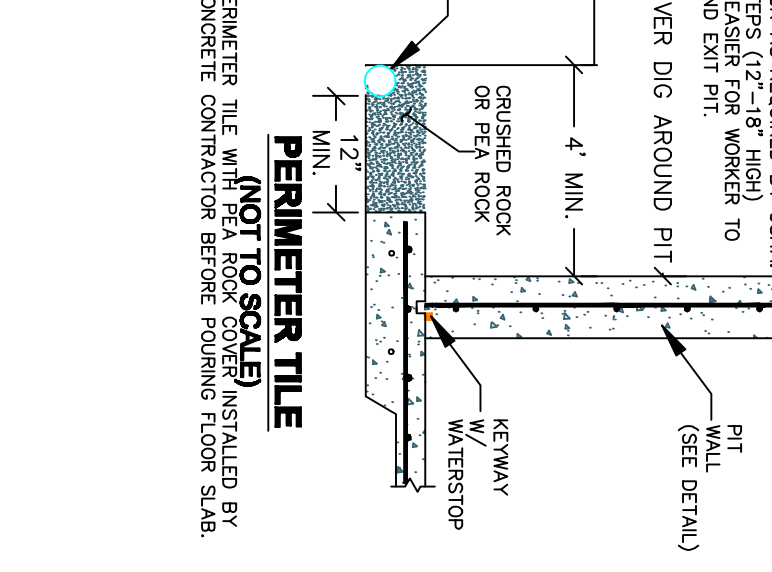
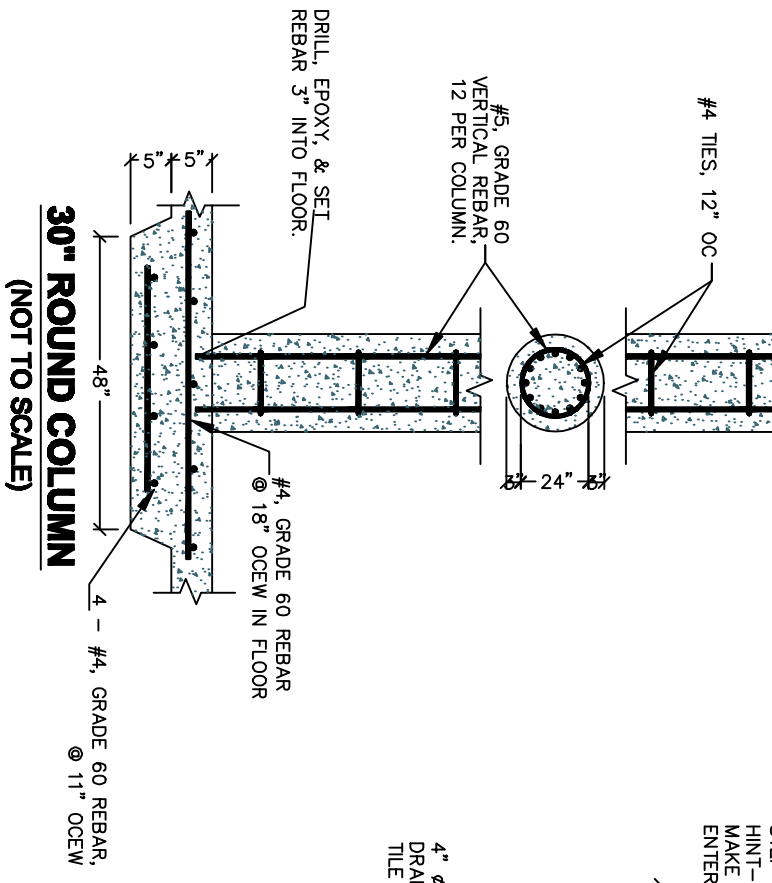
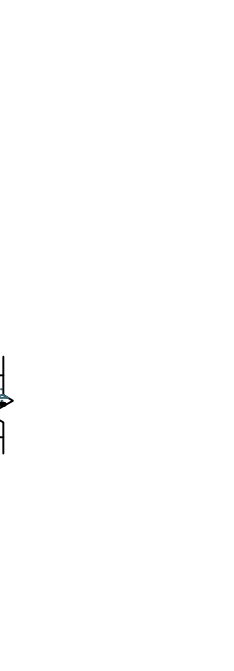
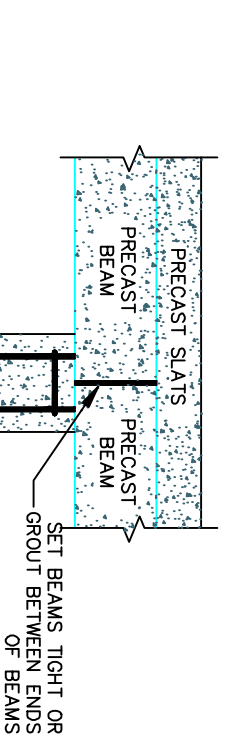

CONCRETE & STRUCTURAL NOTES:

- A. GENERAL**
- NOTES AND DETAILS ON THE STRUCTURAL DRAWINGS TAKE PRECEDENCE OVER THESE STRUCTURAL NOTES.
 - THE CONTRACTOR SHALL VERIFY ALL DIMENSIONS, ELEVATIONS, AND SITE CONDITIONS PRIOR TO STARTING WORK. THE ENGINEER SHALL BE NOTIFIED OF ANY DISCREPANCIES.
 - IN NO CASE SHALL DIMENSIONS BE SCALED FROM PLANS, SECTIONS, OR DETAILS ON THE STRUCTURAL DRAWINGS.
 - DESIGN CHANGES MUST BE APPROVED IN WRITING BY BOTH THE OWNER AND ENGINEER BEFORE PROCEEDING WITH THE WORK. SOME DESIGN CHANGES MAY ALSO REQUIRE IDNR, COUNTY AND/OR NRCS APPROVAL.
 - ANCHOR BOLTS SHALL BE SET AS SPECIFIED BY BUILDING CONTRACTOR.
 - ALL MATERIALS AND WORKMANSHIP SHALL CONFORM TO THE REQUIREMENTS OF THE FOLLOWING CODES:
 - UNIFORM BUILDING CODE (UBC)
 - IOWA STATE BUILDING CODE
 - AMERICAN CONCRETE INSTITUTE (ACI)
 - CONCRETE REINFORCING STEEL INSTITUTE (CRSI) MANUAL OF STANDARD PRACTICE
- B. DRAIN TILE**
- BEFORE ANY PIT CONSTRUCTION, TRENCH AND INSTALL DRAIN AROUND THE PROPOSED PIT. THE DRAIN TILE FLOW LINE MUST BE A MINIMUM OF 12" BELOW THE TOP.
 - THE DRAIN TILE SHALL BE HEAVY DUTY PERFORATED POLYETHYLENE TUBING, 4"Ø TILE WITH PEA ROCK COVER OR 4"Ø TILE W/ FABRIC SLEEVE AND SAND/GRAVEL COVER.
 - CONNECT THE DRAIN TILE TO AN EXISTING FARM TILE IF AVAILABLE; DISCHARGE TO SURFACE DRAINAGE; OR DRAIN TO A SUMP AND PUMP TO SURFACE.
- C. TEMPORARY BRACING AND BACKFILL**
- PROVIDE TEMPORARY LATERAL SUPPORT FOR ALL WALLS WHERE GRADE VARIES ON THE TWO SIDES UNTIL THE PERMANENT STRUCTURAL SUPPORT SYSTEM IS IN PLACE.
 - BACKFILL ONLY AFTER THE FLOOR SLATS OR SOLID FLOOR HAS BEEN INSTALLED.
 - DO NOT BACKFILL AGAINST WALL UNTIL SLATS ARE INSTALLED AND GROUDED.
 - CONCRETE IN ALL WALLS SHALL BE ALLOWED TO CURE FOR A MINIMUM OF 7 DAYS BEFORE BACKFILL IS PLACED AGAINST WALLS. EXERCISE CAUTION WHEN BACKFILLING TO BRING UP THE LEVEL UNIFORMLY ON ALL SIDES OF TANKS AND PITS.
- D. FOOTINGS, FOUNDATIONS & SUBGRADE**
- SOIL BEARING DESIGN VALUE:.....3000 PSF ON VIRGIN SOIL OR COMPACTED FILL FOR FOOTINGS.
 - PROTECT FOUNDATION EXCAVATIONS FROM FROST. DO NOT PLACE CONCRETE ON FROZEN GROUND.
 - EXISTING DISTURBED SUBGRADE SHALL BE RECOMPACTED TO 95 % OF STANDARD PROCTOR DENSITY.
 - ALL FILL UNDER FOOTINGS AND SLAB SHALL BE COMPACTED TO A DRY DENSITY OF AT LEAST 95 % OF MAXIMUM DRY DENSITY AS DETERMINED BY AASHTO T-180.
 - SAND FILL AS REQUIRED FOR LEVELING SUBGRADES SHALL BE PROVIDED AT ALL SLAB ON GRADE AREAS.
- E. REINFORCED CONCRETE**
- ALL CONCRETE AND REINFORCING WORK SHALL CONFORM TO AMERICAN CONCRETE INSTITUTE'S" STANDARD BUILDING CODE REQUIREMENTS FOR REINFORCED CONCRETE", (ACI 318-05)
 - CONCRETE WORK SHALL CONFORM TO ALL THE REQUIREMENTS OF ACI 301.
 - CONCRETE SHALL HAVE A MINIMUM 28-DAY COMPRESSIVE STRENGTH OF f'c=4000 PSI FLOOR, 4000 PSI WALLS
 - WATER CEMENT RATIO SHALL BE 0.45 MAXIMUM
 - CEMENT SHALL CONFORM TO ASTM C150, TYPE 1.
 - COARSE AGGREGATE SHALL BE 1".
 - READY-MIX CONCRETE SHALL BE MIXED & DELIVERED IN ACCORDANCE WITH ASTM C94.
 - SLUMP SHALL BE MAXIMUM OF 5"
 - AIR CONTENT SHALL BE 5% TO 7%
 - CONCRETE TO BE CURED WITH SPOBORN CURE AND SEAL OR EQUAL.
 - ADMITTRES MAY BE USED WITH PRIOR APPROVAL OF THE ENGINEER FOR THE PURPOSE OF INCREASING THE WORKABILITY BUT NOT TO REDUCE THE SPECIFIED MINIMUM CEMENT CONTENT. CALCIUM CHLORIDE SHALL NOT BE USED.
 - FLOORS SHALL BE 5" THK. WITH #4, GRADE 60 REBAR @ 18" O.C.E.W.
 - IF CONSTRUCTION JOINTS NECESSARY, COORDINATE LOCATION WITH ENGINEER.
 - CONSTRUCTION JOINTS ARE NOT PERMITTED IN THE END WALLS OR WITHIN 3 FT. OF A PUMP-OUT. THE PUMP-OUT FLOOR AND FOOTING MUST BE FORMED AND Poured WITH THE PIT FLOOR. THE PUMP-OUT WALLS MUST BE FORMED AND Poured WITH THE PIT WALLS.
 - REINFORCING STEEL SHALL BE PLACED IN THE CENTER OF CONCRETE PLACEMENT UNLESS NOTED OTHERWISE. STEEL MUST BE SUPPORTED WITH APPROPRIATE CHAIRS OR CONCRETE BLOCKS.
- F. STEEL**
- F₁Y = GRADE 60 (60,000 PSI) DEFORMED STEEL.
 - REINFORCING SHALL BE CONTINUOUS AND LAP A MINIMUM OF 40 BAR DIAMETER UNLESS NOTED OTHERWISE. WELDED WIRE FABRIC SHALL BE LAPPED A MINIMUM OF EIGHT INCHES.
 - MINIMUM BENDING RADIUS SHALL BE 6 BAR DIAMETERS.
 - MINIMUM BEND AROUND CORNERS FOR #4 BARS - 24", FOR #5 BARS - 30"
 - ALL CONCRETE IS REINFORCED UNLESS SPECIFICALLY CALLED OUT AS "NOT REINFORCED". REINFORCE ALL CONCRETE NOT OTHERWISE SHOWN WITH THE SAME STEEL AS IN SIMILAR SECTIONS OR AREAS.
 - THE FOLLOWING MINIMUM CONCRETE COVER SHALL BE PROVIDED FOR REINFORCEMENT UNLESS OTHERWISE NOTED:

WHERE CAST AGAINST EARTH	3 INCHES
WALLS AND SLABS (EXPOSED TO EARTH OR WEATHER).....	2 INCHES
OTHER.....	2 INCHES
- G. TOLERANCES & QUALITY CONTROL**
- COLUMN FINISH ELEVATIONS SHALL BE + OR - 1/4" FROM DESIGN ELEVATION.
 - WALL ALIGNMENT (HORIZONTAL) SHALL DEVIATE NO MORE THAN 1/4" IN 10 FT. NO MORE THAN 3/4" OVER THE FULL LENGTH OF WALL.
 - WALL BEARING LEDGE ELEVATIONS SHALL BE + OR - 1/4"FROM DESIGN ELEVATION IN 10 FT. AND NO MORE THAN 1/2" OVER THE FULL LENGTH OF WALL.
 - OVERALL FOUNDATION LENGTH & WIDTH DIMENSIONS AND DIAGONAL DIMENSIONS SHOULD BE WITHIN 1/2" OF PLAN DIMENSIONS.
 - HONEYCOMB AND SHRINKAGE CRACKS WIDER THAN THE THICKNESS OF A PLASTIC CREDIT CARD SHALL BE FILLED WITHIN 48 HOURS WITH CEMENT GROUT SLURRY MOPPED INTO THE CRACKS. DO THE GROUTING OF FLOOR CRACKS BEFORE DIRT AND EQUIPMENT ARE BROUGHT ON THE FLOOR.
- H. ELECTRICAL GROUND**
- INSTALL REINFORCING BARS AS PER ELECTRICAL CODE GROUND AT A MINIMUM LOCATIONS AS PER ELECTRIC CODE NOTIFY THE LOCAL ELECTRICAL INSPECTOR FOR INSPECTION PRIOR TO PLACING CONCRETE.
- I. COLD WEATHER CONCRETING**
- WHEN, FOR MORE THAN 3 CONSECUTIVE DAYS, THE MEAN DAILY TEMPERATURE DROPS BELOW 40° F., THE CONTRACTOR SHALL PLACE AND PROTECT THE CONCRETE IN ACCORDANCE WITH ACI 306.
- J. HOT WEATHER CONCRETING**
- WHEN IT IS LIKELY THAT TEMPERATURE BETWEEN 75° F AND 100° F WILL BE APPROACHED OR EXCEEDED; THAT LOW RELATIVE HUMIDITY IS PRESENT; OR WIND VELOCITY WILL EXCEED 10 MPH, THE CONTRACTOR SHALL PLACE & PROTECT THE CONCRETE IN ACCORDANCE WITH CHAPTERS 4 & 5 OF ACI 305.
- K. WATERSTOPS & SEALANTS**
- WATERSTOP TO BE RIBBED PVC, OR BENTONITE ROLL, AT CONTRACTOR'S OPTION.
 - 3/8"x3/4" BENTONITE/BUTYL RUBBER EQUAL TO WATERSTOP-RX BY AMERICAN COLLIED COMPANY WATERSTOPS SHALL BE PLACED IN ALL CONSTRUCTION JOINTS ON THE FLOOR AND IN THE WALLS. LOCATION AND NUMBER OF CONSTRUCTION JOINTS ARE TO BE DETERMINED BY THE CONTRACTOR. WATERSTOPS SHALL BE SUITABLE FOR USE WITH MANUURE.
 - MAKE PVC WATERSTOP SPLICES WITH SPLICING IRON.
 - SEALANT TO BE ELASTOMETRIC POLYURETHANE OR BITUMINOUS ASPHALT BASED.

TABLE OF MATERIALS

SLATTED AREA			
ITEM	QUANTITY	UNIT	Notes
12" REINF. CONC. WALL W/ FTG	247	LF	SEE DETAIL
5" REINF. CONCRETE FLOOR	3,294	SF	SEE DETAIL
20" REINF. PIT COLUMN W/ FTG	20	EA	SEE DETAIL
30" REINF. PIT COLUMN W/ FTG	1	EA	SEE DETAIL
5' REINF. CONC. STEM WALL	41	LF	SEE PERIMETER WALL
PRECAST BEAM	249.5	LF	VERIFY PRECAST DIM.
PRECAST SLAT	76	EA	4"x10"
PRECAST PUMP-OUT SLAT	2	EA	W/ ACCESS
PRECAST SOLID SLAT	4	EA	4"x10"
PERIMETER TILE	264	LF	4"Ø PERFORATED
RUBBER MATS	3,294	SF	OVER CATTLE SLATS
PERIMETER TILE OUTLET	890	LF	4"Ø NONPERFORATED
INSPECTION RISER	1	EA	SEE DETAIL
BUNK W/ RAIL	104	LF	PRECAST
WATERER W/ RAIL	1	EA	90° CONCRETE
GATE	1	EA	12'

BEDDED AREA			
ITEM	QUANTITY	UNIT	Notes
5" REINF. CONC. FLOOR	7,600	SF	SEE DETAIL
5' PERIMETER WALL W/ FTG	176	LF	SEE DETAIL
5' REINF. CONC. STEM WALL	76	LF	SEE PERIMETER WALL
5' REINF. CONC. COLUMNS W/ FTG	5	EA	SEE DETAIL
BUNK W/ RAIL	140	LF	PRECAST
WATERER W/ RAIL	2	EA	90° CONCRETE
GATE	3	EA	12'

OTHER			
ITEM	QUANTITY	UNIT	Notes
6" REINF. CONC. FLOOR	7,120	SF	SEE DETAIL
5' PERIMETER WALL W/ FTG	76	LF	SEE DETAIL
5' REINF. CONC. COLUMNS W/ FTG	2	EA	SEE DETAIL
FENCE	185	LF	OWNER'S DISCRETION
ROCK TRENCH	100	LF	1" CLEAN ROCK
DRAIN TILE, 6"Ø	125	LF	6"Ø PERFORATED
PERIMETER TILE OUTLET	900	LF	6"Ø NONPERFORATED
OVERHEAD DOOR	2	EA	16'x14'

NOTE:
CONTRACTOR RESPONSIBLE FOR ALL FINAL QUANTITIES. ESTIMATED MATERIAL QUANTITIES ARE TO BE USED FOR BID PURPOSES ONLY. EXPECT MINOR CHANGES IN FINAL DESIGN.

*****ISSUED FOR BID***
NOT FOR CONSTRUCTION**

Date	5/31/23	Checked By	JDS	Project No.	22-058
Drawn	TMW				

AJ & KATIE HAGEMAN
PROPOSED CATTLE CONFINEMENT BARN
SE 1/4, SECTION 29, T-97-N, R-07-W
WINNESHIEK COUNTY, IOWA

ProAg Engineering, Inc.
77402 U.S. Highway 71, P.O. Box 181
Jackson, MN 56143
(507) 849-7200