



3/23/23

To: All Potential Respondents
From: Construction Procurement
Subject: RFQ 933200-01DOC FDCF Unit A Water Heater Replacement

Request for Quote

The State of Iowa is conducting a Request for Quote for a contractor to complete demo of an existing hot water tank and components and install a new heat exchanger and tank system at the Fort Dodge Correctional Facility in Building A. See Exhibit B for additional detail.

All work must be done on-site at the Fort Dodge Correctional Facility and all personnel must pass a background check. Information required for the background check includes full name, birthdate, state driver's license # or State id#, and social security number.

Construction is expected to start on 5/19/23 and be substantially complete by 8/18/23.

The Project is located at 1500 L St, Fort Dodge, IA 50501.

Please email your quote using the Exhibit A pricing form to construction.procurement@iowa.gov prior to 4/20/23 at 2:00 PM (CT).

All questions regarding this solicitation must be received by email by 2:00 PM (CT) ON 4/13/23.

A Pre-Bid Meeting will be held on 4/6/23 at 11:00 AM at the Fort Dodge Correctional Facility at 1500 L St, Fort Dodge, IA 50501.

Contract Terms and Conditions

This procurement will result in a Consensus 802 Agreement. By submitting a quote, respondent agrees to the contract terms and conditions available at

<https://das.iowa.gov/sites/default/files/procurement/pdf/ConsensusDoc802.pdf>

Performance Bond

Respondent must provide a Performance and Payment Bond in accordance with Section 10.8 of Consensus 802 Agreement.

Insurance Requirements

See sample Certificate of Insurance attached as Exhibit D for required limits, additional insured requirements and waiver of subrogation.

Attachments:

Exhibit A Pricing Form

Exhibit B Scope of Work

Exhibit C Facility Work Requirements

Exhibit D Certificate of Insurance

Exhibit E Allowance

Exhibit F Proposed Schedule

Exhibit A Pricing Form
DOC FDCF Unit A Water Heater Replacement
Fort Dodge Correctional Facility
Request for Quote RFQ933200-01

Due Thursday, 4/20/23 at 2:00 PM (CT)

Please submit this completed form with your Quote to:
Attention: Jeffrey Just
Iowa Department of Administrative Services - Central Procurement
construction.procurement@iowa.gov

This form is to be completed in ink or typewritten.
Only pricing on this form or an exact copy of this form will be accepted.
Pricing Form shall be signed by an officer of the firm with authority to bind Respondent to Contract.

Respondent acknowledges receipt of the following Addenda (if issued) which are part of the RFQ documents:

Addendum No. _____ Date _____

Addendum No. _____ Date _____

Freight Terms: FOB Destination, Freight Pre-Paid

The State reserves the right to reject any or all quotes without penalty and to waive minor deficiencies and informalities if, in the judgement of the State, it's best interests will be served.

Respondents must submit pricing for all scope of work items indicated per the attached Exhibit B. The State reserves the right to evaluate pricing. The State intends to make one Award for this project.

Lump Sum Price for DOC FDCF Unit A Water Heater Replacement

Base Bid: Water Heater Replacement. Include an allowance of \$15,000 for equipment controls (See Exhibit E).

(Labor and Material(s)) Total \$ _____

Alternate #1: Add Supply and Installation of an additional Heat Exchanger and Pump. Include an allowance of \$3,772.67 for the equipment controls (See Exhibit E).

(Labor and Material(s)) Total \$ _____

Please note all pricing is to be delivered price. That is why we are stating FOB Destination, Freight Pre-Paid.

Signature _____

Name (Print) _____

Title _____

Company _____

Address _____

City, St., Zip _____

Phone # _____ **Fax #** _____

E-mail _____

Exhibit B Scope of Work

DOC FDCF Unit A Water Heater Replacement
Fort Dodge Correctional Facility
Request for Quote RFQ933200-01
Due Thursday, 4/20/23 at 2:00 PM (CT)

SCOPE OF WORK

Drawing Sheets: All drawings sheets titled IA DAS – FDCF BUILDING A WATER HEATER REPLACEMENT dated 3/21/2023. Drawing Sheets List: G001, P000, P101, & P500.

Base Bid: All work on G001, P000, P101, & P500 less the supply, install, and completion of the associated work with the 2nd Heat Exchanger. The base bid also includes an allowance for the materials, termination, and programming for the base bid equipment controls (wiring and conduit are to be provided in the base bid).

Alternate #1: Supply and install the 2nd heat exchanger and its associated work. The alternate also includes an allowance for the materials, termination, and programming for the additional heat exchanger and associated equipment controls (wiring and conduit are to be provided in the base bid).

1. The Contractor's Work includes all labor, supervision, materials, equipment, services, supplies, tools, facilities, transportation, hoisting, storage, receiving, licenses, inspections, certifications, overhead, profit, or other items required or reasonably inferable to properly and timely perform and complete all work and services to be performed by the Contractor pursuant to this Agreement. Unless specifically stated otherwise, incidental work required to accomplish the work of this Bid Package shall be included the bid. This would include, but not be limited to, temporary facilities, protection of the work, security of equipment, materials, and work in progress, etc. Contractor's Work shall be performed in accordance with the Drawings and Specifications.
2. Contractor is responsible for all labor and equipment to unload, account for all material delivered, stock, and delivery for this scope of work. Storage and delivery of materials and equipment at the Site shall be permitted only to the extent approved in advance by the Construction Manager, and if anything, so stored obstructs the progress of any portion of the work, it shall be promptly removed or relocated by the Contractor without reimbursement.
3. On site supervision by Prime Contractor at all times work by that contractor or their subcontractors/suppliers is taking place.
4. Provide all temporary facilities required for this scope of work including trailer, trailer power, telephone, secured storage, temporary power for work, temporary and task lighting for work, etc. as determined necessary by Contractor. Coordinate location of trailers, material storage and utility lines with Construction Manager. Limited space is available, and permission to bring any such facility or excess materials on to the site shall be approved by the Construction Manager.
5. Contractor shall provide all equipment and tools for Contractor's own cleanup. Clean up shall be done at end of every shift or more frequently if required for the Contractor to perform their work, for other Contractors to perform their work, as required by the Owner's operations, and at the discretion of the Construction Manager.
6. All turf, landscaping, and subgrade disturbances caused by equipment traffic or other activities related to the Contractor's scope shall be repaired and or restored to proper conditions by the Facility. This contractor shall work to minimize any disturbance.
7. Protect adjacent existing building elements from damage from Scope of work. Repair existing building elements damaged during Contractor's Scope of work.
8. Contractor shall maintain an accurate set of As-Built Drawings throughout the duration of the project and submit to the Construction Manager at the completion of the project.

9332.00 - FDCF Bldg A Water Heater Replacement

1550 L St, Fort Dodge, IA 50501



SHEET INDEX

PLUMBING	
G001	COVER SHEET
P000	PLUMBING GENERAL INFORMATION
P101	MEZZANINE PLUMBING PLAN
P500	PLUMBING DETAILS AND SCHEDULES

CERTIFICATIONS

MECHANICAL ENGINEER

	I HEREBY CERTIFY THAT THIS ENGINEERING DOCUMENT WAS PREPARED BY ME OR UNDER MY DIRECT SUPERVISION AND THAT I AM A DULY LICENSED PROFESSIONAL ENGINEER UNDER THE LAWS OF THE STATE OF IOWA.	
	SIGNATURE	DATE: 3-27-2023
	PRINTED OR TYPED NAME: Tyson L. Scheidecker	
	LICENSE NUMBER: 21691	
MY LICENSE RENEWAL DATE IS DECEMBER 31, 2024		
PAGES, SHEETS OR DIVISIONS COVERED BY THIS SEAL: ALL SHEETS		

PROJECT DATE: PLAN DATE 3/21/23
PRE-BID MEETING 4/6/23

OWNER:
Iowa Department of Administrative Services
100 Southeast 13th Street
Des Moines, Iowa 50319

OWNER PROJECT NUMBER: 9332.00

OWNER REQUEST FOR BID NUMBER: RFQ 933200-01

CONSTRUCTION MANAGER:
McGough Construction
217 East 2nd Street, Suite 120
Des Moines, IA 50309

CONSTRUCTION MANAGER PROJECT NUMBER: 101031.002

PLUMBING ABBREVIATIONS

SYMBOLS	F	R
& @ #	AND AT NUMBER or POUND	RD RECIRC REFR REQD RHC RPM RPZ
A	ACO AD ADJ AFF AHJ ALT AMB AP APPROX AR AS ASSY ATM AUX AV AVG AW	ROOF DRAIN RECIRCULATE(ING) REFRIGERATION REQUIRED REHEAT COIL REVOLUTIONS PER MINUTE REDUCED PRESSURE ZONE
B	FLOOR CLEANOUT FLOOR DRAIN FIRE DEPARTMENT CONNECTION FEMALE PIPE THREAD FLOOR SINK FSEC FTHD FW FWP	S SCH SCHM SEER SF SHT SK SP SPEC SQ IN SS STBY STD STL SUCT SV SYS SRV
C	GENERAL CONTRACTOR GAS GAUGE GALLON GENERAL CONTRACTOR GPD GPH GPM GV GWH	SCHEDULE SCHEMATIC SEASONAL ENERGY EFFICIENCY RATIO SQUARE FEET SHEET SINK SUMP PUMP OR STATIC PRESSURE SPECIFICATION(S) SQUARE INCH STAINLESS STEEL STANDARDS STANDARD STEEL SUCTION SAFETY VALVE SYSTEM SAFETY RELIEF VALVE
D	HOT AND COLD WATER HOSE BIBB MERCURY HORIZONTAL HORSEPOWER HEATING, VENTILATION, AIR CONDITIONING HERTZ (FREQUENCY)	T TCC TD TEFC TEFC TEMP THRU TOP TP TYP
E	INSIDE DIAMETER INVERT ELEVATION INCHES INCHES (WATER COLUMN) INSULATION INSTRUMENT IRON PIPE IRON PIPE SIZE ISOMETRIC	U UL UNO UR UTIL
F	JANITOR'S SINK	V VAC VBOX VD VEL VERT VFD VTR
G	KELVIN KILOWATT KILOWATT HOUR	W W/
H	LAVATORY POUND(S) LEAVING WATER TEMPERATURE	W/
I	MAINTENANCE MAXIMUM BRITISH THERMAL UNIT (1000HR) MECHANICAL CONTRACTOR MOTOR CONTROL CENTER MINIMUM CIRCUIT AMPS MECHANICAL MANUFACTURER MINIMUM OR MINUTE MISCELLANEOUS MOTOR OPERATED VALVE MALE PIPE THREAD	W/O WB WC WH WHA WPD WT WTR
J	NOT APPLICABLE NORMALLY CLOSED NOT IN CONTRACT NORMALLY OPEN NOMINAL NATIONAL PIPE THREAD NOT TO SCALE	W/
K	OUTER DIAMETER OWNER FURNISHED CONTRACTOR INSTALLED OWNER FURNISHED OWNER INSTALLED OVERFLOW ROOF DRAIN OVERFLOW STORM	W/O WB WC WH WHA WPD WT WTR
L	NOT APPLICABLE NORMALLY CLOSED NOT IN CONTRACT NORMALLY OPEN NOMINAL NATIONAL PIPE THREAD NOT TO SCALE	W/
M	PRESSURE GAUGE OR PROPYLENE GLYCOL PHASE PLUMBING PRESSURE RELIEF VALVE OR PRESSURE REGULATING VALVE POUNDS PER SQUARE INCH ABSOLUTE POUNDS PER SQUARE INCH GAUGE	W/O WB WC WH WHA WPD WT WTR
N	NOT APPLICABLE NORMALLY CLOSED NOT IN CONTRACT NORMALLY OPEN NOMINAL NATIONAL PIPE THREAD NOT TO SCALE	W/
O	OUTER DIAMETER OWNER FURNISHED CONTRACTOR INSTALLED OWNER FURNISHED OWNER INSTALLED OVERFLOW ROOF DRAIN OVERFLOW STORM	W/O WB WC WH WHA WPD WT WTR
P	NOT APPLICABLE NORMALLY CLOSED NOT IN CONTRACT NORMALLY OPEN NOMINAL NATIONAL PIPE THREAD NOT TO SCALE	W/

PLUMBING SYMBOLS LEGEND

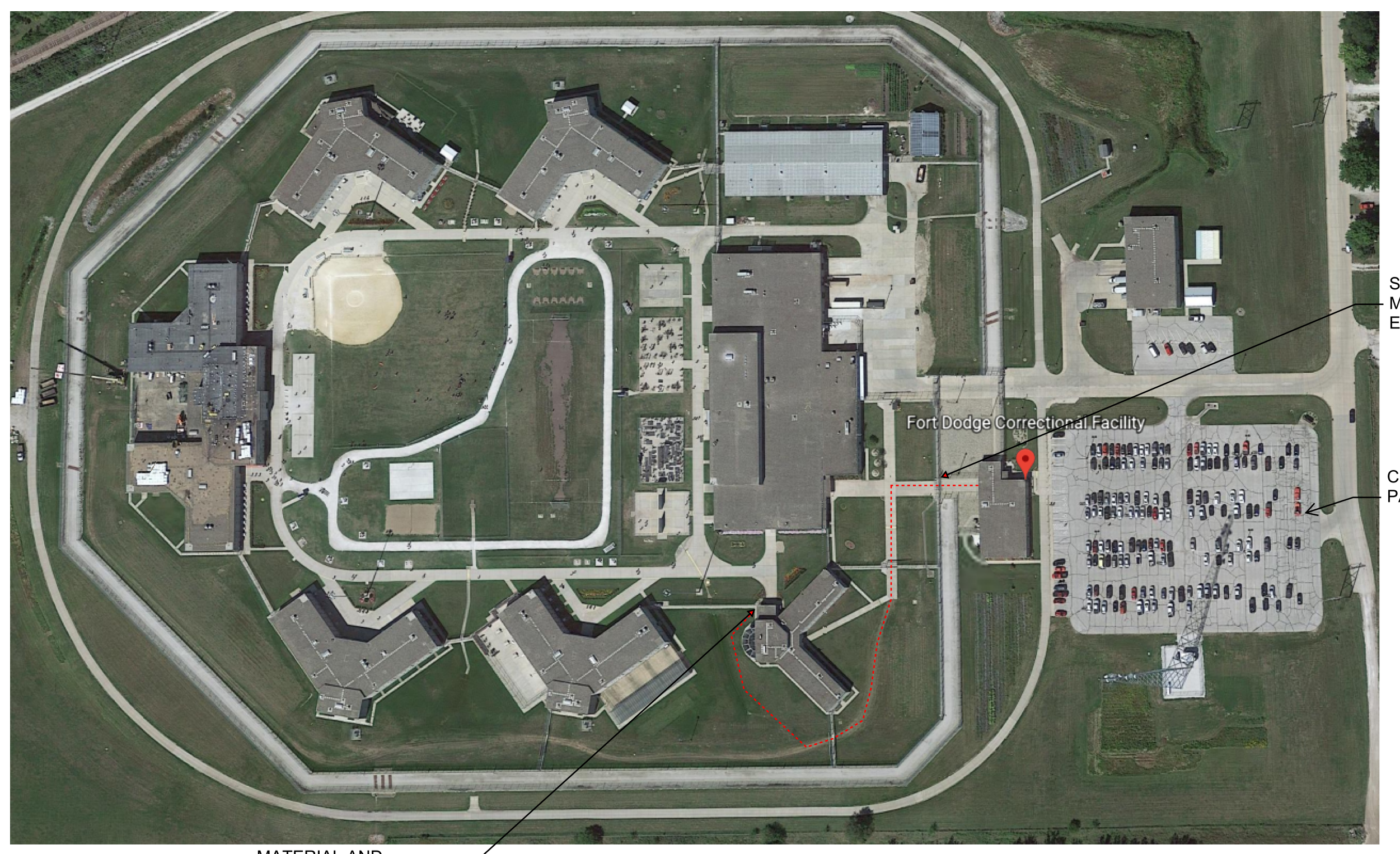
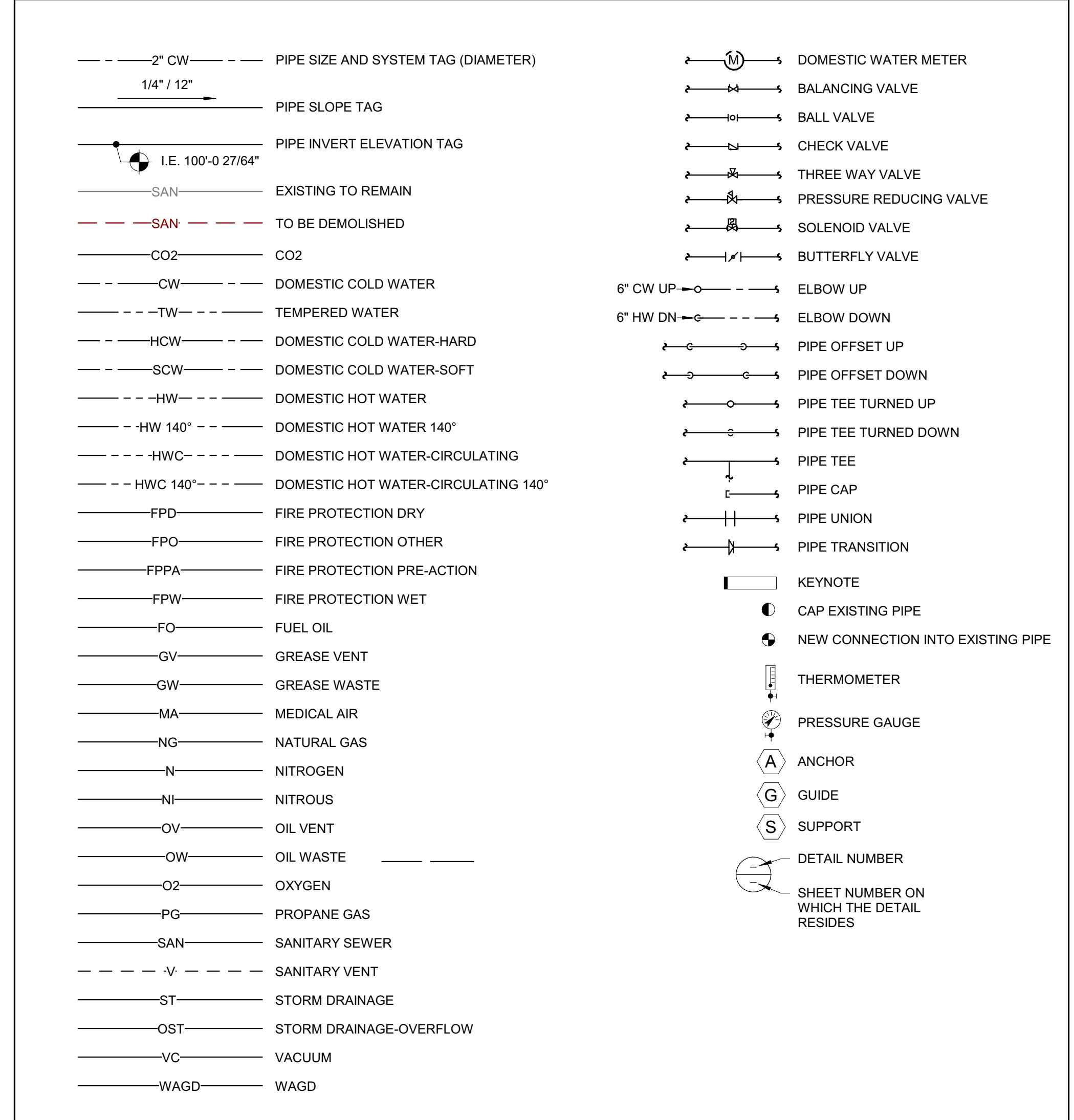

19332.00 - FDCF Bldg A Water Heater Replacement

Iowa Department of Administrative Services
1500 L St., Fort Dodge, IA 50501

DRAWN BY	ENIC
APPROVED BY	TLS
ISSUED FOR	ISSUED FOR BID
ISSUE DATE	3/27/2023
PROJECT NUMBER	214220160
FIELD BOOK	

**PLUMBING
GENERAL
INFORMATION**

P000

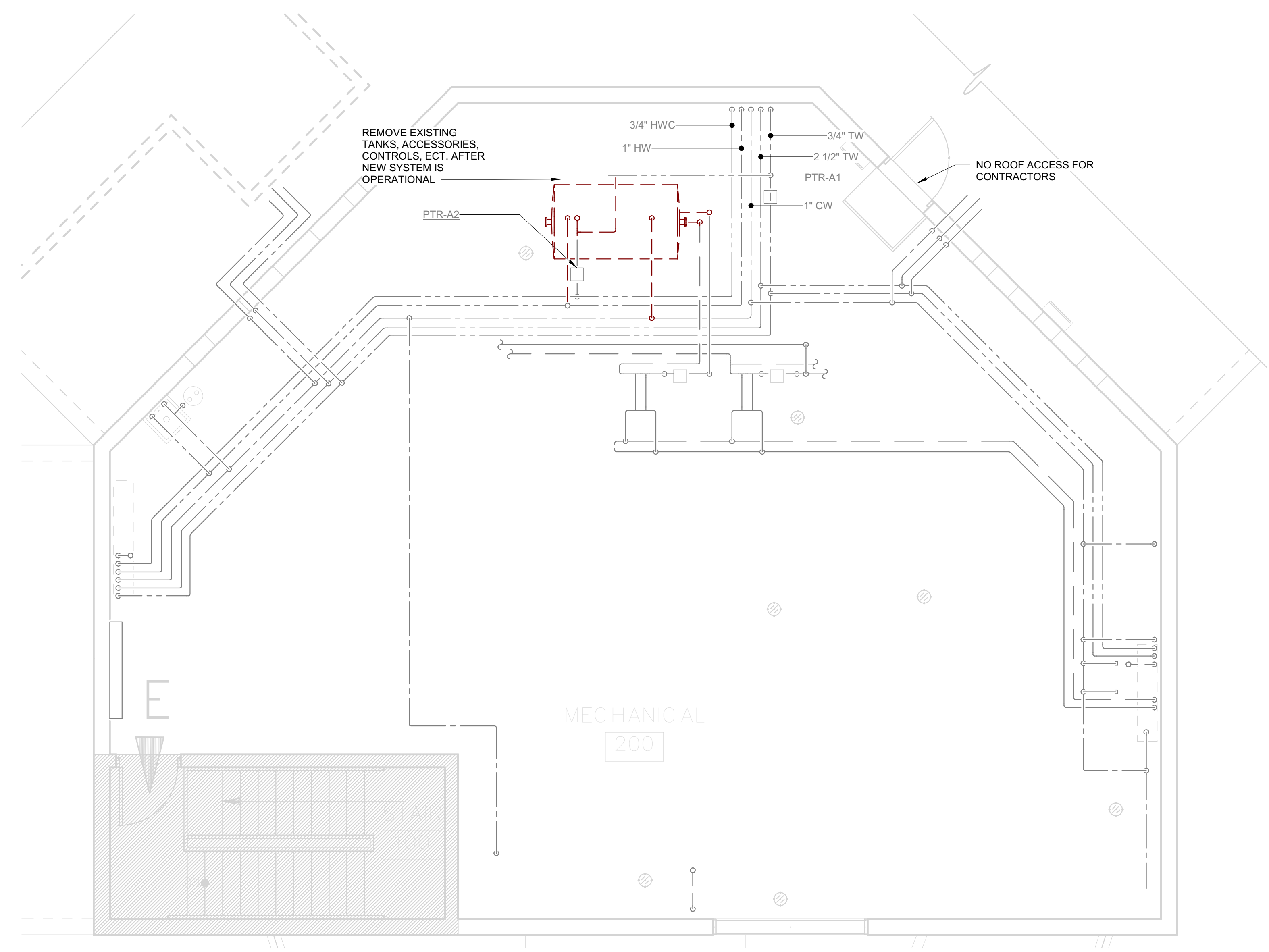

B3 MEZZANINE PLUMBING DEMOLITION PLAN
 1/4" = 1'-0" 0' 6"

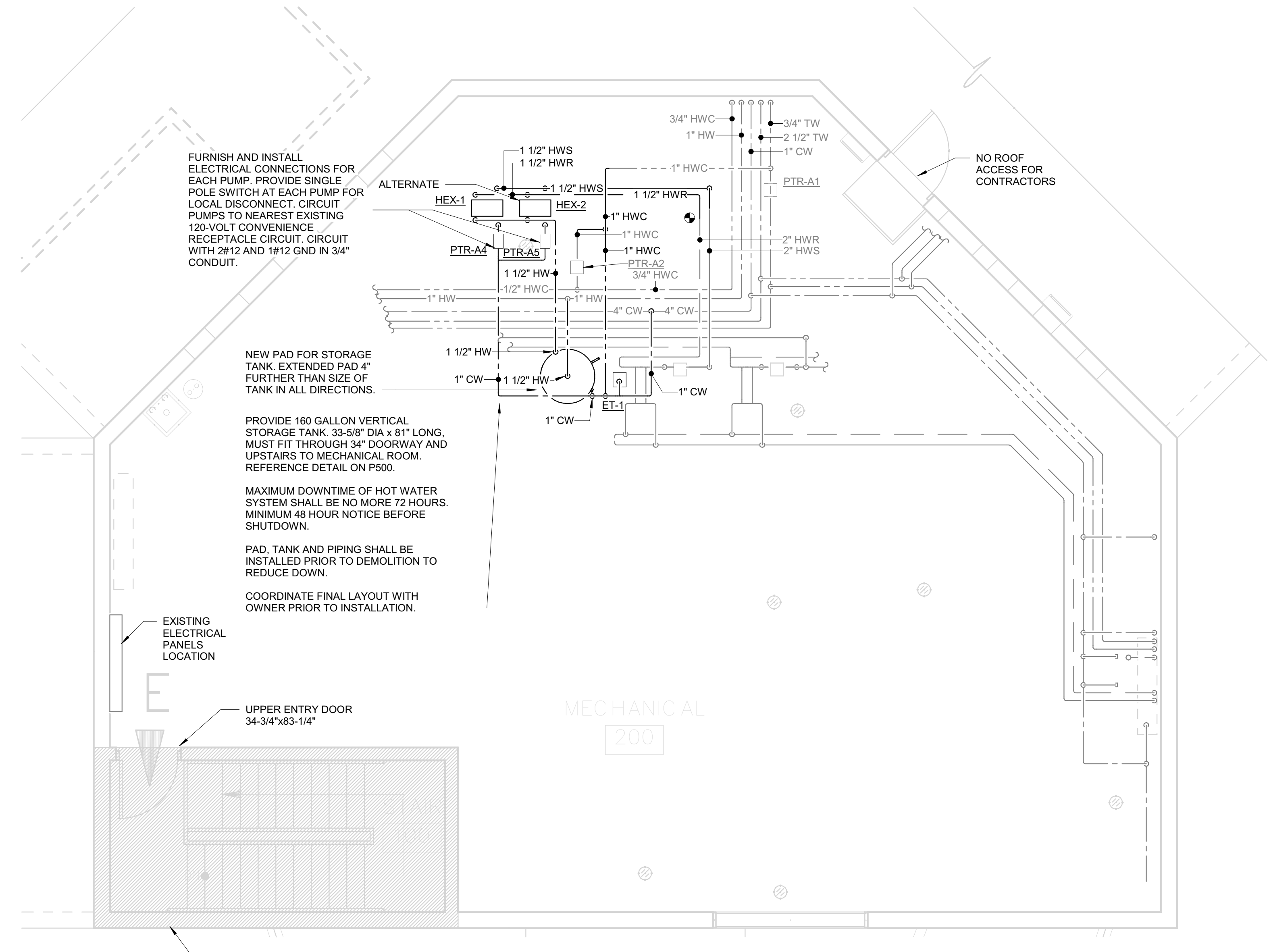

B6 MEZZANINE PLUMBING NEW WORK PLAN
 1/4" = 1'-0" 0' 6"

Autodesk Revit 2023
 Autodesk Docs (2142201160) BMS - FDCP Bldg A
 Water Heater Replacement (2142201160) BMS-214
 2/21/2023 10:27 AM

DRAWN BY	EMC
APPROVED BY	TLS
ISSUED FOR	ISSUED FOR BID
ISSUE DATE	3/21/2023
PROJECT NUMBER	2142201160
FIELD BOOK	

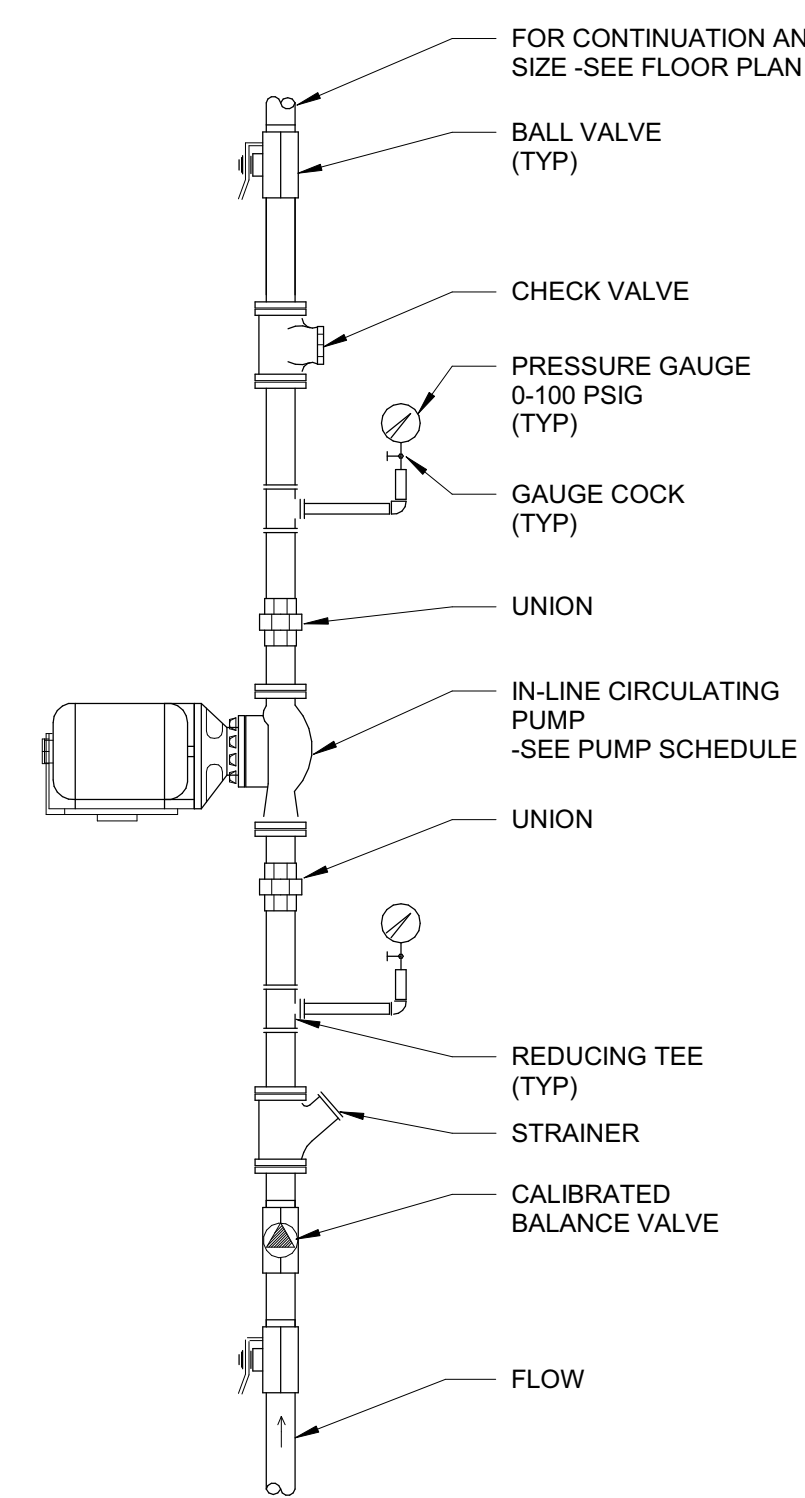

E3 Circulating Pump Details
NOT TO SCALE

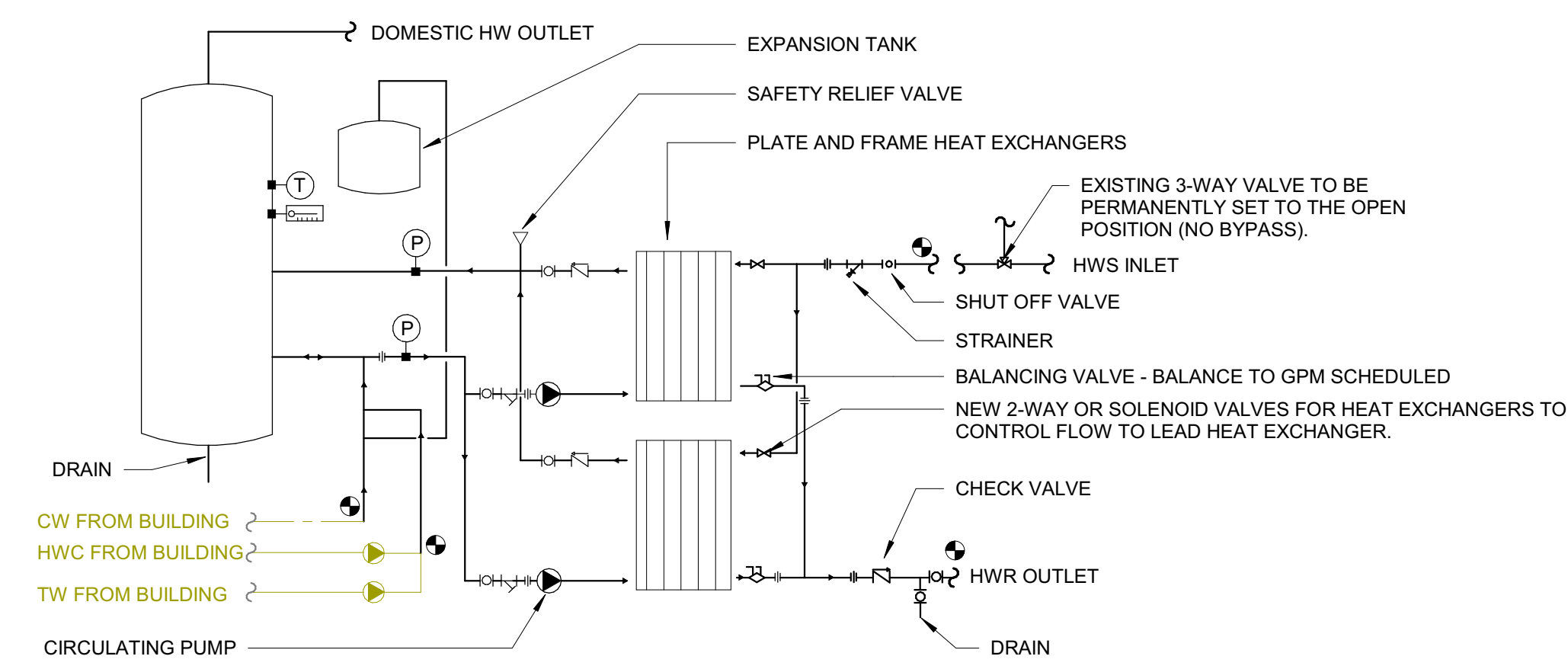

F2 DOMESTIC WATER HEAT EXCHANGER AND TANK DETAIL
NOT TO SCALE

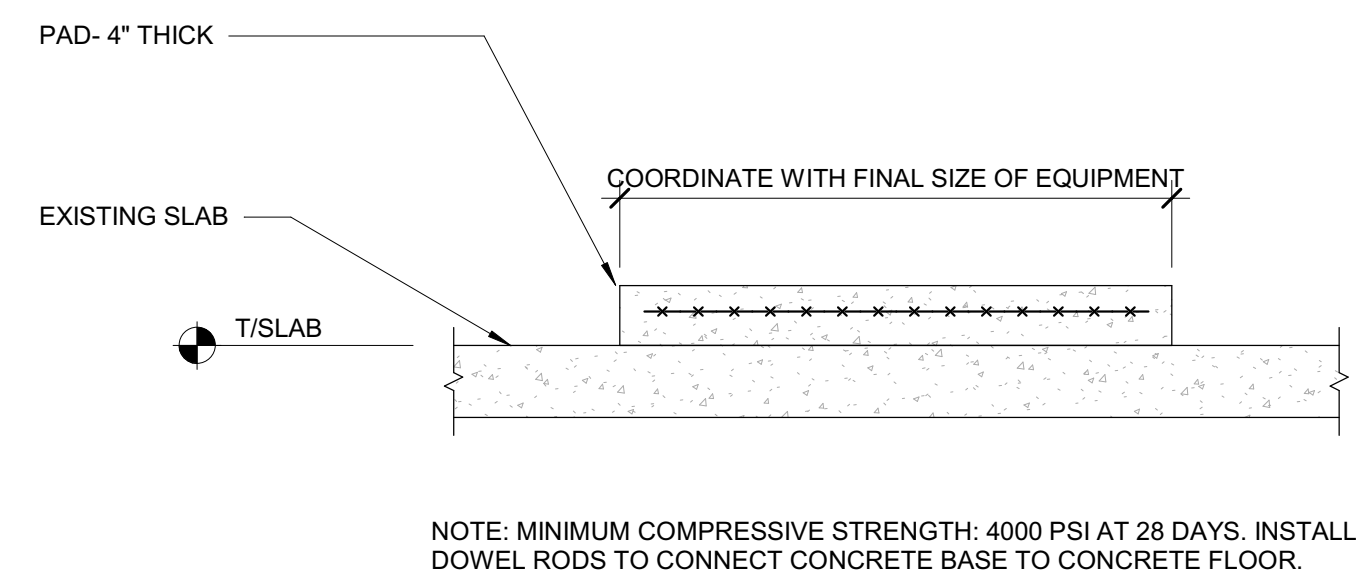

F3 TYPICAL HOUSEKEEPING PAD
NOT TO SCALE

PLUMBING EXPANSION TANK SCHEDULE

REMARKS:
1. SUBSTITUTIONS ALLOWED WITH ENGINEERS PRE-APPROVAL.

MARK	SYSTEM SERVED	TYPE	TANK CAPACITY (GAL)	ACCEPTANCE CAPACITY (GAL)	RELIEF VALVE		DESIGN BASIS	REMARKS
					RELIEF AT (PSI)	FILL AT (PSI)		
ET-1	COLD WATER	BLADDER	53	53	125	60	AMTROL ST-447-C	

HEAT EXCHANGER SCHEDULE - PLATE AND FRAME

REMARKS:
1. SUBSTITUTION ALLOWED WITH ENGINEERS PRE-APPROVAL.
2. PROVIDE SECOND HEAT EXCHANGER AS AN ADD ALTERNATE PRICING. IF ALTERNATE IS NOT TAKEN, PIPING TEES AND VALVES SHALL BE INSTALLED AND CAPPED FOR SECOND HEAT EXCHANGER AND CONTROLS CAPABLE OF ADDING SECOND HEAT EXCHANGER IN THE FUTURE.

MARK	HOT SIDE				COLD SIDE				DESIGN BASIS	REMARKS
	GPM	MAX PD (PSI)	EWI (°F)	LWT (°F)	GPM	MAX PD (PSI)	EWI (°F)	LWT (°F)		
HEX-1	19	10	185	162	5	1	40	140	DANFOSS PHE-NSF-61	
HEX-2	19	10	185	162	5	1	40	140	DANFOSS PHE-NSF-61	

PLUMBING PUMP SCHEDULE - WATTAGE

REMARKS:
1. SET PUMP TO CONSTANT SPEED. ON/OFF CONTROL TO BE PROVIDED THROUGH BAS SYSTEM.
2. SUBSTITUTIONS ALLOWED WITH ENGINEERS PRE-APPROVAL.
3. PROVIDE SECOND PUMP AS AN ADD ALTERNATE PRICING. IF ALTERNATE IS NOT TAKEN, PIPING TEES AND VALVES SHALL BE INSTALLED AND CAPPED FOR SECOND HEAT EXCHANGER AND CONTROLS CAPABLE OF ADDING SECOND PUMP IN THE FUTURE.

MARK	SYSTEM SERVED	TYPE	GPM	HEAD (FT)	SHUTOFF		MOTOR DATA		DESIGN BASIS	REMARKS
					HEAD (FT)	VOLTS / PHASE	HEAD (FT)	VOLTS / PHASE		
PTR-A4	COLD WATER	INLINE	5	5	6.5	208	1		B&G ECOCIRC 19-16	
PTR-A5	COLD WATER	INLINE	5	5	6.5	208	1		B&G ECOCIRC 19-16	

CONTROLS

EXISTING SEQUENCE OF OPERATIONS THROUGH SIEMENS DDC SYSTEM TO BE MODIFIED. UPDATE GRAPHICS TO REPRESENT NEW SYSTEM LAYOUT WITH PLATE & FRAME HEAT EXCHANGERS. SEPARATE STORAGE TANK AND ON/OFF VALVES ON HEAT EXCHANGERS.

PROVIDE NEW TEMPERATURE SENSOR FOR TANK AND PIPING. CONNECT TO NEW PUMPS TO TURN PUMPS ON AND OFF. PROVIDE ON/OFF STATUS OF PUMPS.

PROVIDE NEW ON/OFF VALVES FOR HEAT EXCHANGERS.

THE HEAT EXCHANGER AND ASSOCIATED PUMP SHALL BE ENABLED TO OPERATE WHENEVER THE PLANT BOILERS ARE ENABLED TO OPERATE.

THE DOMESTIC WATER TANK TEMPERATURE SETPOINT SHALL BE 135°F (ADJ.). ON A FALL TO 130°F (ADJ.), THE LEAD PUMP SHALL TURN ON AND ASSOCIATED ON/OFF VALVE SHALL OPEN. UPON REACHING SETPOINT, THE VALVE SHALL CLOSE AND THE PUMP TURNED OFF.

IF THE LEAD SYSTEM IS NOT ABLE TO MAINTAIN SETPOINT AFTER 30 MINUTES (ADJ.), THE LAG SYSTEM SHALL TURN ON AND OPERATE TO MAINTAIN TEMPERATURE.

THE LEAD PUMP AND HEAT EXCHANGER SHALL ROTATE UPON ONE OF THE FOLLOWING:

MANUALLY THROUGH A SOFTWARE SWITCH
 RUNTIME (ADJ.)
 DAILY
 WEEKLY
 MONTHLY

ALARMS SHALL BE PROVIDED AS FOLLOWS:
 HOT WATER PUMPS FAILURE (COMMANDED ON, BUT THE STATUS IS OFF)
 RUNNING IN HAND (COMMANDED OFF, BUT THE STATUS IS ON)

THE FOLLOWING TEMPERATURES SHALL BE MONITORED:
 HOT WATER SUPPLY
 HOT WATER RETURN
 TANK TEMPERATURE

EXCESSIVE TEMPERATURE FAILSAFE: IF TANK TEMPERATURE EXCEEDS 145°F (ADJ.), THE SYSTEM SHALL TURN OFF ALL PUMPS AND CLOSE ALL CONTROL VALVES AND ISSUE A HIGH TANK TEMPERATURE ALARM UNTIL RESET BY THE USER.

LOW WATER TEMPERATURE: AN ALARM SHALL BE SENT IF TANK WATER TEMPERATURE IS LOWER THAN 120°F (ADJ.)

EXISTING CONDUIT AND WIRING MAY BE REUSED

DRAWN BY	EMC
APPROVED BY	TLS
ISSUED FOR	ISSUED FOR BID
ISSUE DATE	3/21/2023
PROJECT NUMBER	2142301160
FIELD BOOK	

PLUMBING
DETAILS AND
SCHEDULES

**SECTION 22 0500
COMMON WORK RESULTS FOR PLUMBING**

PART 1 GENERAL

1.1 SECTION INCLUDES

- A. The work shall include the furnishings of systems, equipment and materials specified in this Division and as called for on the Plumbing Drawings to include supervision, quality control, operation, methods and labor for the fabrication, installation, start-up and tests for the complete plumbing installation. The work shall also include the furnishing of necessary hoisting facilities to set materials and equipment in place and the furnishing of any scaffolding and transportation associated with this work.
- B. Examine the project site and become familiar with existing conditions which will affect the work. Review the drawings and specifications of other trades and take note of conditions to be created which will affect the work. All conditions shall be considered in the preparation of bids; no additional compensation will be made on the behalf of this Contractor.
- C. Provide labor necessary to demolish the existing plumbing systems as shown on the drawings, as described in Part 3.1, Existing Conditions, or as required.
- D. Where noted on the drawings or where called for in other sections of the specification, the Contractor for this division shall install equipment furnished by others, and shall make required service connections. Verify with the supplier of the equipment the requirements for the installation. This contractor shall be responsible for the removal and installation of railings, piping, ductwork, louvers, etc. as required to install new equipment.

1.2 DAMAGE

- A. The Contractor shall be responsible for damage to the work of other trades, or to the building and its contents, caused by equipment installation.

1.3 PERMITS AND INSPECTIONS

- A. Obtain and furnish necessary permits and inspection certificates for material and labor furnished. Permits and certificates shall be obtained from the proper inspection authorities. The cost of permits, certificates and fees required in connection with the installation shall be borne by the Contractor, unless otherwise noted in the detailed contractual description preceding these specifications. Where applications are required for the procuring of utility services to the building, see that such application is properly filed with the utility, and that information required for such an application is presented to the extent and in the form required by the utility company.

1.4 CODES AND STANDARDS

- A. Standards listed by reference, including revisions by issuing authority, form a part of this specification section to the extent indicated. Standards listed are identified by issuing authority, authority abbreviation, designation number, title or other designation established by issuing authority. Standards subsequently referenced herein are referred to by issuing authority abbreviation and standard designation.
- B. Applicable provisions of the following codes and standards are hereby imposed on a general basis for the mechanical work in addition to specific applications specified by individual work sections of these specifications.

IA DAS - FDCF Bldg A Water Heater Replacement
Project # 2142301160

1. ANSI/ASME Pressure Piping Standards (B31)
 2. AWWA Standards
 3. ASME BPVC - Boiler and Pressure Vessel Code and State Boiler Code
 4. ICC (IECC) - International Energy Conservation Code
 5. ICC (IMC) - International Mechanical Code
 6. NFPA 70 - National Electrical Code
 7. Local and/or State Plumbing, Mechanical and Building Codes
 8. Occupational Safety and Health Act (OSHA)
 9. State of Iowa Plumbing Code
 10. NFPA Codes and Standards
- C. Any product used for dispensing potable water shall meet NSF 61 and NSF 372 testing standards. Third party testing shall be required.
- D. If any work indicated on the drawings or specified herein conflicts in any way with any of the rules and regulations of the above Authorities, the Contractor shall promptly notify the Architect/Engineer in writing and do so no less than 72 hours before bids are opened. In the event the Contractor fails to notify the Architect/Engineer and changes are required by said conflicts, the Contractor shall make such changes as are required without additional cost to this Owner.
- E. Installations must be safe in every respect and must not create a condition which will be harmful to building occupants; to operating, installing or testing personnel; to workmen; or to the public. The contractor for each installation shall be solely responsible for providing installations which will meet these conditions. If the Contractor believes that the installation will not be safe for all parties, report these beliefs in writing to the Architect/Engineer before any equipment is purchased or work is installed, giving recommendations. The Architect/Engineer will work out required changes and adjustments in contract price where adjustments are warranted.

1.5 DRAWINGS

- A. A complete set of up-to-date Project Drawings and Specifications shall be kept on the site at all times. Prior to installing any of the work, check the drawings for dimensions and see that the work does not interfere with clearance required for ceilings, beams, foundations, finished columns, pilasters, partitions, and electrical equipment as shown on the drawings and details. After work is installed and it develops that interferences occur which have not been called to the Architect/Engineer's attention before the installation, the Contractor shall, at his own expense, make such changes in his work as directed by the Architect/Engineer.
- B. The contract drawings for plumbing work are in part diagrammatic, intended to convey the scope of work and indicate general arrangement and approximate sizes and locations of equipment and materials. Where job conditions require reasonable changes in indicated locations and arrangement, the Contractor shall make such changes as directed by the Architect/Engineer, without additional cost to the Owner.
- C. Because of the scale of the drawings, certain basic items such as pipe fittings, access panels, and sleeves may not be shown; but where such items are required by other sections of these specifications or where they are required by the nature of the work, they shall be furnished and installed. Rough-in dimensions and locations shall be verified with the supplier of equipment furnished by other trades, or by the Owner, prior to the time of roughing-in.

- D. Equipment specification may not deal individually with minute items required such as components, parts, controls, and devices which may be required to produce the equipment performance specified, or as required to meet the equipment warranties. Where such items are required, they shall be included by the supplier of the equipment, whether or not specifically called for.
- E. The drawings and the specifications are cooperative and supplementary. It is the intent of both said drawings and specifications to cover all mechanical requirements in their entirety as nearly as possible. The Contractor shall closely check the drawings and specifications for any obvious errors or omissions and bring any such condition to the attention of the Architect/Engineer prior to the receipt of bids, in order to permit clarification by means of a mailed Addendum. If there is no question prior to the bid proposal date, the Architect/Engineer shall assume that the drawings and specifications are complete and correct and will expect the intent of said documents to be complied with, and the installation to be complete in all respects, according to said intent.
- F. Locate equipment which must be serviced, operated, or maintained in fully accessible positions. Minor deviations from the contract drawings may be made to allow for better accessibility, but changes of magnitude, or which involve extra cost, shall not be made without prior approval. Ample space shall be allowed for removal of parts that may require replacement or service in the future.
- G. All valves, pumps, etc. shall be accessible for maintenance purposes. Locate items carefully and coordinate with other trades so that each valve and piece of equipment is accessible and functional. Items located above a non-accessible ceiling, chase, or soffit shall be accessible through an access door. Coordinate location of access doors.

1.6 RESPONSIBILITY

- A. The Contractor's responsibility shall not end with the installation and connecting of the various apparatus. It shall include the services of an experienced superintendent, who shall be constantly in charge of the work, together with the qualified journeymen, helpers and laborers required to properly unload, install, connect, adjust, start, operate and test the work involved, including equipment and materials furnished by other trades or by the Owner, until such time as the entire plumbing installation functions properly in every detail.

1.7 COORDINATION

- A. Coordinate the work with other trades prior to installation.
- B. No piping or equipment, which is foreign to the electrical equipment, or architectural appurtenances shall be run over the top of any electrical panels or electrical equipment, in accordance with NEC 110.26. This does not prohibit sprinkler protection for the installation.
- C. The determination of quantities of material and equipment required shall be made from the drawings. Schedules on the drawings and in the specifications are completed as an aid, but where discrepancies arise, it shall be the Contractor's responsibility to provide the required quantity.
- D. Where the specifications state that equipment shall be furnished, installed, or provided, it shall be understood to mean this Contractor shall furnish and install completely, unless it is specifically stated that the equipment is to be furnished and installed by others.

**IA DAS - FDCF Bldg A Water Heater Replacement
Project # 2142301160**

- E. The Architect/Engineer reserves the right to determine space priority of the contractors in the event of interference between the piping and equipment of the various contractors. Conflicts between the drawings and specifications, or between requirements set forth for the various trades, shall be called to the attention of the Architect/Engineer. If clarification is not asked for prior to the taking of bids, it will be assumed that none is required, and that the Contractor has submitted his bid in conformance with plans and specifications as issued and that no interference exists.

1.8 GUARANTEE AND MAINTENANCE

- A. Materials and equipment shall be guaranteed to be free from defects and to be new equipment; no secondhand, used, or salvaged equipment will be allowed. The Owner's existing equipment which is to be relocated or reinstalled under this contract shall be refurbished, cleaned, and repaired, and made subject to the guarantee and maintenance as herein specified, unless specifically noted otherwise.
- B. Equipment which fails to meet performance ratings as specified and shown on the drawings shall be removed and replaced by new equipment that meets the specified requirements, without additional cost to the Owner.
- C. Materials and workmanship shall be subject to the review of the Architect/Engineer, in whose presence various tests shall be made as required by these specifications.

PART 2 PRODUCTS

2.1 SUBMITTALS

- A. Submit shop drawings and catalog data for plumbing equipment as called for in Division 01 - General Requirements.
- B. Submittal data for plumbing equipment shall consist of shop drawings and/or catalog cuts showing technical data necessary to evaluate the material or equipment to include dimensions, wiring diagrams, performance curves, rating, and other descriptive data necessary to describe fully the item proposed and its operating characteristics. Shop drawings shall be submitted on equipment and materials as required by the specifications.
- C. Approval of materials, including alternate or substitute items, shall be obtained in writing from the Architect/Engineer, verbal approval will not be considered binding.
- D. Shop drawings shall be submitted and shall have been signed, checked, approved, and initialed by the Contractor prior to submittal to the Architect/Engineer. The Architect/Engineer will review shop drawings to aid in interpreting the plans and specifications and will in so doing assume that the shop drawings conform to specified requirements set forth in this specification. The approval of the shop drawing by the Architect/Engineer does not relieve the Contractor of the responsibility of complying with elements of the specification. The name of the job, Architect/Engineer, location, and specification section shall appear on all pages of shop drawings. Equipment marks (such as S-1, WH-1) shall be indicated for each item.
- E. Near completion of project, before conducting Owner orientation and training sessions and before authorization of final payment, submit to the Owner or their designated Representative for review: three (3) sets of installation and operational information, parts lists, and maintenance instructional manuals. These OMMs shall be organized, formatted, and bound in accordance with Division 01 - General Requirements.

- F. At the completion of the project, prepare and submit to the Owner record drawings showing the location of piping and valves. Drawing shall give accurate dimensions of such equipment for future use by the Owner. This drawing shall be submitted as soon as work is completed and before authorization of final payment.

2.2 SUBCONTRACTORS AND MATERIALS

- A. Submit to the Architect/Engineer for review, when requested, a list of subcontractors, materials and equipment proposed to be used. The list must be reviewed by the Architect/Engineer before this Contractor may enter into any subcontractual agreement. Equipment, materials, and devices, etc. shall be subject to the review of the Architect/Engineer, whether or not said items are herein specified.

2.3 STANDARDS OF MATERIALS AND WORKMANSHIP

- A. Materials shall be new, complete with manufacturer's guarantee or warranty, and shall be as listed by Underwriters Laboratories (UL), Inc., American Water Works Association (AWWA), American Gas Association (AGA), etc., if a standard has been established by that agency for the type of material.
- B. Materials shall also comply with applicable standards of the National Electrical Manufacturer's Association, National Board of Fire Underwriters, National Fire Protection Association, National Safety Council, National Bureau of Standards, the National Electrical Code and the Williams-Steiger Occupational Safety and Health Act of 1970. Such standards are hereby made a part of these specifications.
- C. Work shall be performed by workmen skilled in the particular craft, shall be executed in a workmanlike manner, and shall present a neat mechanical appearance when completed. Align, level and adjust equipment for satisfactory operation, and install so that connecting and disconnecting of piping and accessories can be made readily and so that parts are easily accessible for inspection, operation and maintenance. Methods and techniques of installation shall be subject to the review of the Architect/Engineer.
- D. Materials shall be the standard product of a reputable manufacturer regularly engaged in the manufacture of the specific product. Materials of the same type of class shall be the products of one manufacturer. For example, faucets shall be from the same manufacturer.
- E. Materials shall be protected from damage and stored indoors or protected from the weather at all times, unless other storage arrangements are approved by the Architect/Engineer.
- F. Material and equipment shall be installed in strict accordance with the manufacturer's recommendations.

2.4 MATERIAL SUBSTITUTIONS

- A. Proposals as submitted shall be based on the products specifically named in the specification or on the drawings. Material or equipment by manufacturers other than those specified may be used only by permission of the Architect/Engineer. Such permission for substitution must be requested, in writing and in accordance with Division 01 - General Requirements.
- B. The Architect/Engineer reserves the sole right for the approval of proposed material or equipment, and the phrase, "or approved equivalent", used in these specifications, or on the drawings, shall be interpreted to mean an equivalent approved by the Architect/Engineer.
- C. Changes required by alternate equipment shall be made at no additional cost to the Owner; and costs incurred by other trades, public utilities, or the Owner, as a result of the use of such equipment, shall be the responsibility of the Contractor.

IA DAS - FDCF Bldg A Water Heater Replacement
Project # 2142301160

- D. Furnish to the Architect/Engineer, when requested, samples of proposed material or equipment substitutions. These samples shall remain with the Architect/Engineer as long as needed.
- E. Identify the differences in alternate material or equipment as compared to that specified and indicate the benefits to the project as a result of selecting the alternative.
- F. The Architect/Engineer reserves the right to refuse approval of equipment which does not meet the specification, in their opinion, or of equipment for which no local experience of satisfactory service is available. The Architect/Engineer further reserves the right to reject equipment for which maintenance service and the availability of replacement parts is questionable.

2.5 JOINING MATERIALS

- A. Refer to individual Division 22 piping sections for special joining materials not listed below.
- B. Solder Filler Metals: ASTM B 32, lead-free alloys. Include water-flushable flux according to ASTM B 813.

2.6 DIELECTRIC FITTINGS

- A. Description: Combination fitting of copper alloy and ferrous materials with threaded, solder-joint, plain, or weld-neck end connections that match piping system materials.
- B. Insulating Material: Suitable for system fluid, pressure, and temperature.
- C. Dielectric Unions: Factory-fabricated, union assembly, for 250-psig (1725-kPa) minimum working pressure at 180 deg F (82 deg C).
 - 1. Available Manufacturers:
 - a. Capitol Manufacturing Co.
 - b. Central Plastics Company.
 - c. Eclipse, Inc.
 - d. Epco Sales, Inc.
 - e. Hart Industries, International, Inc.
 - f. Watts Industries, Inc.; Water Products Div.
 - g. Zurn Industries, Inc.; Wilkins Div.
 - h. Engineer Pre-Approved Equivalent

PART 3 EXECUTION

3.1 EXISTING CONDITIONS

- A. Examine the existing buildings and grounds or site and become familiar with the conditions as they exist, or that will in any manner affect the work under this contract. No allowance will be made subsequently, in this connection, on behalf of the Contractor for any error or negligence by the Contractor.

- B. Existing equipment, such as duct or pipe, in or on the existing building and grounds which is to be replaced, or which interferes in any way with the remodeling of the existing facilities and/or installation of new equipment, shall be removed from the premises or relocated by this Contractor, as directed by the Architect/Engineer. Do not remove from the premises any equipment that may have maintenance value to the Owner without permission of the Owner. Equipment, duct, or pipe not to be reused shall be removed from the premises, unless otherwise noted herein or shown on the drawings.
- C. Where existing equipment is removed or changed, all piping no longer in service shall be removed and stubs plugged as directed by the Architect/Engineer. Building surfaces damaged and openings left by removal of equipment shall be repaired by the proper trades and paid for by this Contractor, unless otherwise noted on the drawings. The cutting and fitting shall be done by this Contractor. The cutting of floor, ceiling or wall surfaces shall be done by this Contractor with extreme care, in order to avoid any disrupting or damage of existing utility services which may be encountered. Coordinate with other trades and with the Construction Manager to minimize the damage to the building in order to reduce the amount of patching required.
- D. Where new openings are cut and concealed piping is encountered, such items shall be removed or relocated as required. Where systems to be removed stub through floors, walls or ceilings, openings shall be patched so that no evidence of the former installation remains.
- E. Existing active services (water, gas, sewer, electric), when encountered, shall be protected against damage. Do not prevent or disturb operation of active services that are to remain. If active services are encountered which require relocation, make request to authorities with jurisdiction for determination of procedures. Where existing services are to be abandoned, they shall be terminated in conformance with requirements of the utility or municipality having jurisdiction.
- F. The location, size and elevation of underground utilities shown on the drawings are in accordance with data supplied by the Owner and/or the various utility companies. The Contractor shall verify this data and shall report any discrepancies to the Architect/Engineer, in writing, before submitting his bid.

3.2 INTERRUPTION OF SERVICE

- A. Changes in service shall be made so as to provide a minimum of interference with the operation of services in the building. When changes require shutdown of building services, notify the proper building authorities no less than 48 hours in advance and obtain approval from these authorities before making changes. Such notices shall give duration and nature of shutdown. Temporary arrangements shall be approved by the Architect/Engineer and/or Owner.
- B. Any and all interruptions to building services shall be in accordance with Division 01 - General Requirements.

3.3 PIPING SYSTEMS - COMMON REQUIREMENTS

- A. Drawing plans, schematics, and diagrams indicate general location and arrangement of piping systems. Indicated locations and arrangements were used to size pipe and calculate friction loss, expansion, pump sizing, and other design considerations. Install piping as indicated unless deviations to layout are approved on Coordination Drawings.
- B. Install piping in concealed locations, unless otherwise indicated and except in equipment rooms and service areas.

**IA DAS - FDCF Bldg A Water Heater Replacement
Project # 2142301160**

- C. Install piping indicated to be exposed and piping in equipment rooms and service areas at right angles or parallel to building walls. Diagonal runs are prohibited unless specifically indicated otherwise.
- D. Install piping above accessible ceilings to allow sufficient space for ceiling panel removal.
- E. Install piping at indicated slopes.
- F. Install fittings for changes in direction and branch connections.
- G. Install piping to allow application of insulation.
- H. Select system components with pressure rating equal to or greater than system operating pressure.

3.4 OPENINGS, CUTTING, AND PATCHING

- A. Coordinate the placing of openings in the new structure, as required for the installation of the plumbing work.
- B. Furnish the accurate locations and sizes for required openings. This shall not relieve this Contractor of the responsibility of checking to assure that proper size openings are provided. When additional patching is required due to this Contractor's failure to inspect this work, this Contractor shall make arrangements for the patching required to properly close the opening, to include patch painting. This Contractor shall pay any additional cost incurred in this respect.
- C. When cutting and patching of the structure is made necessary due to this Contractor's failure to install piping, sleeves, or equipment on schedule, or due to this Contractor's failure to furnish, on schedule, the information required for the leaving of openings, it shall be this Contractor's responsibility to make arrangements for this cutting and patching. This Contractor shall pay any additional cost incurred in this respect.
- D. Provide cutting and patching and patch painting in the existing structure, as required for the installation of the work. Furnish lintels and supports as required for openings. Cutting of structural support members will not be permitted without prior approval of the Architect/Engineer. Extent of cutting shall be minimized. Use core drills, power saws or other machines which will provide neat, minimum openings. Patching shall match adjacent materials and textures and shall be performed by craftsmen skilled in the respective craft required.

3.5 CONCRETE AND MASONRY WORK

- A. Concrete bases and pads for mechanical equipment shall be furnished by this Contractor. Size bases to extend minimum of 4" beyond equipment base in any direction, and 4" above finished floor elevation. Construct of reinforced concrete, roughen floor slab beneath base for bond, and provide steel rod anchors between floor and base. Locate anchor bolts using equipment manufacturer's templates. Chamfer top and edge corners.
- B. Locate, furnish, and install all support, hanger and equipment anchor bolts and related hardware.

3.6 PAINTING

- A. The finish of any item that has been marred, scratched, or damaged in any way by this Contractor shall be repainted at the expense of this Contractor, and to the satisfaction of the Architect/Engineer and the Owner.

3.7 CLEANING

- A. Keep the premises clean of all dirt and debris, caused by the work in accordance with Division 01 - General Requirements.
- B. Keep the premises clean of all debris caused by the work at all times, and keep materials stored, in areas designated by the Owner, in such a manner as not to interfere with the progress of the work of other Contractors or with the operation of existing facilities.
- C. At the conclusion of the construction, the site shall be thoroughly cleaned of all rubble, debris and unused material and shall be left in good order. Closed off spaces shall be cleaned of waste such as material, cartons, and wood frame members used in the construction.

3.8 SUSPENSION FROM WOOD STRUCTURAL MEMBERS

- A. In general, concentrated or other loads shall not be suspended directly from the bottom of wood structural members, unless approved by the Architect/Engineer. Loads suspended from open web joists or trusses may be transferred to the bottom chord of the structural member at the panel points. Loads suspended from solid web joists shall be transferred to the joists only through the top flange or web. Suspension systems shall be reviewed by the Architect/Engineer.

3.9 WIRING FOR PLUMBING EQUIPMENT

- A. The Division 26 Contractor shall provide power including connection to all electrically powered equipment furnished by the Division 22 Contractor. Where electrical disconnect switches are not explicitly specified to be furnished as part of Division 22 equipment, the Electrical Contractor shall furnish suitable type(s) and properly rated electrical disconnect switches for all said mechanical equipment.
- B. Provide integral wiring, alarm wiring, control wiring, temperature control wiring and interlock wiring for equipment furnished, whether or not such wiring is furnished by the equipment vendor.
- C. Except as noted otherwise or where other sections call for motor starters to be furnished by manufacturers as part of their equipment, the Division 26 Electrical Contractor shall furnish motor starters as required for motors furnished by this Division 22 Contractor.
- D. Furnish shop drawings including but not limited to detailed schedules and wiring diagrams to other interested trades including Division 26 electrical contractor for all electrically powered equipment furnished. Schedules shall include: electrical loads and characteristics, max. overcurrent fuse protection / circuit breaker needs, disconnect requirements, motor starter requirements and motor horsepower(s). Include drawings as needed to depict locations of electrical and control panels, service clearances, disconnects as well as wiring connection points.
- E. The Division 22 Contractor shall be responsible to pay for all additional costs incurred due to equipment substitutions by Division 22 Contractor, which require either larger electrical service or service of a different electrical characteristic than scheduled on the Drawings.
- F. Prior to bid submission, this Division 22 Contractor shall review the Electrical Drawings and promptly bring to the attention of the Architect/Engineer, any omissions or errors in the electrical services required for equipment proposed to be furnished.

3.10 PROTECTION

- A. Special steps shall be taken as necessary for the protection of equipment and materials furnished under Division 22. Equipment and materials shall be protected by Contractor from any physical damage due to weather elements, dirt, dents, sheet rock installation, and painting until the project is completed. Damage, if incurred, shall be promptly repaired at no additional cost to Owner, as-needed to restore equipment and materials to original as-new condition.
- B. Protection of equipment during the finishing (sheet rock, plastering and painting) of the building interior shall be the responsibility of the contractor or contractors performing that work. This shall not relieve this Division 22 Contractor of the ultimate responsibility of checking and ensuring that adequate protection is provided and maintained at all times.
- C. Where the installation or connection of equipment requires Division 22 Contractor to work in areas previously finished by other Contractors, the Division 22 Contractor shall be responsible to ensure that such finished areas are adequately protected and are not marred, soiled or otherwise damaged during the course of their said work. If damage occurs this Division 22 Contractor shall be responsible to arrange for the other Contractors to repair and refinish any damaged areas and shall pay for all repair, rework and refinishing required.
- D. When heavy materials must be placed upon or transported over the roof deck, sheeting shall be placed to distribute the weight and support such materials. Any damage shall be immediately corrected at no cost to the Owner.

3.11 ASBESTOS IDENTIFICATION AND CONTROL

- A. In the event that suspected asbestos containing material (ACM) is encountered during the course of the work, cease operations in the immediate area and promptly notify both the Owner and Architect/Engineer. Suspected materials will then be sampled and analyzed by the Owner's Representative.
- B. Should ACM be confirmed, the Owner's Representative shall direct the abatement procedures. This work shall be awarded either by subcontract to the Contractor or under a separate contract.
- C. During abatement operations, cease operations in the immediate area of the abatement. Operations in other areas of the project may be performed, but care must be taken to control dust to avoid contamination of air monitoring samples. The Contractors shall coordinate activities with the asbestos abatement contractor as well as the Owner's Representative.
- D. Should no ACM be identified, operations in the restricted areas may be resumed. At the discretion of the Owner or Owner's representative, any schedule delays caused by identification, analysis or abatement may be added in the form of an extension of time to the contract via a Change Order.

3.12 NOISE AND VIBRATION

- A. Contractor shall install all equipment in a such a manner so as to control the transmission of noise and vibration from any installed equipment, components or systems, so the sound level in any occupied area does not exceed NC-35 levels. Contractor shall correct all objectionable noise levels in any occupied areas and at no additional cost to Owner, which are due to improperly installed or isolated equipment, components, or systems.

3.13 TESTS AND DEMONSTRATIONS

- A. Systems shall be tested and placed in proper working order prior to demonstrating systems to the Owner.
- B. Prior to acceptance of the plumbing installation, demonstrate to the Owner or his designated representatives essential features and functions of all systems installed, and instruct the Owner in the proper operation and maintenance of such systems.
- C. Furnish the necessary trained personnel to perform the demonstrations and instructions, and arrange to have the manufacturer's representatives for the system present to assist with the demonstrations. The Owner and Contractor shall each sign a certification stating that the training has been performed and the Owner accepts same.

END OF SECTION

This page intentionally left blank

**SECTION 22 0523
GENERAL DUTY VALVES FOR PLUMBING PIPING**

PART 1 GENERAL

1.1 SECTION INCLUDES:

- A. Provide equipment, materials, labor, and supervision necessary to install valves as indicated on drawings and in schedules, and herein specified.
- B. Valves of the same type shall be of a single manufacturer.
- C. Valves shall conform to ANSI standard dimensions.
- D. ASME Compliance:
 - 1. ASME B16.10 for ferrous valve dimensions.
 - 2. ASME B31.9 for building services piping valves.
- E. NSF Compliance: NSF/ANSI 61 and/or NSF/ANSI 372 for valve materials for potable-water service. Valves for domestic water must be 3rd Party Certified.

1.2 SUBMITTALS

- A. Submit detailed Product Data clearly indicating manufacturer, model, size, dimensions and pressure rating.
- B. For records documentation submit valve schedule, indicating valve ID, type, size and intended service and location.

1.3 PACKAGING

- A. Valves shall be furnished or provided with protective packaging to prevent damage during shipping or on the job site.
- B. Prepare valves for shipping as follows:
 - 1. Protect internal parts against rust and corrosion.
 - 2. Protect threads, flange faces, grooves, and weld ends.
 - 3. Set angle, and globe valves closed to prevent rattling.
 - 4. Set ball and plug valves open to minimize exposure of functional surfaces.
 - 5. Set butterfly valves closed or slightly open.
 - 6. Block check valves in either closed or open position.
- C. Use the following precautions during storage:
 - 1. Maintain valve end protection.
 - 2. Store valves indoors and maintain at higher than ambient dew point temperature. If outdoor storage is necessary, store valves off the ground in watertight enclosures.
- D. Use sling to handle large valves; rig sling to avoid damage to exposed parts. Do not use handwheels or stems as lifting or rigging points.

**IA DAS - FDCF Bldg A Water Heater Replacement
Project # 2142301160**

1.4 DEFINITIONS

- A. CWP: Cold Working Pressure
- B. EPDM: Ethylene Propylene Copolymer Rubber
- C. NBR: Acrylonitrile-Butadiene, Buna-N, or Nitrile Rubber
- D. PTFE: Polytetrafluoroethylene Plastic
- E. SSP - Saturated Steam Pressure
- F. WP - Working Pressure
- G. SWP - Steam Working Pressure
- H. W.O.G. - Water, Oil, Gas Pressure
- I. BR - Bronze
- J. I.B.B.M. - Iron Body, Bronze-Mounted
- K. O.S.&Y. - Outside Screw and Yoke
- L. N.R.S. - Non-Rising Stem
- M. R.S. - Rising Stem
- N. M.S.S. - Manufacturer's Standardization Society of the Valve and Fitting Industry, Inc.
- O. Lead Free: Refers to the wetted surface of pipe, fittings and fixtures in potable water systems that have a weighted average lead content =0.25% per Safe Drinking Water Act as amended January 4, 2011, Section 1417.

PART 2 PRODUCTS

2.1 GENERAL

- A. Materials: Discs, gaskets, packings, seats, diaphragms, and lubricants shall conform to recommendations of the valve manufacturer for the intended use.
- B. Body materials, unless otherwise stated:
 - 1. Bronze: 125-150 lbs., ASTM B62
- C. Lead Free silicon bronze (ASTM listed) valves shall be made with corrosion-resistant materials. Manufacturer shall provide third party certification tested in accordance with EN ISO 6509 regarding dezincification corrosion resistance and stress corrosion cracking.
- D. Bronze Valves: NPS 2 (DN 50) and smaller with threaded or solder ends, unless otherwise indicated.
- E. Valve Pressure and Temperature Ratings: Not less than indicated and as required for system pressures and temperatures.
- F. Valve Sizes: Same as upstream piping unless otherwise indicated.
- G. Valve-End Connections:
 - 1. Solder Joint: With sockets according to ASME B16.18.
 - 2. Threaded: With threads according to ASME B1.20.1.
 - 3. Copper Press: With sockets according to ASME B16.22/ASTM B75.

- H. Valves in Insulated Piping: With 2-inch stem extensions and the following features:
1. Ball Valves: With extended operating handle of non-thermal-conductive material that meets UL 2043 approved for inside air plenum, and protective sleeve that allows operation of valve without breaking the vapor seal or disturbing insulation and memory stops that are fully adjustable after insulation is applied.

2.2 MANUFACTURERS

- A. Subject to compliance with requirements, provide products manufactured by one of the following, as listed for each valve type, or Engineer Pre-Approved Equivalent.

Valve Type	Approved Manufacturer
Globe, and Check Valves	Crane, Stockham, Lunkenheimer, Hammond Industrial Series, NIBCO, Milwaukee
Ball Valves	Jamesbury, Apollo, Jenkins, Milwaukee, Watts, Worchester, Powell, or NIBCO

2.3 GLOBE VALVES

- A. Provide globe valves complying with MSS SP-80. Globe valves shall be installed where shown on the drawings for tight shutoff and shall be as follows:
1. 2 in. and smaller: 150-lb. saturated steam, rising stem, bronze body meeting ASTM B62 bronze trim, stainless steel disc and seat, union bonnet with stuffing box.
 2. Equip valves with packing suitable for intended service.
 3. Provide globe valves such that the back seating protects packing and stem threads from fluid when valve is fully opened. Equip valves with gland follower.

2.4 CHECK VALVES

- A. Provide check valves complying with MSS SP-71 or for water, steam, and air shall be as follows unless otherwise shown on the drawings:
- B. Lift Check Valves:
1. Silicone Bronze, 200 CWP, Lift Check Valves with Nonmetallic TFE Disc:
 - a. Description:
 - 1) Standard: MSS SP-139.
 - 2) CWP Rating: 200 psig.
 - 3) Body Design: Vertical or horizontal flow.
 - 4) Body Material: Silicon bronze (ASTM Listed), corrosion resistant
 - 5) Ends: Threaded or soldered.
 - 6) Disc: TFE.

2.5 BALL VALVES

- A. Provide ball valves complying with MSS SP-72 or MSS SP-110. Ball valves shall be as follows unless otherwise indicated on the drawings.
1. 2 in. and smaller: ASTM B584 bronze body, 2-piece, full port stainless steel brass ball, screwed or soldered ends with teflon seats and seals, blow out proof stem, tee or lever handle rated to 150 SWP/600WOG.

IA DAS - FDCF Bldg A Water Heater Replacement
Project # 2142301160

2.6 DRAIN VALVES (HOSE BIBBS)

- A. Soldered or Threaded Ends: Bronze body, screwed bonnet, rising stem, composition disc, 3/4 in. threaded hose outlet connection; 125 psi maximum pressure rating.

2.7 ACTUATORS, HANDWHEELS, OPERATORS, HANDLES, AND WRENCHES

- A. Provide suitable handwheels for gate, globe and drain valves.
- B. Valve Actuator Types:
 - 1. Handwheel: For valves other than quarter-turn types.
 - 2. Hand lever: For quarter-turn valves NPS 6 (DN 150) and smaller.

PART 3 EXECUTION

3.1 VALVE LOCATIONS – GENERAL

- A. Unless otherwise noted, shutoff valves shall be provided at all equipment connections (supply and return where applicable) for the following piping: pump suction and discharge, water, air, fuel and gas and drain lines (except on gravity drains from pans). Equipment connections include such items as tanks, pumps, heat exchangers, and similar items.
- B. Check valves of the non-slam type shall be installed at the discharge of pumps unless otherwise shown on the drawings.
- C. Install isolation valves at each branch off of horizontal mains and vertical risers.

3.2 EXAMINATION

- A. Examine valve interior for cleanliness, freedom from foreign matter, and corrosion. Remove special packing materials, such as blocks, used to prevent this movement during shipping and handling.
- B. Operate valves in positions from fully open to fully closed. Examine guides and seats made accessible by such operations.
- C. Examine threads on valve and mating pipe for form and cleanliness.
- D. Examine mating flange faces for conditions that might cause leakage. Check bolting for proper size, length, and material. Verify that gasket is of proper size, that its material composition is suitable for service, and that it is free from defects and damage.
- E. Do not attempt to repair defective valves; replace with new valves.

3.3 VALVE INSTALLATION

- A. Follow the manufacturer's recommended installation instructions concerning soldering, silver brazing, welding, threading, and installation of flanged valves in order to prevent damage to the valve and assure its maximum efficiency. Additional specific installation requirements are as follows:
 - 1. Thread pipe for threaded valves to standard length only, using new block dies.
 - 2. Put pipe compound on the pipe end, not into the valve threads. Securely screw pipe and valve together.
 - 3. Blow out or otherwise thoroughly clean pipe sections before they are installed.

4. Close valve before installation.
 5. Secure and adjust valves for no leaks and for easy operation.
 6. Install valves with stems horizontal or vertical above the pipe and square with building construction. Install valves in position to allow full stem movement.
 7. Install valves so piping does not place a stress or strain on the valve body. Locate valves for easy access and provide separate support where necessary.
 8. Install extended-stem valves where insulation is indicated. Stems shall be extended such that the handle moves freely without contact with the insulation.
 9. Install drain valves at low points of piping, at each mechanical equipment item, and elsewhere, where indicated.
 10. Locate valves, cock, and hose bibbs to allow easy accessibility for operation, maintenance and repair.
 11. Lugged butterfly valves with rubber-lined seats shall be installed with the disc(s) partially open. Bolts shall be torqued to the manufacturer's recommendations.
- B. Install valves with unions or flanges at each piece of equipment arranged to allow service, maintenance, and equipment removal without system shutdown.
- C. Install check valves for proper direction of flow and as follows:
1. Swing Check Valves: In horizontal position with hinge pin level.
- D. When soldering use paste fluxes that are approved by the manufacturer for use with Lead Free Alloys.

3.4 ADJUSTING

- A. Adjust or replace valve packing after piping systems have been tested and put into service but before final adjusting and balancing. Replace valves if persistent leaking occurs.

3.5 GENERAL REQUIREMENTS FOR VALVE APPLICATIONS

- A. Drawings indicate valve types to be used. If valve applications are not indicated, use the following:
1. Shutoff Service: Ball valves.
 - a. Piping NPS 2 (DN 50) and smaller: Furnish bronze ball valves.
 2. Throttling - Balancing Service: Globe valves.
 - a. Piping NPS 2 (DN 50) and smaller: Furnish bronze globe valves.
 3. Hot-Water Piping, Balancing Duty: Memory-stop balancing valves.
 4. Drain Duty: Hose-end drain valves.
 5. Pump-Discharge Check Valves:
 - a. NPS 2 (DN 50) and Smaller: Spring-loaded lift valves with nonmetallic disc.
- B. Install shutoff valve close to water main on each branch and riser serving plumbing fixtures or equipment, on each water supply to equipment, and on each water supply to plumbing fixtures that do not have supply stops. Use ball or gate valves for piping NPS 2 (DN 50) and smaller.

IA DAS - FDCF Bldg A Water Heater Replacement
Project # 2142301160

- C. Install drain valves for equipment at base of each water riser, at low points in horizontal piping, and where required to drain water piping.
 - 1. Install hose-end drain valves at low points in water mains, risers, and branches.
 - 2. Install stop-and-waste drain valves where indicated.
- D. Install calibrated balancing valves in discharge side of each pump and circulator. Set calibrated balancing valves partly open to restrict but not stop flow. Calibrated balancing valves are specified in Division 22 Section "Domestic Water Piping Specialties."
- E. If valves with specified CWP ratings are not available, the same types of valves with CWP ratings may be substituted.
- F. Select valves, except wafer types, with the following end connections:
 - 1. For Copper Tubing, NPS 2 (DN 50) and Smaller: Threaded, Sweat solder, or Press-to-fit ends.

END OF SECTION

**SECTION 22 0529
HANGERS AND SUPPORTS FOR PLUMBING PIPING AND EQUIPMENT**

PART 1 GENERAL

1.1 SECTION INCLUDES

- A. Provide equipment, materials, labor, and supervision necessary to install pipe hangers and supports.
- B. Pipe support systems shall secure pipes in place, prevent pipe vibration, provide vertical adjustment for maintaining required grades, and provide for expansion and contraction.
- C. Where supports are attached to concrete or other structural members, care shall be taken to prevent damage or weakening of the structural members.
- D. Where concrete inserts are to be used, it shall be this Contractor's responsibility to accurately locate and attach inserts to concrete forms.

1.2 REFERENCE STANDARDS

- A. American National Standards Institute, ANSI:
 - 1. ANSI B31.1 Power Piping.
 - 2. ANSI B31.9 Building Services Piping.
- B. Manufacturers Standardization Society of the Valve and Fittings Industry, MSS, 1815 North Fort Myer Drive, Arlington, VA 22209.
 - 1. MSS SP-58: Pipe Hangers and Supports - Materials, Design and Manufacturer.
 - 2. MSS SP-69: Pipe Hangers and Supports - Selection and Application.
- C. Anvil International, 2 Holland Way, Exeter, NH 03833, www.anvilintl.com, (603) 418-2800.
 - 1. Pipe Hangers and Supports Catalog (Jan. 2015).

1.3 DEFINITIONS

- A. Pipe Hanger: A device normally suspended from structure and is used to carry the piping weight in tension.
- B. Pipe Support: A device by which piping is normally carried from beneath and is used to carry the piping weight in compression.

1.4 SUBMITTALS

- A. Submit manufacturer's product data on all hangers and support devices. Product data to include, but not be limited to materials, finishes, approvals, load ratings, and dimensional information.

PART 2 PRODUCTS

2.1 HANGERS AND SUPPORTS

- A. Hangers and support devices shall be Anvil International Inc., Tolco, Fee and Mason, Michigan, B-Line or Engineer approved equivalent. Figure numbers within are based on Anvil International, Inc.

PART 3 EXECUTION

3.1 INSTALLATION - HORIZONTAL PIPE SUPPORTS

- A. Hanger rods for copper pipe and tube shall be installed in accordance with MSS-SP-69 Tables 3 and 4 and the following schedule:

Pipe Size	Rod Diameter	Maximum Spacing
1/2" and 3/4"	3/8"	5'-0"
1"	3/8"	6'-0"
1 1/4"	3/8"	7'-0"
1 1/2"	3/8"	8'-0"
2"	3/8"	8'-0"
2 1/2"	1/2"	9'-0"
3", 3 1/2", and 4"	1/2"	10'-0"
5"	1/2"	13'-0"
6"	5/8"	14'-0"
8"	3/4"	16'-0"

- B. Support horizontal cast iron soil pipe with two hangers for each pipe length. Locate hangers close to couplings.
- C. In addition to the above specified spacings, install additional hangers at change in pipe direction and at concentrated loads, large valves, and strainers.
- D. Where more than one pipe is to be run parallel together, they may be supported on trapeze type hangers. Trapeze bar angles and hanger rods shall be of sufficient size to support the particular group of pipes. Trapeze hanger spacing shall be based on the smallest pipe on the rack. When hanging from light gauge metal trusses, coordinate pipe hanger spacing and hanger rod connection points with the truss manufacturer.
- E. For suspending hanger rods from brackets attached to walls, use welded steel brackets: Fig. 194 for loads up to 750 lbs; Fig. 195 for loads up to 1500 lbs; Fig. 199 for loads up to 3000 lbs.
- F. Where pipes are to be racked along walls, use "Unistrut" pipe racks or 12 gauge steel strut channel, 1-5/8" x 1-5/8" minimum.
 - 1. Mount pipes to strut channel with two-piece pipe straps to match outside diameter of pipe including insulation.
- G. Attach all pipe hangers from support rods using double locknuts tightened to prevent loosening.

3.2 INSTALLATION - VERTICAL PIPE SUPPORTS

- A. Support vertical steel, wrought iron, copper and brass pipe at every other floor line.
- B. Support vertical cast iron soil pipe at every floor line.
- C. In addition to the above, support vertical pipes at base of riser with base fitting set on concrete or brick pier, or by hanger located on horizontal connection close to riser.
- D. Where pipe sleeves extend above floor, place pipe clamps at ceiling below and support clamp extensions from inserts or other approved attachment.

3.3 PIPE ATTACHMENTS

- A. For horizontal copper pipe and tube, use copper-plated, carbon steel adjustable swivel ring, Fig. CT-69.
- B. When thermal expansion for horizontal pipe is in excess of ½" axially, use adjustable steel yoke pipe roll, Fig. 181, or adjustable pipe roll stand, Fig. 177.
- C. For vertical copper pipe and tube, use copper-plated, copper plated copper tubing riser pipe clamp, Fig. CT-121.

3.4 INTERMEDIATE ATTACHMENTS

- A. Hanger rods: Carbon steel single or double end threaded, Figs. 140, 253 as required. Continuous threaded rod, Fig. 146 may be used wherever possible.
- B. Chain wire or perforated strap hangers will not be permitted. One pipe shall not be suspended from another pipe.

3.5 STRUCTURAL ATTACHMENTS

- A. For attaching steel or copper plated hanger rods to reinforced concrete, use galvanized malleable iron universal concrete inserts; Fig. 282 for loads up to 1140 lbs.
- B. For attaching steel hanger rods to structural steel beams, use malleable iron C-clamps; Fig. 92, Fig. 93 or Fig. 94 with retaining clip Fig. 89 or Fig. 89X for loads up to 500 lbs; Fig. 218 with extension piece for loads up to 1,365 lbs. For copper plated hanger rods, use copper plated malleable iron C-clamps; Fig. CT-138R for loads up to 180 lbs.
- C. For attaching steel hanger rods to wood structural members, use malleable iron ceiling flange; Fig. 153 for loads up to 1,270 lbs. For copper plated hanger rods, use copper plated malleable iron ceiling flange: Fig. CT-128R for loads up to 180 lbs.
- D. Vertical expansion shields or toggles shall not be used for suspending hanger rods, except with permission in cases where inserts have been omitted or cannot be used. If permitted, use expansion shields; for rod sizes up to ½", 320 lbs. max. load. For hanger rods larger than ½" use attachment plate, Fig. 52, with wedge anchors.
- E. Powder actuated anchoring methods shall not be used.

3.6 PIPE COVERING PROTECTION

- A. Hangers and supports for insulated piping shall not injure or pierce insulation. Provide insulation protection shields in conjunction with hanger or roll device. Use Fig. 160 and 165, Protection Saddles.

IA DAS - FDCF Bldg A Water Heater Replacement
Project # 2142301160

3.7 SUPPLEMENTAL STEEL

- A. Provide supplemental steel as required to hang or support plumbing equipment or piping.

END OF SECTION

**SECTION 22 0553
IDENTIFICATION FOR PIPING AND EQUIPMENT**

PART 1 GENERAL

1.1 SECTION INCLUDES

- A. Provide materials, equipment labor and supervision necessary to install piping identification products.
- B. Comply with ANSI A13.1 for lettering size, length or color field, colors, and installed viewing angles of identification devices.

1.2 REFERENCE STANDARDS

- A. ASME A13.1 - Scheme for the Identification of Piping Systems; The American Society of Mechanical Engineers; 2007.
- B. ASTM D709 - Standard Specification for Laminated Thermosetting Materials; 2013.

1.3 SUBMITTALS

- A. Submit manufacturer's product data.
- B. Submit sample of each type of identification product and clearly identify the contents in a schedule.
- C. List: Submit list of wording, symbols, letter size, and color coding for mechanical identification.
- D. Schedule:
 - 1. Submit valve schedule for each system, typewritten and reproduced on 8-1/2" x 11" bond paper. Tabulate valve ID tag number, system, system abbreviation (as shown on tag), location of valve (room or space), and variations for identification (if any). Mark valves that are intended for emergency shut-off and similar special uses, by special "flags" in margin of schedule.

PART 2 PRODUCTS

2.1 MANUFACTURERS

- A. Brady Corp., Industrial Safety Supply, Emedco, Seton or Brimar.
- B. Engineer pre-approved alternative.

2.2 PIPE MARKERS

- A. Provide manufacturer's standard preprinted, semi-rigid snap-on or self-sticking, color-coded pipe markers, complying with ANSI A13.1.
- B. Provide full-band pipe markers, extending 360° around pipe at each location or self-sticking pipe markers, fastened in the following method:
 - 1. Snap-on application of pre-tensioned semi-rigid plastic pipe marker.
 - 2. Secure to piping and install banding tape on both ends of each pipe label.

- C. Lettering shall be manufacturer's pre-printed nomenclature which best describes piping system in each instance, as selected by Architect/Engineer in cases of variance.
- D. Print each pipe marker with arrows indicating direction of flow, integrally with piping system service lettering (to accommodate both directions), or as separate unit of plastic or on banding tape.

2.3 EQUIPMENT MARKERS

- A. Provide engraved signage nameplates and tags constructed of multi-layered acrylic that has been treated for outdoor use and can withstand temperatures up to 160° F. Nameplates shall have beveled edges with contrasting color core, letters, and border. Minimum size of nameplate shall be 3" high by 6" long. The minimum letter height shall be 3/4". Attachment shall be by double faced 2 mil permanent acrylic adhesive. For equipment that doesn't allow for direct attachment, furnish sheet metal backing to integrate with equipment such that signage can be read from 5 feet above the finished floor. Unless noted otherwise, signage shall be provided with black lettering, black border, and yellow core. All signage shall include up to 14 characters per line, minimum of 3 lines per tag. Furnish signage for equipment shown in Section 3:
 - 1. All pumps shall include the full name description for system served.
- B. All equipment shall be named consistent with the plans and specifications as indicated on the schedules or as directed by the Owner.

2.4 BRASS VALVE TAGS

- A. Provide manufacturer's standard brass valve tags with stamped black filled lettering, with piping system abbreviation in 1/4" high letters and sequenced valve numbers 1/2" high, and with 3/16" hole for fastener.
- B. Provide 1-1/2" round brass tags with black lettering. Seton 250 BL or equal.

2.5 VALVE TAG FASTENERS

- A. Manufacturer's standard solid brass chain or solid brass S-hooks of sizes required for proper attachment of tags to valves and manufactured specifically for that purpose.

2.6 VALVE SCHEDULE FRAMES

- A. For each page of schedule, provide glazed display frame, with screws for removable mounting on masonry walls. Provide frames of finished hardwood or extruded aluminum, with SSD-grade sheet glass.

2.7 PIPING AND EQUIPMENT IDENTIFICATION

- A. Piping systems that shall be identified by their controls (including directional arrows) on this project shall include, but are not necessarily limited to the following:
 - 1. Domestic cold water, hot water, and hot water recirculation.
 - 2. Heating water supply and return.

- B. Provide name plates for all equipment scheduled on the drawings. Coordinate nameplate tag with Owner's sequencing system. If the Owner has no preference, the nameplates shall correspond with the equipment schedule. Equipment shall include but is not limited to the following:
1. Pumps.
 2. Heat Exchangers.
 3. Expansion Tanks.
 4. Storage Tanks.

PART 3 EXECUTION

3.1 INSTALLATION OF MECHANICAL IDENTIFICATION

- A. Where identification is to be applied to surfaces that require insulation, painting or other covering or finish, including valve tags in finished mechanical spaces, install identification after completion of covering and painting. Install identification prior to installation of acoustical ceilings and similar removable concealment.
- B. Install pipe markers on each system and include arrows to show normal direction of flow.
- C. Locate pipe markers as follows: wherever piping is exposed to view in occupied spaces, machine rooms, accessible maintenance spaces (shafts, tunnels, plenums) above lay-in type ceilings and exterior non-concealed locations.
1. Near each valve and control device.
 2. Near each branch, excluding short take-offs for fixtures, mark each pipe at branch where there could be question of flow pattern.
 3. Near locations where pipes pass through walls or floors/ceilings, (both sides) or center non-accessible enclosures.
 4. At access doors, manholes, and similar access points that permit view of concealed piping.
 5. Near major equipment items and other points of origination and termination.
 6. At each pipe passage to underground.
 7. Spaced intermediately at maximum spacing of 50 feet along each piping run, except reduce spacing to 25 feet in congested areas of piping and equipment.
 8. On piping above removable acoustical ceilings, maximum spacing of 10 feet along each piping run.
 9. Where self-sticking labels are used, the pipe or its covering surface shall be properly prepared. This consists of removal of loose dirt, oil and grease, loose paint or peeling insulation covering. This can be done with a brush and cloth; washing is not required. Use solvent for removal of oil or grease.
 10. Banding tape must be used on both ends of all self-sticking labels. The tape shall encircle the pipe completely and overlap itself so the banding tape can adhere to itself.
- D. Provide valve tags for all major valves 1/2" size or larger. Included are all main, zone and branch valves, valves in all equipment rooms, etc. All types of valves, ball, globe, butterfly, cocks, control, regulating, relief, reducing, solenoid, etc. are to be identified except check valves. Do not identify end use point valves for plumbing fixtures, and similar rough-in connections.

IA DAS - FDCF Bldg A Water Heater Replacement
Project # 2142301160

- E. List each tagged valve in schedule for each system showing function and location. Provide separate charts for mechanical divisions of work. Charts shall be installed on a conspicuous wall in the main mechanical equipment room. Provide unframed copies of valve lists as part of closeout documents.

3.2 ADJUSTING AND CLEANING

- A. Relocate any mechanical identification device which has become visually blocked by work of this division or by other divisions.
- B. Clean face of identification devices and glass frames of valve schedules.

END OF SECTION

**SECTION 22 0700
PIPING INSULATION**

PART 1 GENERAL

1.1 SECTION INCLUDES

- A. Provide equipment, materials, labor, and supervision necessary to install insulation to hot and cold surfaces of piping, tanks, ductwork, fittings and other surfaces.
- B. Insulation shall include insulating materials, jackets, adhesive, mastic coatings, tie wire and other materials as required to complete the insulating work.

1.2 CODES AND STANDARDS

- A. Insulating materials, jackets and mastics shall meet flame spread, fuel contribution and smoke developed ratings in accordance with NFPA-90A. Flame spread rating in accordance with NFPA 255, ASTM E-84, or UL 723 of not more than 25; smoke developed rating of not more than 50, unless otherwise noted in this section.
- B. Insulation that has been treated with a flame-retardant additive to meet the flame spread and smoke developed ratings shown above is not permitted.
- C. Insulation materials shall be non-corrosive to the materials they are applied to, including stress corrosion cracking of stainless steel and shall not breed or promote mold, fungus, or bacteria.
- D. Insulation shall meet or exceed all requirements of IECC - International Energy Conservation Code .

1.3 QUALIFICATION

- A. Insulating materials by Owens-Corning, Armacell, Pittsburgh-Corning, Knauf, Johns Manville, or Engineer approved equivalent.
- B. Mastics and adhesives as recommended by insulation manufacturer.

1.4 SUBMITTALS

- A. Product Data: Submit manufacturer's technical product data and installation instructions for each type of mechanical insulation and jacket. Submit schedule showing manufacturer's product number, flame spread and smoke development rating, k-value, density, temperature limitations, sound absorption coefficients, thickness, and furnished accessories for each mechanical system requiring insulation.

PART 2 PRODUCTS

2.1 INSULATION

A. Description:

1. Type A: Preformed, sectional, heavy density fiberglass insulation, suitable for operating temperatures form - 20° F to +850° F. Equipped with factory-applied, all-service vapor barrier jacket constructed of white Kraft paper bonded to aluminum foil reinforced with fiberglass yarn, with pressure-sensitive, self-sealing longitudinal laps and butt strips. Thermal conductivity of 0.23 BTU-in/hr-ft2- F @ 75° F mean temperature. Water vapor permeance of 0.02 perms. Johns Manville "Micro-Lok HP or Engineer approved equivalent.
2. Type B: Flexible, elastomeric pipe and sheet insulation with closed-cell structure. Shall comply with ASTM C534, Type I, Grade 1 for tubular materials and ASTM C534 Type II, Grade 1 for sheet materials. Suitable for operating temperatures from -40° F to 220° F. Outdoor applications, and where otherwise noted, shall receive a weather-resistant, protective, latex enamel finish. Thermal conductivity of 0.28 BTU-in/hr-ft2-°F @ 75° F mean temperature. Water vapor permeance of 0.08 perms. Insulation shall be equivalent to Armacell AP Armaflex; adhesive equivalent to Armacell Armaflex 520 or Armaflex 520 BLV Low-VOC Contact Adhesive; finish equivalent to Armacell Armaflex WB finish.
3. Type C: Flexible, elastomeric thermal insulation with an expanded, closed-cell structure. Pre-slit tubular form with a pressure-sensitive adhesive strip for closure and vapor sealing of the longitudinal joint. Butt joints, sealed with 3M-471 tape. White color. Suitable for operating temperature of 40° F to 200° F. Thermal conductivity of 0.28 BTU-in/hr-ft2-°F mean temperature. Water vapor permeance of 0.20 perms. Insulation shall be Armacell Self-Seal Armaflex 2000 or Engineer approved equivalent.

2.2 PIPE INSULATION SCHEDULE (IECC - INTERNATIONAL ENERGY CONSERVATION CODE)

SERVICE	TYPE	THICKNESS	PIPE SIZES
DOMESTIC COLD WATER	A, B, OR C	1/2"	LESS THAN 1-1/2"
		1"	1-1/2" AND LARGER
DOMESTIC HOT WATER (UP TO 140 DEG F) INCL HW CIRC	A, B, OR C	1"	LESS THAN 1-1/2"
		1-1/2"	1-1/2" AND LARGER
HEATING WATER (141F-201F)	A	1-1/2"	LESS THAN 4"
		2"	4" AND LARGER

2.3 INSULATION JACKETS

- A. 20-mil high impact PVC secured with spray contact adhesive. All PVC jacketing shall meet the 25/50 SDR. Manville "Zeston 2000" or equivalent.
- B. 6-oz/sq yd UL listed cotton canvas fabric secured with Childers CP50 lagging adhesive or Engineer Pre-Approved Equivalent.

- C. Fitting and valve jackets shall be premolded PVC with joints and seams sealed with a spray contact adhesive or vapor barrier mastic. Premolded jackets shall be Manville "Zeston 2000" or Engineer Pre-Approved Equivalent.
- D. Where PVC or metal jackets are used, delete the factory applied ASJ on pipe and equipment operating above 75° F.
- E. PVC jackets shall be used in the following areas and systems:
 - 1. Premolded PVC at all fittings and valve jackets.

PART 3 EXECUTION

3.1 GENERAL

- A. Use only experienced applicators regularly engaged in the trade. Rough work will be rejected. Application details shall be in accordance with the insulation materials supplier's recommendations, except where a higher standard is specified.
- B. Install materials after systems have been tested and approved. Material such as rust, scale, dirt, and moisture shall be removed from surfaces to be insulated.
- C. Insulation shall be kept clean and dry at all times.
- D. Where pipes and ducts pass through fire rated walls, floors and partitions, a fire seal shall be provided.
- E. When flexible cellular insulation is used, it shall be installed with seams and joints sealed with contact adhesive.
 - 1. Wherever possible, the insulation shall be placed over the pipe before it is installed. Seal the butt joints with Armacell Armaflex 520, or Armaflex 520 BLV Low-VOC Contact Adhesive or equal.
 - 2. Where the insulation cannot be slipped on, cut the insulation longitudinally and apply it to the piping. Seal longitudinal seam and butt joints with Armacell Armaflex 520 adhesive, or Armaflex 520 BLV Low-VOC Contact Adhesive or equal. In all cases, the insulation, equal to Armacell AP, protected with half-round PVC sleeves the length of three times the nominal pipe size, minimum length to be 8 inches.

3.2 PIPE INSULATION INSTALLATION

- A. Insulate fittings, valves, unions, flanges, strainers, flexible connections, and expansion joints with premolded or mitered segments of same insulating material as for adjacent pipe covering.
- B. Pipe insulation shall continue through sleeves and hangers with vapor barrier and/or jacket.
- C. Insert to be between support shield and piping but under the finish jacket. Provide an insert at hangars not less than 6 inches long, of same thickness and contour as adjoining insulation, to prevent insulation from sagging at support points. Inserts shall be heavy density insulating material suitable for the planned temperature range. Factory fabricated inserts may be used.
- D. Neatly finish insulation at supports, protrusions, and interruptions.
 - 1. On hot systems where fittings are to be left exposed, insulation ends shall be beveled away from bolts for easy access.
 - 2. On cold systems, valve stems shall be sealed with caulking which allows free movement of the stem, but provides a seal against moisture incursion.

IA DAS - FDCF Bldg A Water Heater Replacement
Project # 2142301160

- E. Wherever piping penetrates a floor or is exposed in a finished area such as kitchens, furnish a floor pipe escutcheon and/or PVC (white) jacket to protect insulation and allow for a smooth finish for cleaning.

END OF SECTION

**SECTION 22 1005
PLUMBING PIPING**

PART 1 GENERAL

1.1 SECTION INCLUDES

- A. Pipe, pipe fittings, specialties, and connections for piping systems.
 - 1. Domestic water.
 - 2. Strainers.

1.2 RELATED REQUIREMENTS

- A. Section 22 0553 - Identification for Plumbing Piping and Equipment.

1.3 REFERENCE STANDARDS

- A. ANSI Z21.22 - American National Standard for Relief Valves for Hot Water Supply Systems 2015 (Reaffirmed 2020).
- B. ASME B16.18 - Cast Copper Alloy Solder Joint Pressure Fittings 2021.
- C. ASME B16.22 - Wrought Copper and Copper Alloy Solder-Joint Pressure Fittings 2021.
- D. ASTM B32 - Standard Specification for Solder Metal 2020.
- E. ASTM B88 - Standard Specification for Seamless Copper Water Tube 2022.
- F. ASTM B88M - Standard Specification for Seamless Copper Water Tube (Metric) 2020.
- G. ASTM B813 - Standard Specification for Liquid and Paste Fluxes for Soldering of Copper and Copper Alloy Tube 2016.
- H. ASTM B828 - Standard Practice for Making Capillary Joints by Soldering of Copper and Copper Alloy Tube and Fittings 2016.
- I. AWWA C651 - Disinfecting Water Mains 2014, with Addendum (2020).
- J. NSF 61 - Drinking Water System Components - Health Effects 2022, with Errata.
- K. NSF 372 - Drinking Water System Components - Lead Content 2022.

1.4 SUBMITTALS

- A. See Section 01 3300 for submittal procedures.
- B. Product Data: Provide data on pipe materials, pipe fittings, valves, and accessories. Provide manufacturers catalog information. Indicate valve data and ratings.

1.5 QUALITY ASSURANCE

- A. Perform work in accordance with applicable codes.

1.6 DELIVERY, STORAGE, AND HANDLING

- A. Accept valves on site in shipping containers with labeling in place. Inspect for damage.
- B. Provide temporary protective coating on cast iron and steel valves.

IA DAS - FDCF Bldg A Water Heater Replacement
Project # 2142301160

- C. Provide temporary end caps and closures on piping and fittings. Maintain in place until installation.
- D. Protect piping systems from entry of foreign materials by temporary covers, completing sections of the work, and isolating parts of completed system.

PART 2 PRODUCTS

2.1 GENERAL REQUIREMENTS

- A. Potable Water Supply Systems: Provide piping, pipe fittings, and solder and flux (if used), that comply with NSF 61 and NSF 372 for maximum lead content; label pipe and fittings.

2.2 DOMESTIC WATER PIPING, ABOVE GRADE

- A. Copper Tube: ASTM B88 (ASTM B88M), Type K (A), Drawn (H).
 - 1. Fittings: ASME B16.18, cast copper alloy or ASME B16.22, wrought copper and bronze.
 - 2. Joints: ASTM B32, alloy Sn95 solder.
 - 3. Mechanical Press Sealed Fittings: Double pressed type, NSF 61 and NSF 372 approved or certified, utilizing EPDM, nontoxic synthetic rubber sealing elements.

2.3 RELIEF VALVES

- A. Pressure:
 - 1. ANSI Z21.22, AGA certified, bronze body, teflon seat, steel stem and springs, automatic, direct pressure actuated.

2.4 STRAINERS

- A. Manufacturers:
 - 1. Armstrong International, Inc: www.armstronginternational.com/#sle.
 - 2. Green Country Filter Manufacturing: www.greencountryfilter.com/#sle.
 - 3. WEAMCO: www.weamco.com/#sle.
 - 4. Engineer Pre-Approved Equivalent.
- B. Size 2 inch (50 mm) and Under:
 - 1. Threaded brass body for 175 psi (1200 kPa) CWP, Y pattern with 1/32 inch (0.8 mm) stainless steel perforated screen.
 - 2. Class 150, threaded bronze body 300 psi (2070 kPa) CWP, Y pattern with 1/32 inch (0.8 mm) stainless steel perforated screen.

PART 3 EXECUTION

3.1 PREPARATION

- A. Ream pipe and tube ends. Remove burrs.
- B. Remove scale and dirt, on inside and outside, before assembly.
- C. Prepare piping connections to equipment with flanges or unions.

3.2 INSTALLATION

- A. Install in accordance with manufacturer's instructions.
- B. Provide non-conducting dielectric connections wherever jointing dissimilar metals.
- C. Route piping in orderly manner and maintain gradient. Route parallel and perpendicular to walls.
- D. Install piping to maintain headroom, conserve space, and not interfere with use of space.
- E. Group piping whenever practical at common elevations.
- F. Provide clearance in hangers and from structure and other equipment for installation of insulation and access to valves and fittings.
- G. Install valves with stems upright or horizontal, not inverted. Refer to Section 22 0523.
- H. Copper Pipe and Tube: Make soldered joints in accordance with ASTM B828, using specified solder, and flux meeting ASTM B813; in potable water systems use flux also complying with NSF 61 and NSF 372.
- I. Pipe Hangers and Supports:
 - 1. Place hangers within 12 inches (300 mm) of each horizontal elbow.
 - 2. Provide copper plated hangers and supports for copper piping.
- J. When installing more than one piping system material, ensure system components are compatible and joined to ensure the integrity of the system. Provide necessary joining fittings. Ensure flanges, union, and couplings for servicing are consistently provided.

3.3 APPLICATION

- A. Install unions downstream of valves and at equipment or apparatus connections.
- B. Install brass male adapters each side of valves in copper piped system. Solder adapters to pipe.
- C. Install ball valves for shut-off and to isolate equipment, part of systems, or vertical risers.
- D. Provide spring loaded check valves on discharge of water pumps.
- E. Provide flow controls in water recirculating systems where indicated.

3.4 TOLERANCES

- A. Water Piping: Slope at minimum of 1/32 inch per foot (1:400) and arrange to drain at low points.

3.5 DISINFECTION OF DOMESTIC WATER PIPING SYSTEM

- A. Prior to starting work, verify system is complete, flushed and clean.
- B. Ensure acidity (pH) of water to be treated is between 7.4 and 7.6 by adding alkali (caustic soda or soda ash) or acid (hydrochloric).
- C. Inject disinfectant, free chlorine in liquid, powder, tablet or gas form, throughout system to obtain 50 to 80 mg/L residual.
- D. Bleed water from outlets to ensure distribution and test for disinfectant residual at minimum 15 percent of outlets.
- E. Maintain disinfectant in system for 24 hours.

IA DAS - FDCF Bldg A Water Heater Replacement
Project # 2142301160

- F. If final disinfectant residual tests less than 25 mg/L, repeat treatment.
- G. Flush disinfectant from system until residual equal to that of incoming water or 1.0 mg/L.
- H. Take samples no sooner than 24 hours after flushing, from 10 percent of outlets and from water entry, and analyze in accordance with AWWA C651.

END OF SECTION

**SECTION 22 1119
DOMESTIC WATER PIPING SPECIALTIES**

PART 1 GENERAL

1.1 SECTION INCLUDES

- A. Provide materials, equipment, labor, and supervision necessary to install water supply system as required by the Drawings and this Section.

1.2 CODES AND STANDARDS

- A. ASSE 1011 - Hose Connection Vacuum Breakers.
- B. ASSE 1012 - Performance Requirements for Backflow Preventer with Intermediate Atmospheric Vent.
- C. ASSE 1013 - Performance Requirements for Reduced Pressure Principle Backflow Preventers and Reduced Pressure Fire Protection Principal Backflow Preventers.
- D. ASSE 1019 - Vacuum Breaker Wall Hydrants, Freeze Resistant Automatic Draining Type.
- E. ASSE 1048 - Performance Requirements for Double Check Detector Fire Protection Backflow Assemblies.
- F. ASSE 1052 - Performance Requirements for Hose Connection Backflow Preventers.
- G. ANSI / AWWA, C700
- H. The Plumbing and Drainage Institute - PDI Standard WH 201 for Water Hammer Arrestors
- I. Uniform Plumbing Code.
- J. NFPA Codes and Standards
- K. University of Southern California Foundation for Cross-Connection Control and Hydraulic Research - USCFCCC.
- L. Lead Free: Refers to the wetted surface of pipe, fittings and fixtures in potable water systems that have a weighted average lead content =0.25% per Safe Drinking Water Act as amended January 4, 2011, Section 1417.
- M. NSF Compliance: NSF/ANSI 61 and/or NSF/ANSI 372 for valve materials for potable-water service. Valves for domestic water must be 3rd Party Certified.

1.3 SUBMITTALS

- A. Product data: Submit manufacturer's specifications and/or catalog data including material and pressure test certifications for all equipment herein.

PART 2 PRODUCTS

2.1 GENERAL

- A. Provide piping materials and factory-fabricated piping products of sizes, types, pressure ratings, and capacities as indicated. Where not indicated, provide proper selection as determined by Installer to comply with installation requirements. Provide sizes and types matching piping and equipment connections; provide fittings of materials that match pipe materials used in water supply systems. Where more than one type of material or product are indicated, selection is Installer's option.

2.2 CALIBRATED BALANCE VALVE (GLOBE TYPE) WITH FLOW METER FITTINGS

- A. Provide as indicated, calibrated balance valves equipped with two metering/test ports with internal check valves and protective caps to facilitate connecting to differential pressure meter to balance valves.
- B. Valve shall be globe style and shall provide precise flow measurement, precision flow balancing and positive shut-off with no drip seat. Valve shall be leak tight at full rated pressure.
- C. Valves shall have memory stop feature to allow valve to be closed for service and then re-opened to set point without disturbing balance position. Provide calibrated nameplate or division ring scale to indicate valve position.
- D. Valve need not be line size, but shall be sized for specific application.
- E. Provide balance valves designed for low flow applications for flows of 1 GPM and lower.
- F. Valves ½" through 2" shall be constructed of dezincification resistant brass or bronze alloy.
- G. Manufacturer: Subject to compliance with requirements, provide calibrated balance valves by Nibco, Armstrong, Grinnell, or an engineer-approved equivalent.

END OF SECTION

**SECTION 22 3000
PLUMBING EQUIPMENT**

PART 1 GENERAL

1.1 SECTION INCLUDES

- A. Domestic water heat exchangers.
- B. Domestic hot water storage tanks.
- C. Diaphragm-type compression tanks.
- D. In-line circulator pumps.

1.2 REFERENCE STANDARDS

- A. ASME BPVC-VIII-1 - Boiler and Pressure Vessel Code, Section VIII, Division 1: Rules for Construction of Pressure Vessels 2021.
- B. ICC (IPC) - International Plumbing Code Most Recent Edition Adopted by Authority Having Jurisdiction, Including All Applicable Amendments and Supplements.
- C. UL 1453 - Standard for Electric Booster and Commercial Storage Tank Water Heaters Current Edition, Including All Revisions.

1.3 SUBMITTALS

- A. See Section 01 3300, for submittals procedures.
- B. Product Data:
 - 1. Indicate pump type, capacity, power requirements.
- C. Shop Drawings:
 - 1. Indicate heat exchanger dimensions, size of tapings, and performance data.
 - 2. Indicate dimensions of tanks, tank lining methods, anchors, attachments, lifting points, tapings, and drains.
- D. Project Record Documents: Record actual locations of components.
- E. Operation and Maintenance Data: Include operation, maintenance, and inspection data, replacement part numbers and availability, and service depot location and telephone number.
- F. Warranty Documentation: Submit manufacturer warranty and ensure that forms have been completed in Owner's name and registered with manufacturer.
- G. Maintenance Materials: Furnish the following for Owner's use in maintenance of project.
 - 1. Extra Pump Seals: One of each type and size.

1.4 QUALITY ASSURANCE

- A. Certifications:
 - 1. Lead Content: Use low lead under 0.25% content of total system or lead free materials of construction for surfaces that are in contact with domestic water.
 - 2. Water Tanks: ASME labeled to ASME BPVC-VIII-1.

IA DAS - FDCF Bldg A Water Heater Replacement
Project # 2142301160

3. Products Requiring Electrical Connection: Listed and classified by Underwriters Laboratories Inc., as suitable for the purpose specified and indicated.
- B. Identification: Provide pumps with manufacturer's name, model number, and rating/capacity identified by permanently attached label.
- C. Performance: Ensure pumps operate at specified system fluid temperatures without vapor binding and cavitation, are non-overloading in parallel or individual operation, operate within 25 percent of midpoint of published maximum efficiency curve.

1.5 WARRANTY

- A. See Section 01 7700, for additional warranty requirements.
- B. Provide one year manufacturer warranty for in-line circulator and heat exchangers.
- C. Storage Tank: 25-year coverage (15 years full, 10 years prorated) for manufacturing or material defects, leaks, the production of rusty water and or chloride stress corrosion cracking. Tank warranty does not require inspection and maintenance of anode rods.

PART 2 PRODUCTS

2.1 DOMESTIC WATER HEAT EXCHANGERS

- A. Manufacturers:
 1. Armstrong Fluid Technology: www.armstrongfluidtechnology.com/#sle.
 2. Bell & Gossett, a xylem brand: www.bellgossett.com/#sle.
 3. Danfoss
 4. Engineer Pre-Approved Equivalent
- B. Type: Double wall type that separates the potable water from the heat transfer medium with a space vented to the atmosphere in accordance with ICC IPC.
- C. Assembly of heat-exchanger plates, permanently brazed together, for using heating hot water to heat domestic water.
- D. Working-Pressure Rating: Packaged heater shall be rated for 150 psig minimum at 250°F.
- E. Plate Material: 316L Stainless steel plates.
- F. Plate Thickness: Not less than 0.024 inch (0.6 mm) combined.
- G. Brazing Filler Metal: Copper.
- H. AHRI 400: Use heat exchanger certified by AHRI Liquid to Liquid Brazed and Fusion Bonded Plate Heat Exchangers (LLBF) certification program, based on AHRI Standard 400. AHRI 400: Use heat exchanger certified based on AHRI Standard 400.

2.2 DOMESTIC HOT WATER STORAGE TANKS

- A. Manufacturers:
 1. PVI.
 2. Engineer Pre-Approved Equivalent.

- B. Flow Pattern: Standard-flow arrangement, with water from bottom of storage tank circulated across heat-exchanger plates and returned to tank. Include hot-water outlet located at top of tank and temperature sensitive switch in tank. Counter flow arrangement through each heat exchanger for efficient heat transfer.
- C. Configuration: As noted on drawings.
- D. All tank connections/ fittings shall be nonferrous. Tank design shall include a manway sized access to the tank interior.
- E. The storage tank shall be ASME HLW stamped and National Board Registered for a maximum allowable working pressure of 150 psi and pressure tested at 1-1/2 times working pressure.
- F. The storage tank shall be an unlined pressure vessel constructed from phase-balanced austenitic and ferritic duplex steel with a chemical structure containing a minimum of 21% chromium to prevent corrosion and mill certified per ASTM A 923 Methods A to ensure that the product is free of detrimental chemical precipitation that affects corrosion resistance. The material selected shall be tested and certified to pass stress chloride cracking test protocols as defined in ISO 3651-2 and ASTM G123 - 00(2005) "Standard Test Method for Evaluating Stress-Corrosion Cracking of Stainless Alloys with Different Nickel Content in Boiling Acidified Sodium Chloride Solution."
- G. Waterside surfaces shall be welded internally utilizing joint designs to minimize volume of weld deposit and heat input. All heat affected zones (HAZ) shall be processed after welding to ensure the HAZ corrosion resistance is consistent with the mill condition base metal chemical composition. Weld procedures (amperage, volts, welding speed, filler metals and shielding gases) utilized shall result in a narrow range of austenite-ferrite microstructure content consistent with phase balanced objectives for welds, HAZ and the base metal.
- H. Materials shall meet ASME Section II material requirements and be accepted by NSF 61 for municipal potable water systems. Storage tank materials shall contain more than 80% postconsumer recycled materials and be 100% recyclable.
- I. Water contacting tank surfaces will be non-porous and exhibit 0% water absorption.
- J. Lined or plated storage tanks will not be acceptable.
- K. The storage tank will not require anodes of any type and none will be used.
- L. All internal and external tank surfaces shall undergo full immersion passivation and pickling processing to meet critical temperature, duration and chemical concentration controls required to complete corrosion resistance restoration of pressure vessel surfaces. Other passivation and pickling methods are not accepted. Immersion passivation and pickling certification documents are required and shall be provided with each product.
- M. Insulation: Complying with ASHRAE/IESNA 90.1, unless otherwise indicated, and suitable for operating temperature. Surround entire storage tank and nozzle except connections and controls.
- N. Dispersion Tubes: installed on both cold and hot water inlet to prevent mixing of hot and cold water inside the tank.
- O. Accessories: Tank drain, water inlet and outlet, thermometer range of 40 to 200 degrees F (4 to 93 degrees C), ASME pressure relief valve suitable for maximum working pressure.

2.3 DIAPHRAGM-TYPE COMPRESSION TANKS

- A. Manufacturers:
 - 1. Amtrol Inc: www.amtrol.com/#sle.
 - 2. Bell & Gossett, a xylem brand: www.bellgossett.com/#sle.

**IA DAS - FDCF Bldg A Water Heater Replacement
Project # 2142301160**

3. Taco, Inc: www.taco-hvac.com/#sle.
 4. Engineer Pre-Approved Equivalent.
- B. Construction: Welded steel, tested and stamped in accordance with ASME BPVC-VIII-1; supplied with National Board Form U-1, rated for working pressure of 125 psig (860 kPa), with flexible EPDM diaphragm sealed into tank, and steel legs or saddles.
- C. Accessories: Pressure gage and air-charging fitting, tank drain.

2.4 IN-LINE CIRCULATOR PUMPS

- A. Manufacturers:
1. Armstrong Fluid Technology: www.armstrongfluidtechnology.com/#sle.
 2. Bell & Gossett, a xylem brand: www.bellgossett.com/#sle.
 3. Grundfos.
 4. Taco.
 5. Engineer Pre-Approved Equivalent.
- B. The pumps shall be a wet rotor inline pump, in cast iron or lead-free stainless-steel body construction specifically designed for quiet operation. Suitable standard operations at 230° F and 175 PSIG working pressure. The pump internals shall be capable of being serviced without disturbing piping connections.
- C. The pump internals shall be capable of being serviced without disturbing piping connections.
- D. Pump shall be equipped with a water-tight seal to prevent leakage.
- E. Pump volute shall be of a cast iron design for heating systems or lead-free stainless steel for domestic water systems. The connection style on the cast iron and stainless-steel pumps shall be flanged.
- F. Motor shall be a synchronous, permanent-magnet (PM) motor or ECM and tested with the pump as one unit.

PART 3 EXECUTION

3.1 INSTALLATION

- A. Install plumbing equipment in accordance with manufacturer's instructions, as required by code, and complying with conditions of certification, if any.
- B. Coordinate with plumbing piping and related electrical work to achieve operating system.
- C. Domestic Water Heat Exchangers:
1. Domestic-Water, Heat-Exchanger Mounting: Install domestic-water heat exchangers on concrete base.
 2. Install domestic-water heat exchangers level and plumb, according to layout drawings, original design, and referenced standards. Maintain manufacturer's recommended clearances. Arrange units so controls and devices needing service are accessible.
 3. Install shutoff valves on domestic-water-supply piping to heat exchangers and on domestic-hot-water outlet piping.
 4. Install shutoff valves on heating hot-water piping to heat exchangers.

5. Install combination temperature-and-pressure relief valves in water piping for domestic-water heat exchangers without storage. Extend relief-valve outlet, with drain piping same as domestic-water piping in continuous downward pitch, and discharge by positive air gap onto closest floor drain.
 6. Install thermometer on each domestic-water, heat-exchanger, inlet and outlet piping, and install thermometer on each domestic-water, heat-exchanger, heating-fluid inlet and outlet piping.
 7. Install pressure gages on domestic-water, heat-exchanger, heating-fluid piping.
 8. Where installing piping adjacent to domestic-water heat exchangers, allow space for service and maintenance of heat exchangers. Arrange piping for easy removal of domestic-water heat exchangers.
 9. Train Owner's maintenance personnel to adjust, operate, and maintain domestic-water heat exchangers.
 10. Perform tests and inspections.
 - a. Leak Test: After installation, charge system and test for leaks. Repair leaks and retest until no leaks exist.
 - b. Operational Test: After electrical circuitry has been energized, start units to confirm proper operation.
 - c. Test and adjust controls and safeties. Replace damaged and malfunctioning controls and equipment.
- D. Domestic Water Storage Tanks:
1. Clean and flush prior to delivery to site. Seal until pipe connections are made.
 2. Install temperature and pressure relief valves in top portion of storage-tank shells of domestic-water heat exchangers with domestic-water storage. Use relief valves with sensing elements that extend into shells. Extend relief-valve outlet, with drain piping same as domestic-water piping in continuous downward pitch, and discharge by positive air gap onto closest floor drain.
- E. Pumps:
1. Provide line sized isolating valve and strainer on suction and line sized soft seated check valve and balancing valve on discharge.
 2. Decrease from line size with long radius reducing elbows or reducers. Support piping adjacent to pump such that no weight is carried on pump casings. Provide supports under elbows on pump suction and discharge line sizes 4 inches (100 mm) and over.
 3. Ensure pumps operate at specified system fluid temperatures without vapor binding and cavitation, are non-overloading in parallel or individual operation, and operate within 25 percent of midpoint of published maximum efficiency curve.

END OF SECTION

This page intentionally left blank

**SECTION 23 2113
HYDRONIC PIPING**

PART 1 GENERAL

1.1 SECTION INCLUDES

- A. Hydronic system requirements.
- B. Heating water piping, above grade.
- C. Pipe hangers and supports.
- D. Unions, flanges, mechanical couplings, and dielectric connections.
- E. Valves:
 - 1. Ball valves.
 - 2. Butterfly valves.
- F. Flow controls.
- G. Fire safing.

1.2 REFERENCE STANDARDS

- A. ASME B16.3 - Malleable Iron Threaded Fittings: Classes 150 and 300 2021.
- B. ASME B16.18 - Cast Copper Alloy Solder Joint Pressure Fittings 2021.
- C. ASME B16.22 - Wrought Copper and Copper Alloy Solder-Joint Pressure Fittings 2021.
- D. ASME B31.9 - Building Services Piping 2020.
- E. ASTM A53/A53M - Standard Specification for Pipe, Steel, Black and Hot-Dipped, Zinc-Coated, Welded and Seamless 2022.
- F. ASTM A106/A106M - Standard Specification for Seamless Carbon Steel Pipe for High-Temperature Service 2019a.
- G. ASTM A234/A234M - Standard Specification for Piping Fittings of Wrought Carbon Steel and Alloy Steel for Moderate and High Temperature Service 2023.
- H. ASTM B32 - Standard Specification for Solder Metal 2020.
- I. ASTM B88 - Standard Specification for Seamless Copper Water Tube 2022.
- J. ASTM B88M - Standard Specification for Seamless Copper Water Tube (Metric) 2020.
- K. ASTM F1476 - Standard Specification for Performance of Gasketed Mechanical Couplings for Use in Piping Applications 2007 (Reapproved 2019).
- L. AWS A5.8M/A5.8 - Specification for Filler Metals for Brazing and Braze Welding 2019.
- M. AWWA C606 - Grooved and Shouldered Joints 2015.

1.3 SUBMITTALS

- A. See Section 01 3300 for submittal procedures.
- B. Product Data:
 - 1. Include data on pipe materials, pipe fittings, valves, and accessories.

- 2. Provide manufacturers catalog information.
 - C. Project Record Documents: Record actual locations of valves.
- 1.4 DELIVERY, STORAGE, AND HANDLING
- A. Accept valves on site in shipping containers with labeling in place. Inspect for damage.
 - B. Provide temporary protective coating on cast iron and steel valves.
 - C. Provide temporary end caps and closures on piping and fittings. Maintain in place until installation.
 - D. Protect piping systems from entry of foreign materials by temporary covers, completing sections of the work, and isolating parts of completed system.

PART 2 PRODUCTS

2.1 HYDRONIC SYSTEM REQUIREMENTS

- A. Comply with ASME B31.9 and applicable federal, state, and local regulations.
- B. Piping: Provide piping, fittings, hangers, and supports as required, as indicated, and as follows:
 - 1. Where more than one piping system material is specified, provide joining fittings that are compatible with piping materials and ensure that the integrity of the system is not jeopardized.
 - 2. Use non-conducting dielectric connections whenever jointing dissimilar metals.
 - 3. Grooved mechanical joints may be used in accessible locations only.
 - a. Accessible locations include those exposed on interior of building, in pipe chases, and in mechanical rooms, aboveground outdoors, and as approved by Architect/Engineer.
 - b. Grooved mechanical connections and joints comply with AWWA C606.
 - 1) Steel: Comply with ASTM A106/A106M, Grade B or ASTM A53/A53M.
 - c. Use rigid joints unless otherwise indicated.
 - 4. Provide pipe hangers and supports in accordance with ASME B31.9 or MSS SP-58 unless indicated otherwise.
- C. Pipe-to-Valve and Pipe-to-Equipment Connections: Use flanges, unions, or grooved couplings to allow disconnection of components for servicing; do not use direct welded, soldered, or threaded connections.
- D. Valves: Provide valves where indicated:
 - 1. Provide drain valves where indicated, and if not indicated, provide at least at main shut-off, low points of piping, bases of vertical risers, and at equipment. Use 3/4 inch (20 mm) gate valves with cap; pipe to nearest floor drain.
 - 2. Isolate equipment using butterfly valves with lug end flanges or grooved mechanical couplings.
 - 3. In heating water systems, butterfly valves may be used interchangeably with gate and globe valves.

2.2 HEATING WATER PIPING, ABOVE GRADE

- A. Steel Pipe: ASTM A53/A53M, Schedule 40, black, using one of the following joint types:
 - 1. Welded Joints: ASTM A234/A234M, wrought steel welding type fittings; AWS D1.1/D1.1M welded.
 - 2. Threaded Joints: ASME B16.3, malleable iron fittings.
 - 3. Grooved Joints: AWWA C606 grooved pipe, fittings of same material, and mechanical couplings.
- B. Copper Tube: ASTM B88 (ASTM B88M), Type K (A), drawn, using one of the following joint types:
 - 1. Solder Joints: ASME B16.18 cast brass/bronze or ASME B16.22 solder wrought copper fittings.
 - a. Solder: ASTM B32 lead-free solder, HB alloy (95-5 tin-antimony) or tin and silver.
 - b. Braze: AWS A5.8M/A5.8 BCuP copper/silver alloy.
 - 2. Grooved Joints: AWWA C606 grooved tube, fittings of same material, and copper-tube-dimension mechanical couplings.
 - 3. Tee Connections: Mechanically extracted collars with notched and dimpled branch tube.
 - 4. Mechanical Press Sealed Fittings: Double pressed type complying with ASME B16.22, utilizing EPDM, nontoxic synthetic rubber sealing elements.

2.3 PIPE HANGERS AND SUPPORTS

- A. Provide hangers and supports that comply with MSS SP-58.
 - 1. If type of hanger or support for a particular situation is not indicated, select appropriate type using MSS SP-58 recommendations.
 - 2. Hangers for Pipe Sizes 1/2 to 1-1/2 Inches (13 to 38 mm): Malleable iron, adjustable swivel, split ring.
 - 3. Hangers for Hot Pipe Sizes 2 to 4 Inches (50 to 100 mm): Carbon steel, adjustable, clevis.
 - 4. Multiple or Trapeze Hangers: Steel channels with welded spacers and hanger rods.
 - 5. Wall Support for Pipe Sizes to 3 Inches (76 mm): Cast iron hook.
 - 6. Vertical Support: Steel riser clamp.
 - 7. Floor Support for Hot Pipe Sizes to 4 Inches (100 mm): Cast iron adjustable pipe saddle, lock nut, nipple, floor flange, and concrete pier or steel support.
 - 8. Hanger Rods: Mild steel threaded both ends, threaded one end, or continuous threaded.
- B. In grooved installations, use rigid couplings with offsetting angle-pattern bolt pads or with wedge-shaped grooves in header piping to permit support and hanging in accordance with ASME B31.9.

2.4 UNIONS, FLANGES, MECHANICAL COUPLINGS, AND DIELECTRIC CONNECTIONS

- A. Unions for Pipe 2 Inches (50 mm) and Less:
 - 1. Ferrous Piping: 150 psig (1034 kPa) malleable iron, threaded.
 - 2. Copper Pipe: Bronze, soldered joints.

IA DAS - FDCF Bldg A Water Heater Replacement
Project # 2142301160

- B. Flanges for Pipe 2 Inches (50 mm) and Greater:
 - 1. Ferrous Piping: 150 psig (1034 kPa) forged steel, slip-on.
 - 2. Copper Piping: Bronze.
 - 3. Gaskets: 1/16 inch (1.6 mm) thick, preformed neoprene.
- C. Mechanical Couplings for Grooved and Shouldered Joints: Two or more curved housing segments with continuous key to engage pipe groove, circular C-profile gasket, and bolts to secure and compress gasket.
 - 1. Dimensions and Testing: In accordance with AWWA C606.
 - 2. Mechanical Couplings: Comply with ASTM F1476.
 - 3. Gasket Material: EPDM suitable for operating temperature range from minus 30 degrees F (minus 34 degrees C) to 230 degrees F (110 degrees C).
 - 4. Bolts and Nuts: Hot dipped galvanized or zinc-electroplated steel.
 - 5. When pipe is field grooved, provide coupling manufacturer's grooving tools.

2.5 BALL VALVES

- A. Up To and Including 2 Inches (50 mm):
 - 1. Bronze one piece body, chrome plated brass ball, teflon seats and stuffing box ring, lever handle with balancing stops, solder ends with union.
- B. Over 2 Inches (50 mm):
 - 1. Ductile iron body, chrome plated stainless steel ball, teflon seat and stuffing box seals, lever handle or gear operated, flanged ends, rated to 800 psi (5515 kPa).

2.6 BUTTERFLY VALVES

- A. Body: Cast or ductile iron with resilient replaceable EPDM seat, wafer, lug, or grooved ends, extended neck.
- B. Disc: Construct of ductile iron with EPDM encapsulation.
- C. Operator: 10 position lever handle.

2.7 FLOW CONTROLS

- A. Manufacturers:
 - 1. Anvil International: www.anvilintl.com/#sle.
 - 2. Griswold Controls: www.griswoldcontrols.com/#sle.
 - 3. Hays Fluid Controls: www.haysfluidcontrols.com/#sle.
 - 4. ITT Bell & Gossett: www.bellgossett.com/#sle.
 - 5. Shurjoint Piping Products, Inc: www.shurjoint.com/#sle.
 - 6. Taco, Inc: www.taco-hvac.com/#sle.
 - 7. Victaulic Company: www.victaulic.com/#sle.
 - 8. Engineer Pre-Approved Equivalent.
- B. Construction: Class 125, Brass or bronze body with union on inlet and outlet, temperature and pressure test plug on inlet and outlet, blowdown/backflush drain.

- C. Calibration: Control flow within 10 percent of selected rating, over operating pressure range of 10 times minimum pressure required for control, minimum pressure 2 psi (13.7 kPa).

2.8 FIRE SAFING

- A. Metal piping and sleeves passing through floors, roof, partitions, and fire walls, shall be provided with firestop by packing space between pipe and sleeve with UL listed non-sag and self-leveling fire safing insulation per manufacturer's instructions.
- B. Plastic piping passing through fire rated floors and fire rated walls shall be provided with firestop by providing intumescent wrap strip around the pipe, enclosed in steel collar attached to structure.
- C. Cracks, Voids, or Holes Up to 4" Diameter: Use non-sag or self-leveling putty or caulking, one-piece intumescent elastomer, non-corrosive to metal, compatible with synthetic cable jackets, and capable of expanding 10 times when exposed to flame or heat, UL listed.
- D. Openings 4" or Greater: Use sealing system capable of passing 3-hour fire test in accordance with ASTM E814, consisting of wall wrap or liner, partitions, and end caps capable of expanding when exposed to temperatures of 250 to 350oF (121 to 177oC), UL listed.
- E. Seal all holes or voids made by penetrations to ensure an effective barrier against smoke, fire, toxic and combustible gases.
- F. Unless protected, from possible loading or traffic, install firestopping materials in floors having void openings or four (4) inches or more to support the same floor load requirements.
- G. Manufacturer: Subject to compliance with requirements, provide non-sag and self-leveling fire barrier caulk, wrap/strip, moldable putty, and sheet forms of one of the following:
 - 1. 3M Brand.
 - 2. Flame Stop.
 - 3. Dow Corning.
 - 4. Metacaulk.
 - 5. Engineer Pre-Approved Equivalent.

PART 3 EXECUTION

3.1 PREPARATION

- A. Ream pipe and tube ends. Remove burrs. Bevel plain end ferrous pipe.
- B. Prepare pipe for grooved mechanical joints as required by coupling manufacturer.
- C. Remove scale and dirt on inside and outside before assembly.
- D. Prepare piping connections to equipment using jointing system specified.
- E. Keep open ends of pipe free from scale and dirt. Protect open ends with temporary plugs or caps.
- F. After completion, fill, clean, and treat systems.

3.2 INSTALLATION

- A. Install in accordance with manufacturer's instructions.
- B. Route piping in orderly manner, parallel to building structure, and maintain gradient.

IA DAS - FDCF Bldg A Water Heater Replacement
Project # 2142301160

- C. Install piping to conserve building space and to avoid interference with use of space.
- D. Group piping whenever practical at common elevations.
- E. Slope piping and arrange to drain at low points.
- F. Grooved Joints:
 - 1. Install in accordance with the manufacturer's latest published installation instructions.
 - 2. Gaskets to be suitable for the intended service, molded, and produced by the coupling manufacturer.
- G. Pipe Hangers and Supports:
 - 1. Install in accordance with MSS SP-58.
 - 2. Support horizontal piping as scheduled.
 - 3. Install hangers to provide minimum 1/2-inch (13 mm) space between finished covering and adjacent work.
 - 4. Place hangers within 12 inches (300 mm) of each horizontal elbow.
 - 5. Use hangers with 1-1/2 inches (38 mm) minimum vertical adjustment. Design hangers for pipe movement without disengagement of supported pipe.
 - 6. Where several pipes can be installed in parallel and at same elevation, provide multiple or trapeze hangers.
 - 7. Provide copper plated hangers and supports for copper piping.
- H. Install valves with stems upright or horizontal, not inverted.

3.3 SCHEDULES

- A. Hanger Spacing for Copper Tubing.
 - 1. 1/2 Inch (15 mm) and 3/4 inch (20 mm): Maximum span, 5 feet (1500 mm); minimum rod size, 1/4 inch (6 mm).
 - 2. 1 Inch (25 mm): Maximum span, 6 feet (1800 mm); minimum rod size, 1/4 inch (6 mm).
 - 3. 1-1/2 Inches (40 mm) and 2 Inches (50 mm): Maximum span, 8 feet (2400 mm); minimum rod size, 3/8 inch (9 mm).
 - 4. 2-1/2 Inches (65 mm): Maximum span, 9 feet (2700 mm); minimum rod size, 3/8 inch (9 mm).
- B. Hanger Spacing for Steel Piping.
 - 1. 1/2 Inch (15 mm), 3/4 Inch (20 mm), and 1 Inch (25 mm): Maximum span, 7 feet (2100 mm); minimum rod size, 1/4 inch (6 mm).
 - 2. 1-1/4 Inches (32 mm): Maximum span, 8 feet (2400 mm); minimum rod size, 3/8 inch (9 mm).
 - 3. 1-1/2 Inches (40 mm): Maximum span, 9 feet (2700 mm); minimum rod size, 3/8 inch (9 mm).
 - 4. 2 Inches (50 mm): Maximum span, 10 feet (3.0 m); minimum rod size, 3/8 inch (9 mm).
 - 5. 2-1/2 Inches (65 mm): Maximum span, 11 feet (3.4 m); minimum rod size, 3/8 inch (9 mm).

END OF SECTION

**SECTION 26 0500
COMMON WORK RESULTS FOR ELECTRICAL**

PART 1 GENERAL

1.1 RELATED DOCUMENTS

- A. Drawings and general provisions of the Contract, including General and Supplementary Conditions and Division 01 Specification Sections, apply to this Section.

1.2 SUMMARY

- A. Section Includes:
 - 1. Electrical equipment coordination and installation.
 - 2. Sleeves for raceways and cables.
 - 3. Sleeve seals.
 - 4. Grout.

1.3 DEFINITIONS

- A. EPDM: Ethylene-propylene-diene terpolymer rubber.
- B. NBR: Acrylonitrile-butadiene rubber.

1.4 COORDINATION

- A. Coordinate arrangement, mounting, and support of electrical equipment:
 - 1. To allow maximum possible headroom unless specific mounting heights that reduce headroom are indicated.
 - 2. So connecting raceways, cables, wireways, cable trays, and busways will be clear of obstructions and of the working and access space of other equipment.
- B. Coordinate installation of required supporting devices and set sleeves in cast-in-place concrete, masonry walls, and other structural components as they are constructed.

PART 2 PRODUCTS

2.1 SLEEVES FOR RACEWAYS AND CABLES

- A. Steel Pipe Sleeves: ASTM A 53/A 53M, Type E, Grade B, Schedule 40, galvanized steel, plain ends.
- B. Cast-Iron Pipe Sleeves: Cast or fabricated "wall pipe," equivalent to ductile-iron pressure pipe, with plain ends and integral waterstop, unless otherwise indicated.
- C. Sleeves for Rectangular Openings: Galvanized sheet steel.
 - 1. Minimum Metal Thickness:
 - a. For sleeve cross-section rectangle perimeter less than 50 inches (1270 mm) and no side more than 16 inches (400 mm), thickness shall be 0.052 inch (1.3 mm).

IA DAS - FDCF Bldg A Water Heater Replacement
Project # 2142301160

- b. For sleeve cross-section rectangle perimeter equal to, or more than, 50 inches (1270 mm) and 1 or more sides equal to, or more than, 16 inches (400 mm), thickness shall be 0.138 inch (3.5 mm).

2.2 SLEEVE SEALS

- A. Description: Modular sealing device, designed for field assembly, to fill annular space between sleeve and raceway or cable.
 1. Sealing Elements: EPDM or NBR interlocking links shaped to fit surface of cable or conduit. Include type and number required for material and size of raceway or cable.
 2. Pressure Plates: Carbon steel. Include two for each sealing element.
 3. Connecting Bolts and Nuts: Carbon steel with corrosion-resistant coating of length required to secure pressure plates to sealing elements. Include one for each sealing element.

2.3 GROUT

- A. Nonmetallic, Shrinkage-Resistant Grout: ASTM C 1107, factory-packaged, nonmetallic aggregate grout, noncorrosive, nonstaining, mixed with water to consistency suitable for application and a 30-minute working time.

PART 3 EXECUTION

3.1 COMMON REQUIREMENTS FOR ELECTRICAL INSTALLATION

- A. Comply with NECA 1.
- B. Comply with applicable provisions of Occupational Safety and Health Act (OSHA), NFPA Standards and Pamphlets, NEIS Standards, and common workplace practice.
- C. Headroom Maintenance: If mounting heights or other location criteria are not indicated, arrange, and install components and equipment to provide maximum possible headroom consistent with these requirements.
- D. Equipment: Install to facilitate service, maintenance, and repair or replacement of components of both electrical equipment and other nearby installations. Connect in such a way as to facilitate future disconnecting with minimum interference with other items in the vicinity.

3.2 SLEEVE INSTALLATION FOR ELECTRICAL PENETRATIONS

- A. Electrical penetrations occur when raceways, cables, wireways, cable trays, or busways penetrate concrete slabs, concrete or masonry walls, or fire-rated floor and wall assemblies.
- B. Concrete Slabs and Walls: Install sleeves for penetrations unless core-drilled holes or formed openings are used. Install sleeves during erection of slabs and walls.
- C. Use pipe sleeves unless penetration arrangement requires rectangular sleeved opening.
- D. Fire-Rated Assemblies: Install sleeves for penetrations of fire-rated floor and wall assemblies unless openings compatible with firestop system used are fabricated during construction of floor or wall.
- E. Cut sleeves to length for mounting flush with both surfaces of walls.
- F. Extend sleeves installed in floors 2 inches (50 mm) above finished floor level.

- G. Size pipe sleeves to provide 1/4-inch (6.4-mm) annular clear space between sleeve and raceway or cable, unless indicated otherwise.
- H. Seal space outside of sleeves with grout for penetrations of concrete and masonry
 - 1. Promptly pack grout solidly between sleeve and wall so no voids remain. Tool exposed surfaces smooth; protect grout while curing.
- I. Interior Penetrations of Non-Fire-Rated Walls and Floors: Seal annular space between sleeve and raceway or cable, using joint sealant appropriate for size, depth, and location of joint.
- J. Fire-Rated-Assembly Penetrations: Maintain indicated fire rating of walls, partitions, ceilings, and floors at raceway and cable penetrations. Install sleeves and seal raceway and cable penetration sleeves with firestop materials.
- K. Aboveground, Exterior-Wall Penetrations: Seal penetrations using cast-iron pipe sleeves and mechanical sleeve seals. Select sleeve size to allow for 1-inch (25-mm) annular clear space between pipe and sleeve for installing mechanical sleeve seals.

3.3 SLEEVE-SEAL INSTALLATION

- A. Install to seal exterior wall penetrations.
- B. Use type and number of sealing elements recommended by manufacturer for raceway or cable material and size. Position raceway or cable in center of sleeve. Assemble mechanical sleeve seals and install in annular space between raceway or cable and sleeve. Tighten bolts against pressure plates that cause sealing elements to expand and make watertight seal.

3.4 FIRESTOPPING

- A. Apply firestopping to penetrations of fire-rated floor and wall assemblies for electrical installations to restore original fire-resistance rating of assembly.

END OF SECTION

This page intentionally left blank

SECTION 26 0519
LOW-VOLTAGE ELECTRICAL POWER CONDUCTORS AND CABLES

PART 1 GENERAL

1.1 SECTION INCLUDES

- A. Single conductor building wire.
- B. Wiring connectors.
- C. Electrical tape.
- D. Wire pulling lubricant.
- E. Cable ties.

1.2 RELATED REQUIREMENTS

- A. Section 26 0526 - Grounding and Bonding for Electrical Systems: Additional requirements for grounding conductors and grounding connectors.

1.3 REFERENCE STANDARDS

- A. ASTM B3 - Standard Specification for Soft or Annealed Copper Wire 2013 (Reapproved 2018).
- B. ASTM B8 - Standard Specification for Concentric-Lay-Stranded Copper Conductors, Hard, Medium-Hard, or Soft 2011 (Reapproved 2017).
- C. ASTM B33 - Standard Specification for Tin-Coated Soft or Annealed Copper Wire for Electrical Purposes 2010, with Editorial Revision (2020).
- D. ASTM B787/B787M - Standard Specification for 19 Wire Combination Unilay-Stranded Copper Conductors for Subsequent Insulation 2004 (Reapproved 2020).
- E. ASTM D3005 - Standard Specification for Low-Temperature Resistant Vinyl Chloride Plastic Pressure-Sensitive Electrical Insulating Tape 2017.
- F. NECA 1 - Standard for Good Workmanship in Electrical Construction 2015.
- G. NEMA WC 70 - Power Cables Rated 2000 Volts or Less for the Distribution of Electrical Energy 2021.
- H. NETA ATS - Standard for Acceptance Testing Specifications for Electrical Power Equipment and Systems 2021.
- I. NFPA 70 - National Electrical Code Most Recent Edition Adopted by Authority Having Jurisdiction, Including All Applicable Amendments and Supplements.
- J. UL 44 - Thermoset-Insulated Wires and Cables Current Edition, Including All Revisions.
- K. UL 83 - Thermoplastic-Insulated Wires and Cables Current Edition, Including All Revisions.
- L. UL 486A-486B - Wire Connectors Current Edition, Including All Revisions.
- M. UL 486C - Splicing Wire Connectors Current Edition, Including All Revisions.
- N. UL 486D - Sealed Wire Connector Systems Current Edition, Including All Revisions.
- O. UL 510 - Polyvinyl Chloride, Polyethylene, and Rubber Insulating Tape Current Edition, Including All Revisions.

**IA DAS - FDCF Bldg A Water Heater Replacement
Project # 2142301160**

1.4 ADMINISTRATIVE REQUIREMENTS

- A. Coordination:
1. Coordinate sizes of raceways, boxes, and equipment enclosures installed under other sections with the actual conductors to be installed, including adjustments for conductor sizes increased for voltage drop.
 2. Coordinate with electrical equipment installed under other sections to provide terminations suitable for use with the conductors to be installed.
 3. Notify Architect/Engineer of any conflicts with or deviations from the contract documents. Obtain direction before proceeding with work.

1.5 QUALITY ASSURANCE

- A. Conform to requirements of NFPA 70.
- B. Maintain at the project site a copy of each referenced document that prescribes execution requirements.
- C. Product Listing Organization Qualifications: An organization recognized by OSHA as a Nationally Recognized Testing Laboratory (NRTL) and acceptable to authorities having jurisdiction.

1.6 DELIVERY, STORAGE, AND HANDLING

- A. Receive, inspect, handle, and store conductors and cables in accordance with manufacturer's instructions.

1.7 FIELD CONDITIONS

- A. Do not install or otherwise handle thermoplastic-insulated conductors at temperatures lower than 14 degrees F (-10 degrees C), unless otherwise permitted by manufacturer's instructions. When installation below this temperature is unavoidable, notify Architect/Engineer and obtain direction before proceeding with work.

PART 2 PRODUCTS

2.1 CONDUCTOR AND CABLE APPLICATIONS

- A. Do not use conductors and cables for applications other than as permitted by NFPA 70 and product listing.
- B. Provide single conductor building wire installed in suitable raceway unless otherwise indicated, permitted, or required.
1. Exceptions:
 - a. Use manufactured wiring systems for branch circuits where concealed above accessible ceilings for lighting.
 - 1) Exception: Provide single conductor building wire in raceway for circuit homerun from distribution box to panelboard.
- C. Nonmetallic-sheathed cable is not permitted.
- D. Underground feeder and branch-circuit cable is not permitted.

2.2 CONDUCTOR AND CABLE GENERAL REQUIREMENTS

- A. Provide products that comply with requirements of NFPA 70.
- B. Provide products listed, classified, and labeled as suitable for the purpose intended.
- C. Unless specifically indicated to be excluded, provide all required conduit, boxes, wiring, connectors, etc. as required for a complete operating system.
- D. Comply with NEMA WC 70.
- E. Thermoplastic-Insulated Conductors and Cables: Listed and labeled as complying with UL 83.
- F. Thermoset-Insulated Conductors and Cables: Listed and labeled as complying with UL 44.
- G. Conductors for Grounding and Bonding: Also comply with Section 26 0526.
- H. Conductor Material:
 - 1. Provide copper conductors except where aluminum conductors are specifically indicated or permitted for substitution. Conductor sizes indicated are based on copper unless specifically indicated as aluminum. Conductors designated with the abbreviation "AL" indicate aluminum.
 - a. Substitution of aluminum conductors for copper is permitted, when approved by Owner and authority having jurisdiction, only for the following:
 - 1) Services: Copper conductors size 1/0 AWG and larger.
 - 2) Feeders: Copper conductors size 1/0 AWG and larger.
 - 2. Copper Conductors: Soft drawn annealed, 98 percent conductivity, uncoated copper conductors complying with ASTM B3, ASTM B8, or ASTM B787/B787M unless otherwise indicated.
 - 3. Tinned Copper Conductors: Comply with ASTM B33.
- I. Minimum Conductor Size:
 - 1. Branch Circuits: 12 AWG.
- J. Where conductor size is not indicated, size to comply with NFPA 70 but not less than applicable minimum size requirements specified.
- K. Conductor Color Coding:
 - 1. Color code conductors as indicated unless otherwise required by the authority having jurisdiction. Maintain consistent color coding throughout project.
 - 2. Color Coding Method: Integrally colored insulation.
 - a. Conductors size 4 AWG and larger may have black insulation color coded using vinyl color coding electrical tape.
 - 3. Color Code:
 - a. 208Y/120 V, 3 Phase, 4 Wire System:
 - 1) Phase A: Black.
 - 2) Phase B: Red.
 - 3) Phase C: Blue.
 - 4) Neutral/Grounded: White.
 - b. Equipment Ground, All Systems: Green.

2.3 SINGLE CONDUCTOR BUILDING WIRE

- A. Manufacturers:
 - 1. Copper Building Wire:
 - a. Encore Wire Corporation: www.encorewire.com/#sle.
 - b. General Cable Technologies Corporation: www.generalcable.com/#sle.
 - c. Nexans Energy USA.
 - d. The Okonite Company.
 - e. Prysmian Power Cables and Systems: www.us.prysmian.com.
 - f. Southwire Company: www.southwire.com/#sle.
 - g. Or Engineer Pre-Approved Equivalent.
- B. Description: Single conductor insulated wire.
- C. Conductor Stranding:
 - 1. Feeders and Branch Circuits:
 - a. Size 10 AWG and Smaller: Solid.
 - b. Size 8 AWG and Larger: Stranded.
- D. Insulation Voltage Rating: 600 V.
- E. Insulation:
 - 1. Copper Building Wire: Type THHN/THWN-2, except as indicated below.

2.4 WIRING CONNECTORS

- A. Description: Wiring connectors appropriate for the application, suitable for use with the conductors to be connected, and listed as complying with UL 486A-486B or UL 486C as applicable.
- B. Connectors for Grounding and Bonding: Comply with Section 26 0526.
- C. Wiring Connectors for Splices and Taps:
 - 1. Copper Conductors Size 8 AWG and Smaller: Use twist-on insulated spring connectors.
 - 2. Copper Conductors Size 6 AWG and Larger: Use mechanical connectors or compression connectors.
- D. Wiring Connectors for Terminations:
 - 1. Provide terminal lugs for connecting conductors to equipment furnished with terminations designed for terminal lugs.
 - 2. Provide compression adapters for connecting conductors to equipment furnished with mechanical lugs when only compression connectors are specified.
 - 3. Where over-sized conductors are larger than the equipment terminations can accommodate, provide connectors suitable for reducing to appropriate size, but not less than required for the rating of the overcurrent protective device.
 - 4. Copper Conductors Size 8 AWG and Larger: Use mechanical connectors or compression connectors where connectors are required.

- E. Twist-on Insulated Spring Connectors: Rated 600 V, 221 degrees F (105 degrees C) for standard applications and 302 degrees F (150 degrees C) for high temperature applications; pre-filled with sealant and listed as complying with UL 486D for damp and wet locations.
- F. Mechanical Connectors: Provide bolted type or set-screw type.
- G. Compression Connectors: Provide circumferential type or hex type crimp configuration.
- H. Crimped Terminals: Nylon-insulated, with insulation grip and terminal configuration suitable for connection to be made.

2.5 WIRING ACCESSORIES

- A. Electrical Tape:
 - 1. Vinyl Color Coding Electrical Tape: Integrally colored to match color code indicated; listed as complying with UL 510; minimum thickness of 7 mil (0.18 mm); resistant to abrasion, corrosion, and sunlight; suitable for continuous temperature environment up to 221 degrees F (105 degrees C).
 - 2. Vinyl Insulating Electrical Tape: Complying with ASTM D3005 and listed as complying with UL 510; minimum thickness of 7 mil (0.18 mm); resistant to abrasion, corrosion, and sunlight; conformable for application down to 0 degrees F (-18 degrees C) and suitable for continuous temperature environment up to 221 degrees F (105 degrees C).
- B. Wire Pulling Lubricant: Listed; suitable for use with the conductors or cables to be installed and suitable for use at the installation temperature.
- C. Cable Ties: Material and tensile strength rating suitable for application.

PART 3 EXECUTION

3.1 EXAMINATION

- A. Verify that interior of building has been protected from weather.
- B. Verify that work likely to damage wire and cable has been completed.
- C. Verify that raceways, boxes, and equipment enclosures are installed and are properly sized to accommodate conductors and cables in accordance with NFPA 70.
- D. Verify that field measurements are as indicated.
- E. Verify that conditions are satisfactory for installation prior to starting work.

3.2 PREPARATION

- A. Clean raceways thoroughly to remove foreign materials before installing conductors and cables.

3.3 INSTALLATION

- A. Circuiting Requirements:
 - 1. Unless dimensioned, circuit routing indicated is diagrammatic.
 - 2. When circuit destination is indicated without specific routing, determine exact routing required.

IA DAS - FDCF Bldg A Water Heater Replacement
Project # 2142301160

3. Include circuit lengths required to install connected devices within 10 ft (3.0 m) of location indicated.
 4. Maintain separation of Class 1, Class 2, and Class 3 remote-control, signaling, and power-limited circuits in accordance with NFPA 70.
 5. Maintain separation of wiring for emergency systems in accordance with NFPA 70.
 6. Circuiting Adjustments: Unless otherwise indicated, when branch circuits are indicated as separate, combining them together in a single raceway is permitted, under the following conditions:
 - a. Provide no more than six current-carrying conductors in a single raceway. Dedicated neutral conductors are considered current-carrying conductors.
 - b. Increase size of conductors as required to account for ampacity derating.
 - c. Size raceways, boxes, etc. to accommodate conductors.
 7. Common Neutrals: Unless otherwise indicated, sharing of neutral/grounded conductors among up to three single phase branch circuits of different phases installed in the same raceway is not permitted. Provide dedicated neutral/grounded conductor for each individual branch circuit.
- B. Install products in accordance with manufacturer's instructions.
- C. Perform work in accordance with NECA 1 (general workmanship).
- D. Installation in Raceway:
1. Tape ends of conductors and cables to prevent infiltration of moisture and other contaminants.
 2. Pull all conductors and cables together into raceway at same time.
 3. Do not damage conductors and cables or exceed manufacturer's recommended maximum pulling tension and sidewall pressure.
 4. Use suitable wire pulling lubricant where necessary, except when lubricant is not recommended by the manufacturer.
- E. Paralleled Conductors: Install conductors of the same length and terminate in the same manner.
- F. Secure and support conductors and cables in accordance with NFPA 70 using suitable supports and methods approved by the authority having jurisdiction. Provide independent support from building structure. Do not provide support from raceways, piping, ductwork, or other systems.
1. Installation Above Suspended Ceilings: Do not provide support from ceiling support system. Do not provide support from ceiling grid or allow conductors and cables to lay on ceiling tiles.
- G. Terminate cables using suitable fittings.
- H. Install conductors with a minimum of 12 inches (300 mm) of slack at each outlet.
- I. Neatly train and bundle conductors inside boxes, wireways, panelboards and other equipment enclosures.
- J. Group or otherwise identify neutral/grounded conductors with associated ungrounded conductors inside enclosures in accordance with NFPA 70.

- K. Make wiring connections using specified wiring connectors.
 - 1. Make splices and taps only in accessible boxes. Do not pull splices into raceways or make splices in conduit bodies or wiring gutters.
 - 2. Remove appropriate amount of conductor insulation for making connections without cutting, nicking, or damaging conductors.
 - 3. Do not remove conductor strands to facilitate insertion into connector.
 - 4. Clean contact surfaces on conductors and connectors to suitable remove corrosion, oxides, and other contaminants. Do not use wire brush on plated connector surfaces.
 - 5. Mechanical Connectors: Secure connections according to manufacturer's recommended torque settings.
 - 6. Compression Connectors: Secure connections using manufacturer's recommended tools and dies.
- L. Insulate splices and taps that are made with uninsulated connectors using methods suitable for the application, with insulation and mechanical strength at least equivalent to unspliced conductors.
- M. Insulate ends of spare conductors using vinyl insulating electrical tape.
- N. Field-Applied Color Coding: Where vinyl color coding electrical tape is used in lieu of integrally colored insulation as permitted in Part 2 under "Color Coding", apply half overlapping turns of tape at each termination and at each location conductors are accessible.
- O. Fire Safing
 - 1. Metal piping and sleeves passing through floors, roof, partitions and fire walls, shall be provided with firestop by packing space between pipe and sleeve with UL listed non-sag and self-leveling fire safing insulation per manufacturer's instructions.
 - 2. Plastic piping passing through fire rated floors and fire rated walls shall be provided with firestop by providing intumescent wrap strip around the pipe, enclosed in steel collar attached to structure.
 - 3. Cracks, Voids, or Holes Up to 4" Diameter: Use non-sag or self-leveling putty or caulking, one-piece intumescent elastomer, non-corrosive to metal, compatible with synthetic cable jackets, and capable of expanding 10 times when exposed to flame or heat, UL listed.
 - 4. Seal all holes or voids made by penetrations to ensure an effective barrier against smoke, fire, toxic and combustible gases.
 - 5. Unless protected, from possible loading or traffic, install firestopping materials in floors having void openings or four (4) inches or more to support the same floor load requirements.
 - 6. Manufacturer: Subject to compliance with requirements, provide non-sag and self-leveling fire barrier caulk, wrap/strip, moldable putty, and sheet forms of one of the following:
 - a. 3M Brand.
 - b. Flame Stop.
 - c. Dow Corning.
 - d. Metacaulk.
 - e. Engineer Pre-Approved Equivalent.

IA DAS - FDCF Bldg A Water Heater Replacement
Project # 2142301160

- P. Unless specifically indicated to be excluded, provide final connections to all equipment and devices, including those furnished by others, as required for a complete operating system.

3.4 FIELD QUALITY CONTROL

- A. Inspect and test in accordance with NETA ATS, except Section 4.
- B. Perform inspections and tests listed in NETA ATS, Section 7.3.2. The insulation resistance test is required for all conductors. The resistance test for parallel conductors listed as optional is not required.
- C. Correct deficiencies and replace damaged or defective conductors and cables.

END OF SECTION

**SECTION 26 0526
GROUNDING AND BONDING FOR ELECTRICAL SYSTEMS**

PART 1 GENERAL

1.1 SECTION INCLUDES

- A. Grounding and bonding requirements.
- B. Conductors for grounding and bonding.
- C. Connectors for grounding and bonding.
- D. Ground bars.
- E. Ground access wells.

1.2 RELATED REQUIREMENTS

- A. Section 26 0519 - Low-Voltage Electrical Power Conductors and Cables: Additional requirements for conductors for grounding and bonding, including conductor color coding.

1.3 REFERENCE STANDARDS

- A. IEEE 81 - IEEE Guide for Measuring Earth Resistivity, Ground Impedance, and Earth Surface Potentials of a Grounding System 2012.
- B. NECA 1 - Standard for Good Workmanship in Electrical Construction 2015.
- C. NETA ATS - Standard for Acceptance Testing Specifications for Electrical Power Equipment and Systems 2021.
- D. NFPA 70 - National Electrical Code Most Recent Edition Adopted by Authority Having Jurisdiction, Including All Applicable Amendments and Supplements.
- E. UL 467 - Grounding and Bonding Equipment Current Edition, Including All Revisions.

1.4 ADMINISTRATIVE REQUIREMENTS

- A. Coordination:
 - 1. Verify exact locations of underground metal water service pipe entrances to building.
 - 2. Coordinate the work with other trades to provide steel reinforcement complying with specified requirements for concrete-encased electrode.
 - 3. Notify Architect/Engineer of any conflicts with or deviations from the contract documents. Obtain direction before proceeding with work.
- B. Sequencing:
 - 1. Do not install ground rod electrodes until final backfill and compaction is complete.

1.5 QUALITY ASSURANCE

- A. Conform to requirements of NFPA 70.
- B. Maintain at the project site a copy of each referenced document that prescribes execution requirements.

- C. Product Listing Organization Qualifications: An organization recognized by OSHA as a Nationally Recognized Testing Laboratory (NRTL) and acceptable to authorities having jurisdiction.

1.6 DELIVERY, STORAGE, AND HANDLING

- A. Receive, inspect, handle, and store products in accordance with manufacturer's instructions.

PART 2 PRODUCTS

2.1 GROUNDING AND BONDING REQUIREMENTS

- A. Do not use products for applications other than as permitted by NFPA 70 and product listing.
- B. Unless specifically indicated to be excluded, provide all required components, conductors, connectors, conduit, boxes, fittings, supports, accessories, etc. as necessary for a complete grounding and bonding system.
- C. Where conductor size is not indicated, size to comply with NFPA 70 but not less than applicable minimum size requirements specified.
- D. Bonding and Equipment Grounding:
 - 1. Provide bonding for equipment grounding conductors, equipment ground busses, metallic equipment enclosures, metallic raceways and boxes, device grounding terminals, and other normally non-current-carrying conductive materials enclosing electrical conductors/equipment or likely to become energized as indicated and in accordance with NFPA 70.
 - 2. Provide insulated equipment grounding conductor in each feeder and branch circuit raceway. Do not use raceways as sole equipment grounding conductor.
 - 3. Where circuit conductor sizes are increased for voltage drop, increase size of equipment grounding conductor proportionally in accordance with NFPA 70.
 - 4. Unless otherwise indicated, connect wiring device grounding terminal to branch circuit equipment grounding conductor and to outlet box with bonding jumper.
 - 5. Terminate branch circuit equipment grounding conductors on solidly bonded equipment ground bus only. Do not terminate on neutral (grounded) or isolated/insulated ground bus.
 - 6. Provide bonding jumper across expansion or expansion/deflection fittings provided to accommodate conduit movement.
 - 7. Provide bonding for interior metal piping systems in accordance with NFPA 70. This includes, but is not limited to:
 - a. Metal water piping where not already effectively bonded to metal underground water pipe used as grounding electrode.
 - 8. Provide bonding for interior metal air ducts.
 - 9. Provide bonding for metal building frame.

2.2 GROUNDING AND BONDING COMPONENTS

- A. General Requirements:
 - 1. Provide products listed, classified, and labeled as suitable for the purpose intended.
 - 2. Provide products listed and labeled as complying with UL 467 where applicable.

- B. Conductors for Grounding and Bonding, in Addition to Requirements of Section 26 0526:
 - 1. Use insulated copper conductors unless otherwise indicated.
 - a. Exceptions:
 - 1) Use bare copper conductors where installed underground in direct contact with earth.
 - 2) Use bare copper conductors where directly encased in concrete (not in raceway).
- C. Connectors for Grounding and Bonding:
 - 1. Description: Connectors appropriate for the application and suitable for the conductors and items to be connected; listed and labeled as complying with UL 467.
 - 2. Unless otherwise indicated, use exothermic welded connections or compression connectors for underground, concealed and other inaccessible connections.
 - a. Exceptions:
 - 1) Use mechanical connectors for connections to electrodes at ground access wells.
 - 3. Unless otherwise indicated, use mechanical connectors, compression connectors, or exothermic welded connections for accessible connections.
 - a. Exceptions:
 - 1) Use exothermic welded connections for connections to metal building frame.

PART 3 EXECUTION

3.1 EXAMINATION

- A. Verify that work likely to damage grounding and bonding system components has been completed.
- B. Verify that field measurements are as indicated.
- C. Verify that conditions are satisfactory for installation prior to starting work.

3.2 INSTALLATION

- A. Install products in accordance with manufacturer's instructions.
- B. Perform work in accordance with NECA 1 (general workmanship).
- C. Make grounding and bonding connections using specified connectors.
 - 1. Remove appropriate amount of conductor insulation for making connections without cutting, nicking, or damaging conductors. Do not remove conductor strands to facilitate insertion into connector.
 - 2. Remove nonconductive paint, enamel, or similar coating at threads, contact points, and contact surfaces.
 - 3. Exothermic Welds: Make connections using molds and weld material suitable for the items to be connected in accordance with manufacturer's recommendations.
 - 4. Mechanical Connectors: Secure connections according to manufacturer's recommended torque settings.

IA DAS - FDCF Bldg A Water Heater Replacement
Project # 2142301160

- 5. Compression Connectors: Secure connections using manufacturer's recommended tools and dies.
- D. Identify grounding and bonding system components in accordance with Section 26 0553.

3.3 FIELD QUALITY CONTROL

- A. Inspect and test in accordance with NETA ATS except Section 4.
- B. Perform inspections and tests listed in NETA ATS, Section 7.13.
- C. Perform ground electrode resistance tests under normally dry conditions. Precipitation within the previous 48 hours does not constitute normally dry conditions.
- D. Investigate and correct deficiencies where measured ground resistances do not comply with specified requirements.
- E. Submit detailed reports indicating inspection and testing results and corrective actions taken.

END OF SECTION

**SECTION 26 0529
HANGERS AND SUPPORTS FOR ELECTRICAL SYSTEMS**

PART 1 GENERAL

1.1 SECTION INCLUDES

- A. Support and attachment requirements and components for equipment, conduit, cable, boxes, and other electrical work.

1.2 RELATED REQUIREMENTS

- A. Section 26 0533.13 - Conduit for Electrical Systems: Additional support and attachment requirements for conduits.

1.3 REFERENCE STANDARDS

- A. ASTM A123/A123M - Standard Specification for Zinc (Hot-Dip Galvanized) Coatings on Iron and Steel Products 2017.
- B. ASTM A153/A153M - Standard Specification for Zinc Coating (Hot-Dip) on Iron and Steel Hardware 2016a.
- C. ASTM B633 - Standard Specification for Electrodeposited Coatings of Zinc on Iron and Steel 2023.
- D. MFMA-4 - Metal Framing Standards Publication 2004.
- E. NECA 1 - Standard for Good Workmanship in Electrical Construction 2015.
- F. NFPA 70 - National Electrical Code Most Recent Edition Adopted by Authority Having Jurisdiction, Including All Applicable Amendments and Supplements.
- G. UL 5B - Strut-Type Channel Raceways and Fittings Current Edition, Including All Revisions.

1.4 ADMINISTRATIVE REQUIREMENTS

- A. Coordination:
 - 1. Coordinate sizes and arrangement of supports and bases with the actual equipment and components to be installed.
 - 2. Coordinate the work with other trades to provide additional framing and materials required for installation.
 - 3. Coordinate compatibility of support and attachment components with mounting surfaces at the installed locations.
 - 4. Coordinate the arrangement of supports with ductwork, piping, equipment and other potential conflicts installed under other sections or by others.
 - 5. Notify Architect/Engineer of any conflicts with or deviations from the contract documents. Obtain direction before proceeding with work.

1.5 QUALITY ASSURANCE

- A. Comply with NFPA 70.
- B. Comply with applicable building code.

IA DAS - FDCF Bldg A Water Heater Replacement
Project # 2142301160

- C. Design equipment supports capable of supporting combined operating weight of supported equipment and connected systems and components.
- D. Rated Strength: Adequate in tension, shear, and pullout force to resist maximum loads calculated or imposed for this Project, with a minimum structural safety factor of four times the applied force.
- E. Product Listing Organization Qualifications: An organization recognized by OSHA as a Nationally Recognized Testing Laboratory (NRTL) and acceptable to authorities having jurisdiction.
- F. Welding: Qualify procedures and personnel according to AWS D1.1/D1.1M, "Structural Welding Code - Steel."

1.6 DELIVERY, STORAGE, AND HANDLING

- A. Receive, inspect, handle, and store products in accordance with manufacturer's instructions.

PART 2 PRODUCTS

2.1 SUPPORT AND ATTACHMENT COMPONENTS

- A. General Requirements:
 - 1. Provide all required hangers, supports, anchors, fasteners, fittings, accessories, and hardware as necessary for the complete installation of electrical work.
 - 2. Provide products listed, classified, and labeled as suitable for the purpose intended, where applicable.
 - 3. Where support and attachment component types and sizes are not indicated, select in accordance with manufacturer's application criteria as required for the load to be supported with a minimum safety factor of 2.5. Include consideration for vibration, equipment operation, and shock loads where applicable.
 - 4. Do not use products for applications other than as permitted by NFPA 70 and product listing.
 - 5. Steel Components: Use corrosion resistant materials suitable for the environment where installed.
 - a. Indoor Dry Locations: Use zinc-plated steel or approved equivalent unless otherwise indicated.
 - b. Outdoor and Damp or Wet Indoor Locations: Use galvanized steel, stainless steel, or approved equivalent unless otherwise indicated.
 - c. Zinc-Plated Steel: Electroplated in accordance with ASTM B633.
 - d. Galvanized Steel: Hot-dip galvanized after fabrication in accordance with ASTM A123/A123M or ASTM A153/A153M.
- B. Conduit and Cable Supports: Straps, clamps, etc. suitable for the conduit or cable to be supported.
 - 1. Conduit Straps: One-hole or two-hole type; steel or malleable iron.
 - 2. Conduit Clamps: Bolted type unless otherwise indicated.

- C. Raceway and Cable Supports: As described in NECA 1 and NECA 101.
- D. Outlet Box Supports: Hangers, brackets, etc. suitable for the boxes to be supported.
- E. Metal Channel (Strut) Framing Systems: Factory-fabricated continuous-slot metal channel (strut) and associated fittings, accessories, and hardware required for field-assembly of supports.
 - 1. Comply with MFMA-4.
 - 2. Channel (Strut) Used as Raceway (only where specifically indicated): Listed and labeled as complying with UL 5B.
 - 3. Minimum Channel Thickness: Steel sheet, 12 gage, 0.1046 inch (2.66 mm).
 - 4. Minimum Channel Dimensions: 1-5/8 inch (41 mm) width by 13/16 inch (21 mm) height.
- F. Hanger Rods: Threaded zinc-plated steel unless otherwise indicated.
 - 1. Minimum Size, Unless Otherwise Indicated or Required:
 - a. Equipment Supports: 1/2 inch (13 mm) diameter.
 - b. Busway Supports: 1/2 inch (13 mm) diameter.
 - c. Single Conduit up to 1 inch (27 mm) trade size: 1/4 inch (6 mm) diameter.
 - d. Single Conduit larger than 1 inch (27 mm) trade size: 3/8 inch (10 mm) diameter.
 - e. Trapeze Support for Multiple Conduits: 3/8 inch (10 mm) diameter.
 - f. Outlet Boxes: 1/4 inch (6 mm) diameter.
 - g. Luminaires: 1/4 inch (6 mm) diameter.
- G. Anchors and Fasteners:
 - 1. Unless otherwise indicated and where not otherwise restricted, use the anchor and fastener types indicated for the specified applications.
 - 2. Concrete: Use preset concrete inserts, expansion anchors, or screw anchors.
 - 3. Solid or Grout-Filled Masonry: Use expansion anchors or screw anchors.
 - 4. Hollow Masonry: Use toggle bolts.
 - 5. Hollow Stud Walls: Use toggle bolts.
 - 6. Steel: Use beam clamps, machine bolts, or welded threaded studs.
 - 7. Sheet Metal: Use sheet metal screws.
 - 8. Wood: Use wood screws.
 - 9. Plastic and lead anchors are not permitted.
 - 10. Powder-actuated fasteners are not permitted.
 - 11. Preset Concrete Inserts: Continuous metal channel (strut) and spot inserts specifically designed to be cast in concrete ceilings, walls, and floors.
 - a. Comply with MFMA-4.
 - b. Channel Material: Use galvanized steel.
 - c. Manufacturer: Same as manufacturer of metal channel (strut) framing system or Engineer Pre-Approved Equivalent.

PART 3 EXECUTION

3.1 EXAMINATION

- A. Verify that field measurements are as indicated.
- B. Verify that mounting surfaces are ready to receive support and attachment components.
- C. Verify that conditions are satisfactory for installation prior to starting work.

3.2 INSTALLATION

- A. Install products in accordance with manufacturer's instructions.
- B. Perform work in accordance with NECA 1 (general workmanship).
- C. Install anchors and fasteners in accordance with ICC Evaluation Services, LLC (ICC-ES) evaluation report conditions of use where applicable.
- D. Provide independent support from building structure. Do not provide support from piping, ductwork, or other systems.
- E. Install support and attachment components for steel conduits in accordance with NECA 101
- F. Unless specifically indicated or approved by Architect/Engineer, do not provide support from suspended ceiling support system or ceiling grid.
- G. Unless specifically indicated or approved by Architect/Engineer, do not provide support from roof deck.
- H. Do not penetrate or otherwise notch or cut structural members without approval of Structural Engineer.
- I. Equipment Support and Attachment:
 - 1. Use metal fabricated supports or supports assembled from metal channel (strut) to support equipment as required.
 - 2. Use metal channel (strut) secured to studs to support equipment surface-mounted on hollow stud walls when wall strength is not sufficient to resist pull-out.
 - 3. Use metal channel (strut) to support surface-mounted equipment in wet or damp locations to provide space between equipment and mounting surface.
 - 4. Securely fasten floor-mounted equipment. Do not install equipment such that it relies on its own weight for support.
- J. Conduit Support and Attachment: Also comply with Section 26 0533.13.
- K. Secure fasteners according to manufacturer's recommended torque settings.
- L. Remove temporary supports.
- M. Identify independent electrical component support wires above accessible ceilings (only where specifically indicated or permitted) with color distinguishable from ceiling support wires in accordance with NFPA 70.
- N. Mounting and Anchorage of Surface-Mounted Equipment and Components: Anchor and fasten electrical items and their supports to building structural elements by the following methods unless otherwise indicated by code:
 - 1. To Wood: Fasten with lag screws or through bolts.
 - 2. To New Concrete: Bolt to concrete inserts.

3. To Masonry: Approved toggle-type bolts on hollow masonry units and expansion anchor fasteners on solid masonry units.
4. To Existing Concrete: Expansion anchor fasteners.
5. To Steel: Beam clamps (MSS Type 19, 21, 23, 25, or 27) complying with MSS SP-69.
6. To Light Steel: Sheet metal screws.
7. Items Mounted on Hollow Walls and Nonstructural Building Surfaces: Mount cabinets, panelboards, disconnect switches, control enclosures, pull and junction boxes, transformers, and other devices on slotted-channel racks attached to substrate by means that meet anchorage requirements.

3.3 FIELD QUALITY CONTROL

- A. Inspect support and attachment components for damage and defects.
- B. Repair cuts and abrasions in galvanized finishes using zinc-rich paint recommended by manufacturer. Replace components that exhibit signs of corrosion.
- C. Correct deficiencies and replace damaged or defective support and attachment components.

END OF SECTION

This page intentionally left blank

SECTION 26 0533.13
CONDUIT FOR ELECTRICAL SYSTEMS

PART 1 GENERAL

1.1 SECTION INCLUDES

- A. Flexible metal conduit (FMC).
- B. Electrical metallic tubing (EMT).
- C. Conduit fittings.
- D. Accessories.

1.2 RELATED REQUIREMENTS

- A. Section 26 0526 - Grounding and Bonding for Electrical Systems.
 - 1. Includes additional requirements for fittings for grounding and bonding.

1.3 REFERENCE STANDARDS

- A. ANSI C80.1 - American National Standard for Electrical Rigid Steel Conduit (ERSC) 2020.
- B. ANSI C80.3 - American National Standard for Electrical Metallic Tubing -- Steel (EMT-S) 2020.
- C. ANSI C80.6 - American National Standard for Electrical Intermediate Metal Conduit 2018.
- D. NECA 1 - Standard for Good Workmanship in Electrical Construction 2015.
- E. NECA 101 - Standard for Installing Steel Conduits (Rigid, IMC, EMT) 2020.
- F. NECA 111 - Standard for Installing Nonmetallic Raceways (RNC, ENT, LFNC) 2017.
- G. NEMA FB 1 - Fittings, Cast Metal Boxes, and Conduit Bodies for Conduit, Electrical Metallic Tubing, and Cable 2014.
- H. NEMA TC 2 - Electrical Polyvinyl Chloride (PVC) Conduit 2020.
- I. NEMA TC 3 - Polyvinyl Chloride (PVC) Fittings for Use with Rigid PVC Conduit and Tubing 2021.
- J. NFPA 70 - National Electrical Code Most Recent Edition Adopted by Authority Having Jurisdiction, Including All Applicable Amendments and Supplements.
- K. UL 1 - Flexible Metal Conduit Current Edition, Including All Revisions.
- L. UL 6 - Electrical Rigid Metal Conduit-Steel Current Edition, Including All Revisions.
- M. UL 360 - Liquid-Tight Flexible Metal Conduit Current Edition, Including All Revisions.
- N. UL 514B - Conduit, Tubing, and Cable Fittings Current Edition, Including All Revisions.
- O. UL 651 - Schedule 40, 80, Type EB and A Rigid PVC Conduit and Fittings Current Edition, Including All Revisions.
- P. UL 797 - Electrical Metallic Tubing-Steel Current Edition, Including All Revisions.
- Q. UL 1242 - Electrical Intermediate Metal Conduit-Steel Current Edition, Including All Revisions.

1.4 ADMINISTRATIVE REQUIREMENTS

A. Coordination:

1. Coordinate minimum sizes of conduits with the actual conductors to be installed, including adjustments for conductor sizes increased for voltage drop.
2. Coordinate the arrangement of conduits with structural members, ductwork, piping, equipment, and other potential conflicts installed under other sections or by others.
3. Verify exact conduit termination locations required for boxes, enclosures, and equipment installed under other sections or by others.
4. Coordinate the work with other trades to provide roof penetrations that preserve the integrity of the roofing system and do not void the roof warranty.
5. Notify Architect/Engineer of any conflicts with or deviations from the contract documents. Obtain direction before proceeding with work.

B. Sequencing:

1. Do not begin installation of conductors and cables until installation of conduit is complete between outlet, junction, and splicing points.

1.5 QUALITY ASSURANCE

A. Conform to requirements of NFPA 70.

B. Product Listing Organization Qualifications: An organization recognized by OSHA as a Nationally Recognized Testing Laboratory (NRTL) and acceptable to authorities having jurisdiction.

1.6 DELIVERY, STORAGE, AND HANDLING

A. Receive, inspect, handle, and store conduit and fittings in accordance with manufacturer's instructions.

PART 2 PRODUCTS

2.1 CONDUIT APPLICATIONS

A. Do not use conduit and associated fittings for applications other than as permitted by NFPA 70 and product listing.

B. Unless otherwise indicated and where not otherwise restricted, use the conduit types indicated for the specified applications. Where more than one listed application applies, comply with the most restrictive requirements. Where conduit type for a particular application is not specified, use galvanized steel rigid metal conduit.

C. Exposed, Interior, Not Subject to Physical Damage: Use electrical metallic tubing (EMT).

D. Connections to Luminaires Above Accessible Ceilings: Use flexible metal conduit.

1. Maximum Length: 6 feet (1.8 m).

E. Connections to Vibrating Equipment:

1. Dry Locations: Use flexible metal conduit.
2. Damp, Wet, or Corrosive Locations: Use liquidtight flexible metal conduit.
3. Maximum Length: 6 feet (1.8 m) unless otherwise indicated.

- 4. Vibrating equipment includes, but is not limited to:
 - a. Transformers.
 - b. Motors.
- F. Fished in Existing Walls, Where Necessary: Use flexible metal conduit.

2.2 CONDUIT REQUIREMENTS

- A. Existing Work: Where existing conduits are indicated to be reused, they may be reused only where they comply with specified requirements, are free from corrosion, and integrity is verified by pulling a mandrel through them.
- B. Fittings for Grounding and Bonding: Also comply with Section 26 0526.
- C. Provide all conduit, fittings, supports, and accessories required for a complete raceway system.
- D. Provide products listed, classified, and labeled as suitable for the purpose intended.
- E. Minimum Conduit Size, Unless Otherwise Indicated:
 - 1. Branch Circuits: 3/4 inch (21 mm) trade size.
 - 2. Branch Circuit Homeruns: 3/4 inch (21 mm) trade size.
- F. Where conduit size is not indicated, size to comply with NFPA 70 but not less than applicable minimum size requirements specified.

2.3 FLEXIBLE METAL CONDUIT (FMC)

- A. Description: NFPA 70, Type FMC standard wall steel flexible metal conduit listed and labeled as complying with UL 1 and listed for use in classified firestop systems to be used.
- B. Fittings:
 - 1. Description: Fittings complying with NEMA FB 1 and listed and labeled as complying with UL 514B.
 - 2. Material: Use steel or malleable iron.

2.4 LIQUIDTIGHT FLEXIBLE METAL CONDUIT (LFMC)

- A. Description: NFPA 70, Type LFMC polyvinyl chloride (PVC) jacketed steel flexible metal conduit listed and labeled as complying with UL 360.
- B. Fittings:
 - 1. Description: Fittings complying with NEMA FB 1 and listed and labeled as complying with UL 514B.
 - 2. Material: Use steel or malleable iron.

2.5 ELECTRICAL METALLIC TUBING (EMT)

- A. Description: NFPA 70, Type EMT steel electrical metallic tubing complying with ANSI C80.3 and listed and labeled as complying with UL 797.
- B. Fittings:
 - 1. Description: Fittings complying with NEMA FB 1 and listed and labeled as complying with UL 514B.
 - 2. Material: Use steel.

3. Connectors and Couplings: Use compression (gland) type.
 - a. Do not use indenter type connectors and couplings.
 - b. Do not use set-screw type connectors and couplings.
4. Damp or Wet Locations (where permitted): Use fittings listed for use in wet locations.
5. Embedded Within Concrete (where permitted): Use fittings listed as concrete-tight. Fittings that require taping to be concrete-tight are not acceptable.

2.6 ACCESSORIES

- A. Conduit Joint Compound: Corrosion-resistant, electrically conductive; suitable for use with the conduit to be installed.
- B. Pull Strings: Use nylon cord with average breaking strength of not less than 200 pound-force (890 N).
- C. Sealing Compound for Sealing Fittings: Listed for use with the particular fittings to be installed.
- D. Modular Seals for Conduit Penetrations: Rated for minimum of 40 psig; Suitable for the conduits to be installed.

PART 3 EXECUTION

3.1 EXAMINATION

- A. Verify that field measurements are as indicated.
- B. Verify that mounting surfaces are ready to receive conduits.
- C. Verify that conditions are satisfactory for installation prior to starting work.

3.2 INSTALLATION

- A. Install products in accordance with manufacturer's instructions.
- B. Perform work in accordance with NECA 1 (general workmanship).
- C. Install galvanized steel rigid metal conduit (RMC) in accordance with NECA 101.
- D. Install intermediate metal conduit (IMC) in accordance with NECA 101.
- E. Install rigid polyvinyl chloride (PVC) conduit in accordance with NECA 111.
- F. Conduit Routing:
 1. Unless dimensioned, conduit routing indicated is diagrammatic.
 2. When conduit destination is indicated without specific routing, determine exact routing required.
 3. Conceal all conduits unless specifically indicated to be exposed.
 4. Conduits in the following areas may be exposed, unless otherwise indicated:
 - a. Electrical rooms.
 - b. Mechanical equipment rooms.
 - c. Within joists in areas with no ceiling.

5. Unless otherwise approved, do not route conduits exposed:
 - a. Across floors.
 - b. Across roofs.
 - c. Across top of parapet walls.
 - d. Across building exterior surfaces.
 6. Conduits installed underground or embedded in concrete may be routed in the shortest possible manner unless otherwise indicated. Route all other conduits parallel or perpendicular to building structure and surfaces, following surface contours where practical.
 7. Arrange conduit to maintain adequate headroom, clearances, and access.
 8. Arrange conduit to provide no more than the equivalent of four 90 degree bends between pull points.
 9. Arrange conduit to provide no more than 150 feet (46 m) between pull points.
 10. Route conduits above water and drain piping where possible.
 11. Arrange conduit to prevent moisture traps. Provide drain fittings at low points and at sealing fittings where moisture may collect.
 12. Maintain minimum clearance of 6 inches (150 mm) between conduits and piping for other systems.
 13. Maintain minimum clearance of 12 inches (300 mm) between conduits and hot surfaces. This includes, but is not limited to:
 - a. Heaters.
 - b. Hot water piping.
 - c. Flues.
 14. Group parallel conduits in the same area together on a common rack.
- G. Conduit Support:
1. Secure and support conduits in accordance with NFPA 70 and Section 26 0529 using suitable supports and methods approved by the authority having jurisdiction.
 2. Provide independent support from building structure. Do not provide support from piping, ductwork, or other systems.
 3. Installation Above Suspended Ceilings: Do not provide support from ceiling support system. Do not provide support from ceiling grid or allow conduits to lay on ceiling tiles.
 4. Use metal channel (strut) with accessory conduit clamps to support multiple parallel surface-mounted conduits.
 5. Use conduit clamp to support single conduit from beam clamp or threaded rod.
 6. Use trapeze hangers assembled from threaded rods and metal channel (strut) with accessory conduit clamps to support multiple parallel suspended conduits.
 7. Use of wire for support of conduits is not permitted.
 8. Where conduit support intervals specified in NFPA 70 and NECA standards differ, comply with the most stringent requirements.

H. Connections and Terminations:

1. Use approved zinc-rich paint or conduit joint compound on field-cut threads of galvanized steel conduits prior to making connections.
2. Where two threaded conduits must be joined and neither can be rotated, use three-piece couplings or split couplings. Do not use running threads.
3. Use suitable adapters where required to transition from one type of conduit to another.
4. Provide drip loops for liquidtight flexible conduit connections to prevent drainage of liquid into connectors.
5. Terminate threaded conduits in boxes and enclosures using threaded hubs or double lock nuts for dry locations and raintight hubs for wet locations.
6. Where spare conduits stub up through concrete floors and are not terminated in a box or enclosure, provide threaded couplings equipped with threaded plugs set flush with finished floor.
7. Provide insulating bushings or insulated throats at all conduit terminations to protect conductors.
8. Secure joints and connections to provide maximum mechanical strength and electrical continuity.

I. Penetrations:

1. Do not penetrate or otherwise notch or cut structural members, including footings and grade beams, without approval of Structural Engineer.
2. Make penetrations perpendicular to surfaces unless otherwise indicated.
3. Provide sleeves for penetrations as indicated or as required to facilitate installation. Set sleeves flush with exposed surfaces unless otherwise indicated or required.
4. Conceal bends for conduit risers emerging above ground.
5. Seal interior of conduits entering the building from underground at first accessible point to prevent entry of moisture and gases.
6. Provide suitable modular seal where conduits penetrate exterior wall below grade.
7. Where conduits penetrate waterproof membrane, seal as required to maintain integrity of membrane.
8. Fire Safing
 - a. Metal piping and sleeves passing through floors, roof, partitions, and fire walls, shall be provided with firestop by packing space between pipe and sleeve with UL listed non-sag and self-leveling fire safing insulation per manufacturer's instructions.
 - b. Plastic piping passing through fire rated floors and fire rated walls shall be provided with firestop by providing intumescent wrap strip around the pipe, enclosed in steel collar attached to structure.
 - c. Cracks, Voids, or Holes Up to 4" Diameter: Use non-sag or self-leveling putty or caulking, one-piece intumescent elastomer, non-corrosive to metal, compatible with synthetic cable jackets, and capable of expanding 10 times when exposed to flame or heat, UL listed.
 - d. Seal all holes or voids made by penetrations to ensure an effective barrier against smoke, fire, toxic and combustible gases.

- e. Unless protected, from possible loading or traffic, install firestopping materials in floors having void openings or four (4) inches or more to support the same floor load requirements.
- f. Manufacturer: Subject to compliance with requirements, provide non-sag and self-leveling fire barrier caulk, wrap/strip, moldable putty, and sheet forms of one of the following:
 - 1) 3M Brand.
 - 2) Flame Stop.
 - 3) Dow Corning.
 - 4) Metacaulk.
 - 5) Engineer Pre-Approved Equivalent.
- J. Conduit Movement Provisions: Where conduits are subject to movement, provide expansion and expansion/deflection fittings to prevent damage to enclosed conductors or connected equipment. This includes, but is not limited to:
 - 1. Where conduits cross structural joints intended for expansion, contraction, or deflection.
 - 2. Where conduits are subject to earth movement by settlement or frost.
- K. Condensation Prevention: Where conduits cross barriers between areas of potential substantial temperature differential, provide sealing fitting or approved sealing compound at an accessible point near the penetration to prevent condensation. This includes, but is not limited to:
 - 1. Where conduits pass from outdoors into conditioned interior spaces.
 - 2. Where conduits pass from unconditioned interior spaces into conditioned interior spaces.
- L. Provide pull string in all empty conduits and in conduits where conductors and cables are to be installed by others. Leave minimum slack of 12 inches (300 mm) at each end.
- M. Provide grounding and bonding in accordance with Section 26 0526.
- N. Identify conduits in accordance with Section 26 0553.

3.3 FIELD QUALITY CONTROL

- A. Repair cuts and abrasions in galvanized finishes using zinc-rich paint recommended by manufacturer. Replace components that exhibit signs of corrosion.
- B. Correct deficiencies and replace damaged or defective conduits.

3.4 CLEANING

- A. Clean interior of conduits to remove moisture and foreign matter.

3.5 PROTECTION

- A. Immediately after installation of conduit, use suitable manufactured plugs to provide protection from entry of moisture and foreign material and do not remove until ready for installation of conductors.

END OF SECTION

This page intentionally left blank

SECTION 26 0533.16
BOXES FOR ELECTRICAL SYSTEMS

PART 1 GENERAL

1.1 SECTION INCLUDES

- A. Outlet and device boxes up to 100 cubic inches (1,650 cu cm), including those used as junction and pull boxes.
- B. Cabinets and enclosures, including junction and pull boxes larger than 100 cubic inches (1,650 cu cm).

1.2 RELATED REQUIREMENTS

- A. Section 26 0529 - Hangers and Supports for Electrical Systems.
- B. Section 26 0553 - Identification for Electrical Systems: Identification products and requirements.

1.3 REFERENCE STANDARDS

- A. NECA 1 - Standard for Good Workmanship in Electrical Construction 2015.
- B. NECA 130 - Standard for Installing and Maintaining Wiring Devices 2016.
- C. NEMA FB 1 - Fittings, Cast Metal Boxes, and Conduit Bodies for Conduit, Electrical Metallic Tubing, and Cable 2014.
- D. NEMA OS 1 - Sheet-Steel Outlet Boxes, Device Boxes, Covers, and Box Supports 2013 (Reaffirmed 2020).
- E. NEMA 250 - Enclosures for Electrical Equipment (1000 Volts Maximum) 2020.
- F. NFPA 70 - National Electrical Code Most Recent Edition Adopted by Authority Having Jurisdiction, Including All Applicable Amendments and Supplements.
- G. UL 50 - Enclosures for Electrical Equipment, Non-Environmental Considerations Current Edition, Including All Revisions.
- H. UL 50E - Enclosures for Electrical Equipment, Environmental Considerations Current Edition, Including All Revisions.
- I. UL 508A - Industrial Control Panels Current Edition, Including All Revisions.
- J. UL 514A - Metallic Outlet Boxes Current Edition, Including All Revisions.

1.4 ADMINISTRATIVE REQUIREMENTS

- A. Coordination:
 - 1. Coordinate the work with other trades to avoid placement of ductwork, piping, equipment, or other potential obstructions within the dedicated equipment spaces and working clearances for electrical equipment required by NFPA 70.
 - 2. Coordinate arrangement of electrical equipment with the dimensions and clearance requirements of the actual equipment to be installed.
 - 3. Coordinate minimum sizes of boxes with the actual installed arrangement of conductors, clamps, support fittings, and devices, calculated according to NFPA 70.

IA DAS - FDCF Bldg A Water Heater Replacement
Project # 2142301160

4. Coordinate minimum sizes of pull boxes with the actual installed arrangement of connected conduits, calculated according to NFPA 70.
5. Coordinate the placement of boxes with millwork, furniture, devices, equipment, etc. installed under other sections or by others.
6. Coordinate the work with other trades to preserve insulation integrity.
7. Coordinate the work with other trades to provide walls suitable for installation of flush-mounted boxes where indicated.
8. Notify Architect/Engineer of any conflicts with or deviations from the contract documents. Obtain direction before proceeding with work.

1.5 QUALITY ASSURANCE

- A. Conform to requirements of NFPA 70.
- B. Maintain at the project site a copy of each referenced document that prescribes execution requirements.
- C. Product Listing Organization Qualifications: An organization recognized by OSHA as a Nationally Recognized Testing Laboratory (NRTL) and acceptable to authorities having jurisdiction.

1.6 DELIVERY, STORAGE, AND HANDLING

- A. Receive, inspect, handle, and store products in accordance with manufacturer's instructions.

PART 2 PRODUCTS

2.1 BOXES

- A. General Requirements:
 1. Do not use boxes and associated accessories for applications other than as permitted by NFPA 70 and product listing.
 2. Provide all boxes, fittings, supports, and accessories required for a complete raceway system and to accommodate devices and equipment to be installed.
 3. Provide products listed, classified, and labeled as suitable for the purpose intended.
 4. Where box size is not indicated, size to comply with NFPA 70 but not less than applicable minimum size requirements specified.
 5. Provide grounding terminals within boxes where equipment grounding conductors terminate.
- B. Outlet and Device Boxes Up to 100 cubic inches (1,650 cu cm), Including Those Used as Junction and Pull Boxes:
 1. Use sheet-steel boxes for dry locations unless otherwise indicated or required.
 2. Use cast iron boxes or cast aluminum boxes for damp or wet locations unless otherwise indicated or required; furnish with compatible weatherproof gasketed covers.
 3. Use suitable concrete type boxes where flush-mounted in concrete.
 4. Use suitable masonry type boxes where flush-mounted in masonry walls.
 5. Use raised covers suitable for the type of wall construction and device configuration where required.

6. Use shallow boxes where required by the type of wall construction.
 7. Do not use "through-wall" boxes designed for access from both sides of wall.
 8. Sheet-Steel Boxes: Comply with NEMA OS 1, and list and label as complying with UL 514A.
 9. Cast Metal Boxes: Comply with NEMA FB 1, and list and label as complying with UL 514A; furnish with threaded hubs.
 10. Boxes for Supporting Luminaires and Ceiling Fans: Listed as suitable for the type and weight of load to be supported; furnished with fixture stud to accommodate mounting of luminaire where required.
 11. Boxes for Ganged Devices: Use multigang boxes of single-piece construction. Do not use field-connected gangable boxes unless specifically indicated or permitted.
 12. Wall Plates: Comply with Section 26 2726.
- C. Cabinets and Enclosures, Including Junction and Pull Boxes Larger Than 100 cubic inches (1,650 cu cm):
1. Comply with NEMA 250, and list and label as complying with UL 50 and UL 50E, or UL 508A.
 2. NEMA 250 Environment Type, Unless Otherwise Indicated:
 - a. Indoor Clean, Dry Locations: Type 1, galvanized steel.
 3. Junction and Pull Boxes Larger Than 100 cubic inches (1,650 cu cm):
 - a. Provide screw-cover or hinged-cover enclosures unless otherwise indicated.

PART 3 EXECUTION

3.1 EXAMINATION

- A. Verify that mounting surfaces are ready to receive boxes.
- B. Verify that conditions are satisfactory for installation prior to starting work.

3.2 INSTALLATION

- A. Install products in accordance with manufacturer's instructions.
- B. Install boxes in accordance with NECA 1 (general workmanship) and, where applicable, NECA 130, including mounting heights specified in those standards where mounting heights are not indicated.
- C. Arrange equipment to provide minimum clearances in accordance with manufacturer's instructions and NFPA 70.
- D. Unless otherwise indicated, provide separate boxes for line voltage and low voltage systems.
- E. Flush-mount boxes in finished areas unless specifically indicated to be surface-mounted.
- F. Unless otherwise indicated, boxes may be surface-mounted where exposed conduits are indicated or permitted.
- G. Box Locations:
 1. Unless dimensioned, box locations indicated are approximate.

IA DAS - FDCF Bldg A Water Heater Replacement
Project # 2142301160

2. Locate boxes as required for devices installed under other sections or by others.
 - a. Switches, Receptacles, and Other Wiring Devices: Comply with Section 26 2726.
 3. Locate boxes so that wall plates do not span different building finishes.
 4. Locate boxes so that wall plates do not cross masonry joints.
 5. Unless otherwise indicated, where multiple outlet boxes are installed at the same location at different mounting heights, install along a common vertical center line.
 6. Do not install flush-mounted boxes on opposite sides of walls back-to-back. Provide minimum 6 inches (150 mm) horizontal separation unless otherwise indicated.
 7. Acoustic-Rated Walls: Do not install flush-mounted boxes on opposite sides of walls back-to-back; provide minimum 24 inches (610 mm) horizontal separation.
 8. Fire Resistance Rated Walls: Install flush-mounted boxes such that the required fire resistance will not be reduced.
 - a. Do not install flush-mounted boxes on opposite sides of walls back-to-back; provide minimum 24 inches (610 mm) separation where wall is constructed with individual noncommunicating stud cavities or protect both boxes with listed putty pads.
 - b. Do not install flush-mounted boxes with area larger than 16 square inches (0.0103 sq m) or such that the total aggregate area of openings exceeds 100 square inches (0.0645 sq m) for any 100 square feet (9.29 sq m) of wall area.
 9. Locate junction and pull boxes in the following areas, unless otherwise indicated or approved by the Architect:
 - a. Concealed above accessible suspended ceilings.
 - b. Within joists in areas with no ceiling.
 - c. Electrical rooms.
 - d. Mechanical equipment rooms.
- H. Box Supports:
1. Secure and support boxes in accordance with NFPA 70 and Section 26 0529 using suitable supports and methods approved by the authority having jurisdiction.
 2. Provide independent support from building structure except for cast metal boxes (other than boxes used for fixture support) supported by threaded conduit connections in accordance with NFPA 70. Do not provide support from piping, ductwork, or other systems.
 3. Installation Above Suspended Ceilings: Do not provide support from ceiling grid or ceiling support system.
- I. Install boxes plumb and level.
- J. Flush-Mounted Boxes:
1. Install boxes in noncombustible materials such as concrete, tile, gypsum, plaster, etc. so that front edge of box or associated raised cover is not set back from finished surface more than 1/4 inch (6 mm) or does not project beyond finished surface.
 2. Install boxes in combustible materials such as wood so that front edge of box or associated raised cover is flush with finished surface.

- 3. Repair rough openings around boxes in noncombustible materials such as concrete, tile, gypsum, plaster, etc. so that there are no gaps or open spaces greater than 1/8 inch (3 mm) at the edge of the box.
- K. Install boxes as required to preserve insulation integrity.
- L. Install permanent barrier between ganged wiring devices when voltage between adjacent devices exceeds 300 V.
- M. Close unused box openings.
- N. Install blank wall plates on junction boxes and on outlet boxes with no devices or equipment installed or designated for future use.
- O. Provide grounding and bonding in accordance with Section 26 0526.
- P. Identify boxes in accordance with Section 26 0553.

3.3 CLEANING

- A. Clean interior of boxes to remove dirt, debris, plaster, and other foreign material.

3.4 PROTECTION

- A. Immediately after installation, protect boxes from entry of moisture and foreign material until ready for installation of conductors.

END OF SECTION

This page intentionally left blank

**SECTION 26 0553
IDENTIFICATION FOR ELECTRICAL SYSTEMS**

PART 1 GENERAL

1.1 SECTION INCLUDES

- A. Electrical identification requirements.
- B. Identification nameplates and labels.
- C. Wire and cable markers.
- D. Voltage markers.
- E. Underground warning tape.
- F. Warning signs and labels.

1.2 RELATED REQUIREMENTS

- A. Section 26 0519 - Low-Voltage Electrical Power Conductors and Cables: Color coding for power conductors and cables 600 V and less; vinyl color coding electrical tape.
- B. Section 26 2726 Wiring Devices: Device and wallplate finishes; factory pre-marked wallplates.

1.3 REFERENCE STANDARDS

- A. ANSI Z535.2 - American National Standard for Environmental and Facility Safety Signs 2011.
- B. ANSI Z535.4 - American National Standard for Product Safety Signs and Labels 2011.
- C. NFPA 70 - National Electrical Code Most Recent Edition Adopted by Authority Having Jurisdiction, Including All Applicable Amendments and Supplements.
- D. NFPA 70E - Standard for Electrical Safety in the Workplace 2021.
- E. UL 969 - Marking and Labeling Systems Current Edition, Including All Revisions.

1.4 ADMINISTRATIVE REQUIREMENTS

- A. Coordination:
 - 1. Verify final designations for equipment, systems, and components to be identified prior to fabrication of identification products.
- B. Sequencing:
 - 1. Do not conceal items to be identified, in locations such as above suspended ceilings, until identification products have been installed.
 - 2. Do not install identification products until final surface finishes and painting are complete.

1.5 QUALITY ASSURANCE

- A. Conform to requirements of NFPA 70.

1.6 FIELD CONDITIONS

- A. Do not install adhesive products when ambient temperature is lower than recommended by manufacturer.

PART 2 PRODUCTS

2.1 IDENTIFICATION REQUIREMENTS

A. Identification for Equipment:

1. Use identification nameplate to identify each piece of electrical distribution and control equipment and associated sections, compartments, and components.
 - a. Panelboards:
 - 1) Identify power source and circuit number. Include location.
 - 2) Use typewritten circuit directory to identify load(s) served for panelboards with a door. Identify spares and spaces using pencil.
 - 3) For power panelboards without a door, use identification nameplate to identify load(s) served for each branch device. Do not identify spares and spaces.
 - b. Enclosed switches, circuit breakers, and motor controllers:
 - 1) Identify voltage and phase.
 - 2) Identify power source and circuit number. Include location.
 - 3) Identify load(s) served. Include location.
2. Use identification nameplate to identify equipment utilizing series ratings, where permitted, in accordance with NFPA 70.
3. Use identification nameplate to identify disconnect location for equipment with remote disconnecting means.
4. Use identification label on inside of door at each fused switch to identify required NEMA fuse class and size.
5. Available Fault Current Documentation: Use identification label to identify the available fault current and date calculations were performed at locations requiring documentation by NFPA 70 including but not limited to the following.
 - a. Service equipment.
 - b. Motor control centers.
6. Use warning signs to identify electrical hazards for entrances to all rooms and other guarded locations that contain exposed live parts operating at 600 V nominal or less with the word message "DANGER; Electrical hazard; Authorized personnel only" or approved equivalent.

B. Identification for Conductors and Cables:

1. Color Coding for Power Conductors 600 V and Less: Comply with Section 26 0519.
2. Use identification nameplate or identification label to identify color code for ungrounded and grounded power conductors inside door or enclosure at each piece of feeder or branch-circuit distribution equipment when premises has feeders or branch circuits served by more than one nominal voltage system.
3. Use wire and cable markers to identify circuit number or other designation indicated for power, control, and instrumentation conductors and cables at the following locations:
 - a. At each source and load connection.
 - b. Within boxes when more than one circuit is present.

- c. Within equipment enclosures when conductors and cables enter or leave the enclosure.
- 4. Use wire and cable markers to identify connected grounding electrode system components for grounding electrode conductors.
- 5. Use underground warning tape to identify direct buried cables.
- C. Identification for Boxes:
 - 1. Use voltage markers to identify highest voltage present.
 - 2. Use identification labels to identify circuits enclosed.
 - 3. Use warning labels to identify electrical hazards for boxes containing exposed live parts or exposed conductors operating at over 600 V nominal with the word message "DANGER; HIGH VOLTAGE; KEEP OUT".
- D. Identification for Devices:
 - 1. Wiring Device and Wallplate Finishes: Comply with Section 26 2726.
 - 2. Use identification label to identify fire alarm system devices.
 - a. For devices concealed above suspended ceilings, provide additional identification on ceiling tile below device location.
 - 3. Use identification label or engraved wallplate to identify serving branch circuit for all receptacles.
 - a. For receptacles in public areas or in areas as directed by Architect, provide identification on inside surface of wallplate.
 - 4. Use identification label or engraved wallplate to identify load controlled for wall-mounted control devices controlling loads that are not visible from the control location and for multiple wall-mounted control devices installed at one location.
 - 5. Use identification label to identify receptacles protected by upstream GFI protection, where permitted.

2.2 IDENTIFICATION NAMEPLATES AND LABELS

- A. Identification Nameplates:
 - 1. Materials:
 - a. Indoor Clean, Dry Locations: Use plastic nameplates.
 - b. Outdoor Locations: Use plastic, stainless steel, or aluminum nameplates suitable for exterior use.
 - 2. Plastic Nameplates: Two-layer or three-layer laminated acrylic or electrically non-conductive phenolic with beveled edges; minimum thickness of 1/16 inch (1.6 mm); engraved text.
 - a. Exception: Provide minimum thickness of 1/8 inch (3 mm) when any dimension is greater than 4 inches (100 mm).
 - 3. Stainless Steel Nameplates: Minimum thickness of 1/32 inch (0.8 mm); engraved or laser-etched text.

IA DAS - FDCF Bldg A Water Heater Replacement
Project # 2142301160

4. Aluminum Nameplates: Anodized; minimum thickness of 1/32 inch (0.8 mm); engraved or laser-etched text.
 5. Mounting Holes for Mechanical Fasteners: Two, centered on sides for sizes up to 1 inch (25 mm) high; Four, located at corners for larger sizes.
- B. Identification Labels:
1. Materials: Use self-adhesive laminated plastic labels; UV, chemical, water, heat, and abrasion resistant.
 2. Text: Use factory pre-printed or machine-printed text. Do not use handwritten text unless otherwise indicated.
- C. Format for Equipment Identification:
1. Minimum Size: 1 inch (25 mm) by 2.5 inches (64 mm).
 2. Legend:
 - a. Equipment designation or other approved description.
 3. Text: All capitalized unless otherwise indicated.
 4. Minimum Text Height:
 - a. Equipment Designation: 1/2 inch (13 mm).
 5. Color:
 - a. Normal Power System: White text on black background.
- D. Format for General Information and Operating Instructions:
1. Minimum Size: 1 inch (25 mm) by 2.5 inches (64 mm).
 2. Legend: Include information or instructions indicated or as required for proper and safe operation and maintenance.
 3. Text: All capitalized unless otherwise indicated.
 4. Minimum Text Height: 1/4 inch (6 mm).
 5. Color: Black text on white background unless otherwise indicated.
- E. Format for Receptacle Identification:
1. Minimum Size: 3/8 inch (10 mm) by 1.5 inches (38 mm).
 2. Legend: Power source and circuit number or other designation indicated.
 - a. Include voltage and phase for other than 120 V, single phase circuits.
 3. Text: All capitalized unless otherwise indicated.
 4. Minimum Text Height: 3/16 inch (5 mm).
 5. Color: Black text on clear background.

2.3 WIRE AND CABLE MARKERS

- A. Markers for Conductors and Cables: Use wrap-around self-adhesive vinyl cloth, wrap-around self-adhesive vinyl self-laminating, heat-shrink sleeve, plastic sleeve, plastic clip-on, or vinyl split sleeve type markers suitable for the conductor or cable to be identified.
- B. Markers for Conductor and Cable Bundles: Use plastic marker tags secured by nylon cable ties.

- C. Legend: Power source and circuit number or other designation indicated.
- D. Text: Use factory pre-printed or machine-printed text, all capitalized unless otherwise indicated.
 - 1. Do not use handwritten text.
- E. Minimum Text Height: 1/8 inch (3 mm).
- F. Color: Black text on white background unless otherwise indicated.

2.4 VOLTAGE MARKERS

- A. Markers for Conduits: Use factory pre-printed self-adhesive vinyl, self-adhesive vinyl cloth, or vinyl snap-around type markers.
- B. Markers for Boxes and Equipment Enclosures: Use factory pre-printed self-adhesive vinyl or self-adhesive vinyl cloth type markers.
- C. Minimum Size:
 - 1. Markers for Conduits: As recommended by manufacturer for conduit size to be identified.
 - 2. Markers for Pull Boxes: 1 1/8 by 4 1/2 inches (29 by 110 mm).
 - 3. Markers for Junction Boxes: 1/2 by 2 1/4 inches (13 by 57 mm).
- D. Legend:
 - 1. Markers for Voltage Identification: Highest voltage present.
 - 2. Markers for System Identification:
- E. Color: Black text on orange background unless otherwise indicated.

2.5 WARNING SIGNS AND LABELS

- A. Comply with ANSI Z535.2 or ANSI Z535.4 as applicable.
- B. Warning Signs:
 - 1. Materials:
 - a. Indoor Dry, Clean Locations: Use factory pre-printed rigid plastic or self-adhesive vinyl signs.
 - b. Outdoor Locations: Use factory pre-printed rigid aluminum signs.
 - 2. Rigid Signs: Provide four mounting holes at corners for mechanical fasteners.
 - 3. Minimum Size: 7 by 10 inches (178 by 254 mm) unless otherwise indicated.
- C. Warning Labels:
 - 1. Materials: Use factory pre-printed or machine-printed self-adhesive polyester or self-adhesive vinyl labels; UV, chemical, water, heat, and abrasion resistant; produced using materials recognized to UL 969.
 - a. Do not use labels designed to be completed using handwritten text.
 - b. Provide polyester overlamine to protect handwritten text.
 - 2. Machine-Printed Labels: Use thermal transfer process printing machines and accessories recommended by label manufacturer.
 - 3. Minimum Size: 2 by 4 inches (51 mm by 102 mm) unless otherwise indicated.

PART 3 EXECUTION

3.1 PREPARATION

- A. Clean surfaces to receive adhesive products according to manufacturer's instructions.

3.2 INSTALLATION

- A. Install products in accordance with manufacturer's instructions.
- B. Install identification products to be plainly visible for examination, adjustment, servicing, and maintenance. Unless otherwise indicated, locate products as follows:
 - 1. Surface-Mounted Equipment: Enclosure front.
 - 2. Flush-Mounted Equipment: Inside of equipment door.
 - 3. Free-Standing Equipment: Enclosure front; also enclosure rear for equipment with rear access.
 - 4. Elevated Equipment: Legible from the floor or working platform.
 - 5. Branch Devices: Adjacent to device.
 - 6. Interior Components: Legible from the point of access.
 - 7. Conduits: Legible from the floor.
 - 8. Boxes: Outside face of cover.
 - 9. Conductors and Cables: Legible from the point of access.
 - 10. Devices: Outside face of cover.
- C. Install identification products centered, level, and parallel with lines of item being identified.
- D. Secure nameplates to exterior surfaces of enclosures using stainless steel screws and to interior surfaces using self-adhesive backing or epoxy cement.
- E. Install self-adhesive labels and markers to achieve maximum adhesion, with no bubbles or wrinkles and edges properly sealed.
- F. Install underground warning tape above buried lines with one tape per trench at 3 inches (75 mm) below finished grade.
- G. Secure rigid signs using stainless steel screws.
- H. Mark all handwritten text, where permitted, to be neat and legible.

3.3 FIELD QUALITY CONTROL

- A. Replace self-adhesive labels and markers that exhibit bubbles, wrinkles, curling or other signs of improper adhesion.

END OF SECTION

**SECTION 26 2726
WIRING DEVICES**

PART 1 GENERAL

1.1 SECTION INCLUDES

- A. Wall switches.
- B. Receptacles.
- C. Wall plates.

1.2 RELATED REQUIREMENTS

- A. Section 26 0533.16 - Boxes for Electrical Systems.
- B. Section 26 0553 - Identification for Electrical Systems: Identification products and requirements.

1.3 REFERENCE STANDARDS

- A. FS W-C-596 - Connector, Electrical, Power, General Specification for 2014h, with Amendments (2017).
- B. FS W-S-896 - Switches, Toggle (Toggle and Lock), Flush Mounted (General Specification) 2014g, with Amendment (2017).
- C. NECA 1 - Standard for Good Workmanship in Electrical Construction 2015.
- D. NECA 130 - Standard for Installing and Maintaining Wiring Devices 2016.
- E. NEMA WD 1 - General Color Requirements for Wiring Devices 1999 (Reaffirmed 2020).
- F. NEMA WD 6 - Wiring Devices - Dimensional Specifications 2021.
- G. NFPA 70 - National Electrical Code Most Recent Edition Adopted by Authority Having Jurisdiction, Including All Applicable Amendments and Supplements.
- H. UL 20 - General-Use Snap Switches Current Edition, Including All Revisions.
- I. UL 498 - Attachment Plugs and Receptacles Current Edition, Including All Revisions.
- J. UL 514D - Cover Plates for Flush-Mounted Wiring Devices Current Edition, Including All Revisions.
- K. UL 943 - Ground-Fault Circuit-Interrupters Current Edition, Including All Revisions.
- L. UL 1472 - Solid-State Dimming Controls Current Edition, Including All Revisions.
- M. UL 1917 - Solid-State Fan Speed Controls Current Edition, Including All Revisions.

1.4 ADMINISTRATIVE REQUIREMENTS

- A. Coordination:
 - 1. Coordinate the placement of outlet boxes with equipment, etc. installed under other sections or by others.
 - 2. Coordinate wiring device ratings and configurations with the electrical requirements of actual equipment to be installed.

IA DAS - FDCF Bldg A Water Heater Replacement
Project # 2142301160

3. Coordinate the placement of outlet boxes for wall switches with actual installed door swings.
 4. Coordinate the installation and preparation of uneven surfaces, such as split face block, to provide suitable surface for installation of wiring devices.
 5. Notify Architect/Engineer of any conflicts or deviations from Contract Documents to obtain direction prior to proceeding with work.
- B. Sequencing:
1. Do not install wiring devices until final surface finishes and painting are complete.

1.5 QUALITY ASSURANCE

- A. Comply with requirements of NFPA 70.
- B. Maintain at the project site a copy of each referenced document that prescribes execution requirements.
- C. Manufacturer Qualifications: Company specializing in manufacturing the products specified in this section with minimum three years documented experience.
- D. Products: Listed, classified, and labeled as suitable for the purpose intended.
- E. Product Listing Organization Qualifications: An organization recognized by OSHA as a Nationally Recognized Testing Laboratory (NRTL) and acceptable to authorities having jurisdiction.

1.6 DELIVERY, STORAGE, AND PROTECTION

- A. Store in a clean, dry space in original manufacturer's packaging until ready for installation.

PART 2 PRODUCTS

2.1 WIRING DEVICE APPLICATIONS

- A. Provide wiring devices suitable for intended use and with ratings adequate for load served.
- B. Provide weather resistant GFCI receptacles with specified weatherproof covers for receptacles installed outdoors or in damp or wet locations.
- C. Provide GFCI protection for receptacles installed within 6 feet (1.8 m) of sinks.

2.2 WIRING DEVICE FINISHES

- A. Provide wiring device finishes as described below unless otherwise indicated.
- B. Wiring Devices, Unless Otherwise Indicated: Gray with stainless steel wall plate.

2.3 WALL SWITCHES

- A. Manufacturers:
 1. Hubbell Incorporated: www.hubbell.com/#sle.
 2. Cooper Wiring Devices.
 3. Leviton Manufacturing Company, Inc: www.leviton.com/#sle.
 4. Lutron.

5. Pass & Seymour, a brand of Legrand North America, Inc: www.legrand.us/#sle.
 6. Engineer Pre-Approved Equivalent.
- B. Wall Switches - General Requirements: AC only, quiet operating, general-use snap switches with silver alloy contacts, complying with NEMA WD 1 and NEMA WD 6, and listed as complying with UL 20 and where applicable FS W-S-896; types as indicated on the drawings.
1. Wiring Provisions: Terminal screws for side wiring and screw actuated binding clamp for back wiring with separate ground terminal screw.
- C. Standard Wall Switches: Industrial specification grade, 20 A, 120/277 V with standard toggle type switch actuator and maintained contacts; single pole single throw, double pole single throw, three way, or four way as indicated on the drawings.

2.4 RECEPTACLES

- A. Manufacturers:
1. Hubbell Incorporated: www.hubbell.com/#sle.
 2. Cooper Wiring Devices.
 3. Leviton Manufacturing Company, Inc: www.leviton.com/#sle.
 4. Lutron Electronics Company, Inc: www.lutron.com/sle.
 5. Pass & Seymour, a brand of Legrand North America, Inc: www.legrand.us/#sle.
 6. Engineer Pre-Approved Equivalent.
- B. Receptacles - General Requirements: Self-grounding, complying with NEMA WD 1 and NEMA WD 6, and listed as complying with UL 498, and where applicable, FS W-C-596; types as indicated on the drawings.
1. Wiring Provisions: Terminal screws for side wiring or screw actuated binding clamp for back wiring with separate ground terminal screw.
 2. NEMA configurations specified are according to NEMA WD 6.
- C. Convenience Receptacles:
1. Standard Convenience Receptacles: Industrial specification grade, 20A, 125V, NEMA 5-20R; single or duplex as indicated on the drawings.
 2. Tamper Resistant and Weather Resistant Convenience Receptacles: Industrial specification grade, 20A, 125V, NEMA 5-20R, listed and labeled as tamper resistant type and as weather resistant type complying with UL 498 Supplement SE suitable for installation in damp or wet locations; single or duplex as indicated on the drawings.
- D. GFCI Receptacles:
1. GFCI Receptacles - General Requirements: Self-testing, with feed-through protection and light to indicate ground fault tripped condition and loss of protection; listed as complying with UL 943, class A.
 - a. Provide test and reset buttons of same color as device.
 2. Standard GFCI Receptacles: Industrial specification grade, duplex, 20A, 125V, NEMA 5-20R, rectangular decorator style.
 3. Tamper Resistant and Weather Resistant GFCI Receptacles: Industrial specification grade, duplex, 20A, 125V, NEMA 5-20R, rectangular decorator style, listed and labeled as tamper resistant type and as weather resistant type complying with UL 498 Supplement SE suitable for installation in damp or wet locations.

**IA DAS - FDCF Bldg A Water Heater Replacement
Project # 2142301160**

2.5 WALL PLATES

- A. Manufacturers:
 - 1. Hubbell Incorporated: www.hubbell-wiring.com/#sle.
 - 2. Leviton Manufacturing Company, Inc: www.leviton.com/#sle.
 - 3. Lutron Electronics Company, Inc: www.lutron.com/sle.
 - 4. Pass & Seymour, a brand of Legrand North America, Inc: www.legrand.us/#sle.
 - 5. Engineer Pre-Approved Equivalent.
- B. Wall Plates: Comply with UL 514D.
 - 1. Configuration: One piece cover as required for quantity and types of corresponding wiring devices.
 - 2. Size: Standard.
 - 3. Screws: Metal with slotted heads finished to match wall plate finish.
- C. Stainless Steel Wall Plates: Brushed satin finish, Type 302 stainless steel.
- D. Galvanized Steel Wall Plates: Rounded corners and edges, with corrosion resistant screws.
- E. Premarked Wall Plates: Factory labeled as indicated; hot stamped for nylon wall plates and engraved for metal wall plates.
- F. Weatherproof Covers for Wet or Damp Locations: Gasketed, cast aluminum, with hinged lockable cover and corrosion-resistant screws; listed as suitable for use in wet locations while in use with attachment plugs connected and identified as extra-duty type.

PART 3 EXECUTION

3.1 EXAMINATION

- A. Verify that outlet boxes are installed in proper locations and at proper mounting heights and are properly sized to accommodate devices and conductors in accordance with NFPA 70.
- B. Verify that wall openings are neatly cut and will be completely covered by wall plates.
- C. Verify that final surface finishes are complete, including painting.
- D. Verify that branch circuit wiring installation is completed, tested, and ready for connection to wiring devices.
- E. Verify that conditions are satisfactory for installation prior to starting work.

3.2 PREPARATION

- A. Provide extension rings to bring outlet boxes flush with finished surface.
- B. Clean dirt, debris, plaster, and other foreign materials from outlet boxes.

3.3 INSTALLATION

- A. Perform work in accordance with NECA 1 (general workmanship) and, where applicable, NECA 130, including mounting heights specified in those standards unless otherwise indicated.

- B. Coordinate locations of outlet boxes provided under Section 26 0533.16 as required for installation of wiring devices provided under this section.
 - 1. Mounting Heights: Unless otherwise indicated, as follows:
 - a. Wall Switches: 48 inches (1200 mm) above finished floor.
 - b. Wall Dimmers: 48 inches (1200 mm) above finished floor.
 - c. Receptacles: 18 inches (450 mm) above finished floor or 6 inches (150 mm) above counter.
 - 2. Orient outlet boxes for vertical installation of wiring devices unless otherwise indicated.
 - 3. Where multiple receptacles, wall switches, or wall dimmers are installed at the same location and at the same mounting height, gang devices together under a common wall plate.
 - 4. Locate wall switches on strike side of door with edge of wall plate 3 inches (80 mm) from edge of door frame. Where locations are indicated otherwise, notify Architect/Engineer to obtain direction prior to proceeding with work.
 - 5. Locate receptacles for electric drinking fountains concealed behind drinking fountain according to manufacturer's instructions.
- C. Install wiring devices in accordance with manufacturer's instructions.
- D. Install permanent barrier between ganged wiring devices when voltage between adjacent devices exceeds 300 V.
- E. Where required, connect wiring devices using pigtails not less than 6 inches (150 mm) long. Do not connect more than one conductor to wiring device terminals.
- F. Connect wiring devices by wrapping conductor clockwise 3/4 turn around screw terminal and tightening to proper torque specified by the manufacturer. Where present, do not use push-in pressure terminals that do not rely on screw-actuated binding.
- G. Unless otherwise indicated, connect wiring device grounding terminal to branch circuit equipment grounding conductor and to outlet box with bonding jumper.
- H. Provide GFCI receptacles with integral GFCI protection at each location indicated. Do not use feed-through wiring to protect downstream devices.
- I. Install wiring devices plumb and level with mounting yoke held rigidly in place.
- J. Install wall switches with OFF position down.
- K. Install vertically mounted receptacles with grounding pole on bottom and horizontally mounted receptacles with grounding pole on left.
- L. Install wall plates to fit completely flush to wall with no gaps and rough opening completely covered without strain on wall plate. Repair or reinstall improperly installed outlet boxes or improperly sized rough openings. Do not use oversized wall plates in lieu of meeting this requirement.
- M. Install blank wall plates on junction boxes and on outlet boxes with no wiring devices installed or designated for future use.
- N. Identify wiring devices in accordance with Section 26 0553.

IA DAS - FDCF Bldg A Water Heater Replacement
Project # 2142301160

3.4 FIELD QUALITY CONTROL

- A. Inspect each wiring device for damage and defects.
- B. Operate each wall switch, wall dimmer, and fan speed controller with circuit energized to verify proper operation.
- C. Test each receptacle to verify operation and proper polarity.
- D. Test each GFCI receptacle for proper tripping operation according to manufacturer's instructions.
- E. Correct wiring deficiencies and replace damaged or defective wiring devices.

3.5 ADJUSTING

- A. Adjust devices and wall plates to be flush and level.

3.6 CLEANING

- A. Clean exposed surfaces to remove dirt, paint, or other foreign material and restore to match original factory finish.

END OF SECTION

Exhibit C Facility Work Requirements

DOC FDCF Unit A Water Heater Replacement
Fort Dodge Correctional Facility
Request for Quote RFQ933200-01

Due Thursday, 4/20/23 at 2:00 PM (CT)

WORK HOUR RESTRICTIONS

1. Allowable work hours are from 7:00 AM to 5:00 PM, Monday through Friday unless arrangements are made in advance.

CONTRACTOR USE OF SITE AND PREMISES

1. Construction Operations: Limited to the mechanical/electrical room in Building A as well as egress to the building and room.
2. Provide access to and from site as required by law and Owner:
 - a. Emergency Building Exits During Construction: Keep all exits required by code open during construction period; provide temporary exit signs if exit routes are temporarily altered.
 - b. Do not obstruct roadways, sidewalks, or other public ways without permission of Owner and permit if required.
3. Facility will be occupied at all times during duration of work. Contractor personnel shall conduct themselves in an agreeable manner at all times. Failure to do so may result in removal from the work site.
4. The contractor shall identify their work zones with a barrier such as caution tape to help delineate the construction areas from public areas.
5. If a crane, lift or other equipment is necessary inside the Facility to perform the work, the mobilization must be coordinated and approved by FDCF Staff and the Construction Manager.
6. Any equipment used inside the perimeter fence must be sized to fit through the sally-port without need to modify the sally-port.

OWNER OCCUPANCY

1. Owner intends to occupy the Project throughout construction.
2. Cooperate with Owner to minimize conflict and to facilitate Owner's operations.
3. Schedule the Work to accommodate Owner occupancy.

RULES FOR CONSTRUCTION WORKERS

1. The staff of the State of Iowa has a responsibility to protect the public by providing a secure environment. All work site rules must always be followed.
2. All construction workers must have a background check completed prior to entering the campus to perform work. There is no cost to the Contractor for them.
3. Hot work permit processes and fire watch, when necessary, will be adhered to for this project.
4. All State properties are tobacco free. No smoking will be permitted or tolerated on campus unless in designated areas.
5. Contractors are permitted access only to the work site and no other areas of the Fort Dodge Correctional Facility.
6. No drugs, alcohol, or firearms are allowed on the work site.
7. Do not leave money, drugs, alcohol, or firearms in your personal vehicle.

8. Company and personal vehicles are to be parked and locked in designated or authorized area of the work.
9. Maintain control of all tools, supplies, and debris always. All tools must always be accounted for and secured at the end of each shift.
10. All vehicles must be locked when unoccupied and the windows left open no more than 1-inch.
11. Do not give anything to residents or take anything from residents; if they offer, inform your supervisor.
12. Ladders and scaffolding must be taken down when not in use and at the end of each shift.
13. Fuel cans are always to be secured.
14. During an emergency, follow the instructions of the security staff.
15. A correctional facility is a somewhat unstable environment and poses certain potential hazards to individuals living, working and visiting within its confines. As a result, compliance with facility policies and procedures, as well as the directives of facility staff is essential. Individuals working inside the facility agree to follow all known policies and procedures, agree to follow the directives of facility staff, and acknowledge responsibility to seek assistance of facility staff if questions or questionable circumstances arise. Individuals working inside the facility also must follow these guidelines:
 - a. Workers must be suitably attired. They will be properly attired as would be expected in a public meeting place. Workers will wear shoes and will not wear miniskirts, shorts, muscle shirts, see-through clothing, halter-tops or clothing made of lycra or spandex material. Split skirts of appropriate length are allowed. Blue chambray shirts are not allowed to be worn with blue jeans. No clothing shall be worn with obscene or lewd slogans, pictures, or words, and similar apparel. All female workers are required to wear a bra and underwear.
 - b. Workers will be required to clear a metal detector scan or other scanning device prior to admittance. Any person who is unable to clear the metal detector scan may be pat searched. All other items such as coats shall be searched electronically and may be manually searched as well. Entrance may be denied if the worker is not willing to submit to a search.
 - c. Workers will be required to bring a list of tools they will be taking inside the facility. These tools will be inventoried going into the facility and again when the worker is leaving the facility. All tools will be accounted for throughout the day.
 - d. For security and safety purposes workers must be escorted by a staff member.
 - e. Cell phones, weapons, and cameras/camcorders are not allowed inside the facility. The foreman will be allowed to have one cell phone.
 - f. Wallets, purses, and billfolds are not allowed inside the facility.
 - g. Tobacco products are not allowed inside the facility.
 - h. All unauthorized items shall be locked in vehicles or secured in the lockers provided in the "K" Reception area.

Exhibit D Sample Certificate of Insurance

DOC FDCF Unit A Water Heater Replacement

Fort Dodge Correctional Facility

Request for Quote RFQ 933200-01

Due Thursday, 4/20/23 at 2:00 PM (CT)

Exhibit E Allowance

DOC FDCF Unit A Water Heater Replacement
Fort Dodge Correctional Facility
Request for Quote RFQ933200-01

Due Thursday, 4/20/23 at 2:00 PM (CT)

Exhibit E Allowance

SIEMENS

Siemens Industry, Inc.
Smart Infrastructure

3/20/2023

Project: FDCF Building A Water Heater Replacement 9332.00

Base Bid Document Information:

- **Architect / Engineering Firm:** Shive-Hattery, Inc.
- **Dated:** 3-08-2023
- **Addenda:** N/A
- **Scope of Work – Section(s):** Drawings & Notes. No Specifications Section for DDC Controls.
- **Performance & Payment Bond:** (Not Included in Bid)

All necessary labor which includes the following:

- Siemens Project Management, to include the following:
 - Project documentation requirements
 - Material ordering and delivery coordination
 - Project Meetings
- Siemens Engineering to provide Siemens standard submittals / record documents:
 - Control installation / wiring diagrams
 - Control & Component Panel layouts
 - Equipment / Instrumentation datasheets
 - Point database.
 - Programming
- Siemens Specialist/Technician to provide standard startup & checkout.
 - Point-to-point check out.
 - Sequence of Operation – verification
 - Graphics
- Siemens to provide Owner training.
- 1-Year parts and labor warranty upon beneficial use of systems

All necessary material which includes the following:

- HVAC DDC Controls and Instrumentation Devices
- Electrical Material for Install of HVAC DDC Controls and Instrumentation Devices
- Ethernet IP BMS Network for control panels and other networked devices

Scope of Work: The following equipment/systems will be controlled and/or monitored by the Siemens Building Management System as described.

- Existing Sequence of Operations through the Siemens DDC System to be modified. Update Graphics to represent new system layout with Plate & Frame Heat Exchangers, separate Storage Tank and On/Off Valves on Heat Exchangers
- Provide new On/Off Valve for Heat Exchanger (Qty 2)
 - Control Valve
- Provide New Temperature Sensors
 - Tank Temperature
 - Hot Water Supply
 - Hot Water Return
- Connect to New Pump (Qty 2)
 - Start/Stop (Relay)
 - Status (Current Switch)
- Alarms:
 - Hot Water Pump Failure (Commanded on, but the status is off)
 - Running in Hand (Commanded off, but the status is on)
- Temperatures to be monitored:
 - Hot Water Supply
 - Hot Water Return
 - Tank Temperature

Siemens Industry, Inc.
Smart Infrastructure
7901 Birchwood Court
Suite 109
Johnston, IA 50131

SIEMENS

Siemens Industry, Inc.
Smart Infrastructure

3/20/2023

Excessive Temperature Failsafe: If tank temperature exceeds 145° F (Adj), the system shall turn off all pumps and close all control valves and issue a high tank temperature alarm until reset by the user.

Low Water Temperature: An alarm shall be sent if the tank water temperature is lower than 120° F (Adj)

Software

- Siemens to extend the following software:
 - Desigo CC
- Siemens to provide development of the following:
 - Graphic

Clarifications:

- The basic layout of the BAS will include main field controller panel's location **TBD**. Each Siemens controller will require field installed 120V power and be connected via a data drop (IP) communications Ethernet cable to the Owner's Network
- 120V power to Siemens temperature control panels and transformer cabinets to be provided and terminated by division 26 contractor.
- Siemens commissioning of the Siemens BMCS is documented per our standard point to point, and sequence of operation testing and documentation.
- All wiring is to be plenum rated cabling except for exposed areas, concealed ceilings, and mechanical / electrical rooms. EMT conduit will be used in these locations.
- Pricing based on utilizing Siemens standard products including commercial grade temperature sensors, valves, actuators, etc.
- All work to be performed during normal working hours (M-F 7:00AM – 5:00PM).

Exclusions





- Electrical Install to provide installation and wiring, to include:
 - HVAC Instrumentation and Control Devices
 - BMS conduit as specified.
 - BMS control and interlock wiring
- Installation of immersion well sensors. (Installation by Mechanical Contractor)
- Installation of control valves. (Installation by Mechanical Contractor)
- Balancing and duct work.
- Smoke duct detectors provided and installed by Electrical Contractor.
- Removing, replacing, cutting, patching, or painting of ceilings or walls
- Asbestos abatement, and work within asbestos areas
- Performance and/or payment bond
- Bid Bond not included.
- Hazardous waste removal not included.
- Building Permits not included.
- Per project aggregate general liability insurance
- Overtime

Budget Allowance: \$18,772.67

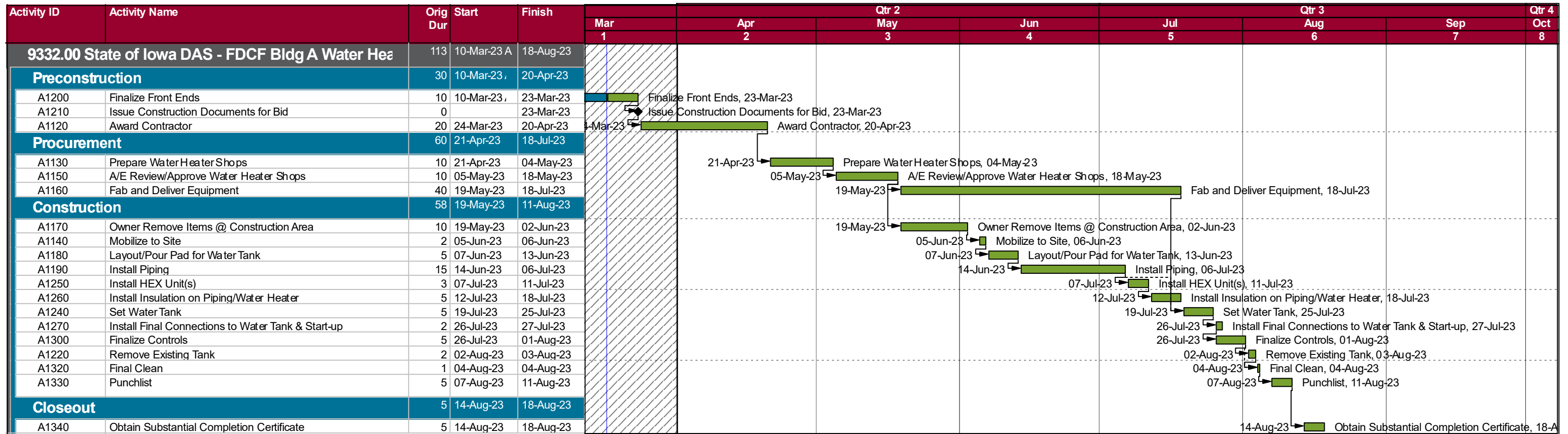
Exhibit F Proposed Schedule
DOC FDCF Unit A Water Heater Replacement
Fort Dodge Correctional Facility
Request for Quote RFQ933200-01

Due Thursday, 4/20/23 at 2:00 PM (CT)



-  Remaining Level of Effort
-  Actual Work
-  Remaining Work
-  Critical Remaining Work
-  Milestone

9332.00 State of Iowa DAS - FDCF Bldg A Water Heater

Current Schedule

24-Mar-23

1 of 1



McGOUGH



Department of
Administrative Services
*Empowering People
Collaboration
Customer Service*