

# IOWA COMMUNICATIONS NETWORK

N. 11TH ST TO MAHASKA COUNTY LAW ENFORCEMENT/911 CENTER/PSAP  
 FIBER INSTALLATION  
 MAHASKA COUNTY, OSKALOOSA, IOWA  
 302 N. 11TH ST TO 214 HIGH AVE E



509 SOUTH GILBERT STREET  
 IOWA CITY, IA 52240  
 PHONE: (319) 338-7557  
 STATE OF IOWA, DEPARTMENT OF LABOR  
 REGULATION NO. 00527328

## LOCATION MAP

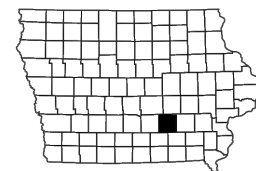
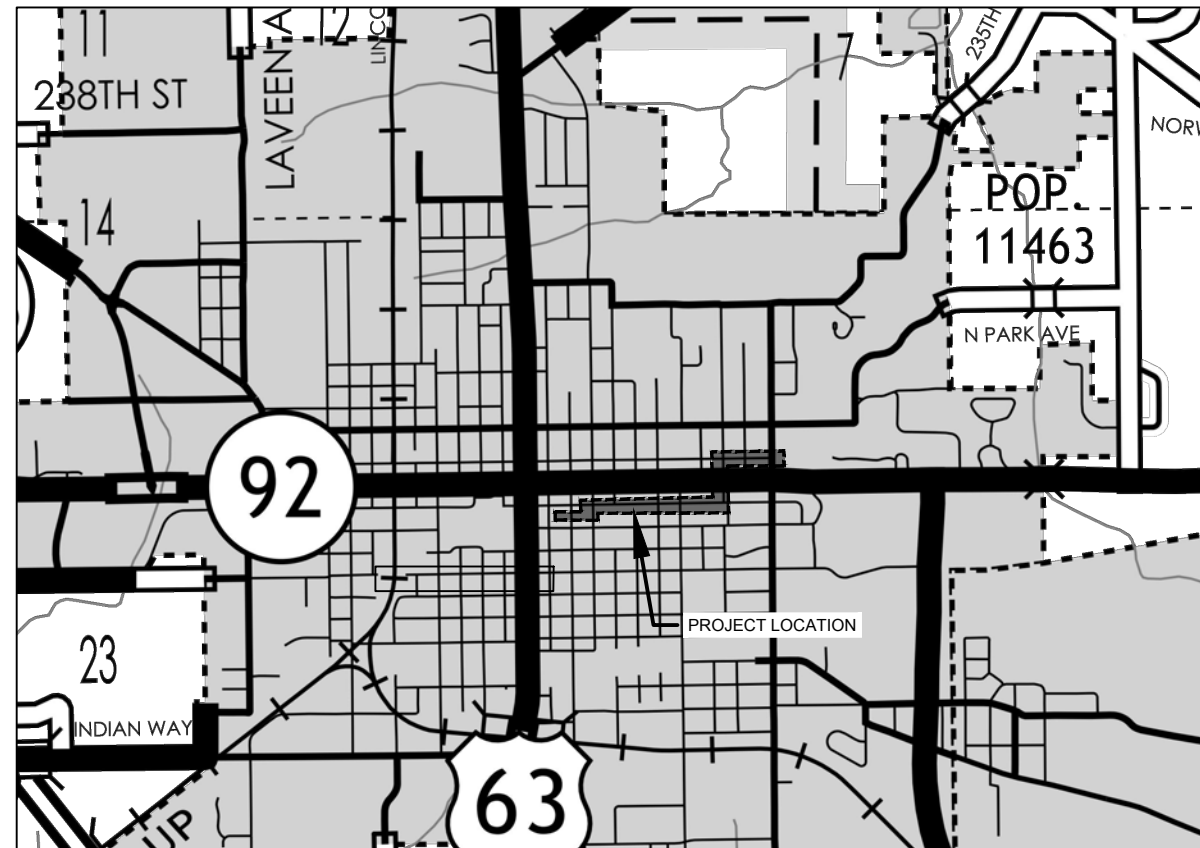

### PROJECT INFORMATION

**SCOPE OF WORK:**

THE ICN INTENDS TO INSTALL A 12 STRAND ARMORED FIBER OPTIC CABLE CONNECTION FROM 302 N. 11TH STREET TO THE MAHASKA COUNTY LAW ENFORCEMENT/911 CENTER AT 214 HIGH AVE E, OSKALOOSA, IA. THIS WILL REQUIRE NEW CONDUIT OF APPROXIMATELY 3,153 FEET AND A TOTAL CABLE FOOTAGE OF APPROXIMATELY 4,343 FEET.

**CONTACT PERSON:**

TIM FLICKINGER  
 IOWA COMMUNICATIONS NETWORK (ICN)  
 PHONE: (515) 725-4699  
 timothy.flickinger@iowa.gov

SANDRA SMITH  
 HBK ENGINEERING  
 509 S. GILBERT STREET  
 IOWA CITY, IA 52240  
 PHONE: (815) 207-1726  
 ssmith@hbkengeering.com

TOM FERGUS  
 IOWA COMMUNICATIONS NETWORK (ICN)  
 PHONE: (515) 971-4008  
 tom@tmfergus.com

JAMEY ROBINSON  
 EMA/911 ADMINISTRATOR  
 PHONE: (641) 672-1209  
 jrobinson@mahaskaema.com

### INDEX OF SHEETS

SHEET	TITLE
1	TITLE SHEET
2	ENGINEER GENERAL NOTES AND LEGEND
3	ICN GENERAL NOTES
4	MATERIALS
CIVIL	
5-10	PLAN SHEETS
11-20	DETAIL SHEETS & TRAFFIC CONTROL

### UTILITY CONTACTS

COMPANY	CONTACT NAME	PHONE	EMAIL
CENTURY LINK (CTLIA01)	TOM STURMER	(720) 578-8090	THOMAS.STURMER@CENTURYLINK.COM
CITY OF OSKALOOSA	COURTNEY RYAN	(641) 673-7472	COURTNEY.RYAN@OSKALOOSAIOWA.ORG
IOWA COMMUNICATIONS NETWORK (ICN)	SHANNON MARLOW	(800) 572-3940	ICNOUTSIDEPLANTIOWAONECALL@IOWA.GOV
IOWA DEPARTMENT OF TRANSPORTATION (IDOT)	NORA LIND	(641) 469-4025	NORA.LIND@IOWADOT.US
IOWA HOSPITALS ASSOCIATION (IHA)	SHANNON MARLOW	(800) 572-3940	ICNOUTSIDEPLANTIOWAONECALL@IOWA.GOV
MAHASKA COMMUNICATION GROUP (MCM)	FRANK HANSEN	(641) 676-1000	SUPPORT@MAHASKA.ORG
MEDIACOM CABLE (TC8)	DARRIN WALKER	(641) 430-0748	RSTALKER@MEDIACOMCC.COM
MIDAMERICAN ELECTRIC (M54E)	JASON SANDIFER	(641) 672-7008	JWSANDIFER@MIDAMERICAN.COM
MIDAMERICAN GAS (M54G)	JASON LOUGH	(641) 683-4171	JELOUGH@MIDAMERICAN.COM
OSKALOOSA MUNICIPAL WATER DEPARTMENT (OKS)	CHAD COON	(515) 673-8476	CHAD.COON@OSKALOOSAWATER.ORG
UNITE PRIVATE NETWORKS (UPN)	JOE KILZER	(816) 425-3556	UPNGIS@UPNFIBER.COM

\*THIS CONTACT LIST IS NOT ALL-INCLUSIVE. CONTRACTOR IS RESPONSIBLE FOR REQUESTING LOCATES OF ALL UTILITIES.

NOTE:  
 CALL 811 FOR LOCATION OF UNDERGROUND TELEPHONE, ELECTRIC, GAS MAINS, CABLE TELEVISION AND OTHER UTILITIES.

EXISTING UNDERGROUND AND OVERHEAD UTILITIES AND DRAINAGE STRUCTURES HAVE BEEN PLOTTED FROM AVAILABLE INFORMATION AND THEREFORE, THEIR LOCATIONS MUST BE CONSIDERED APPROXIMATE ONLY. IT IS THE RESPONSIBILITY OF THE INDIVIDUAL CONTRACTORS TO EXACTLY LOCATE AND PROTECT EACH EXISTING UTILITY BEFORE AND DURING ACTUAL CONSTRUCTION.



ICN OSKALOOSA-PSAP CENTER TO EXISTING ICN HANDHOLE		
1	90% REVIEW	7/27/2020
2	FINAL PLANS	7/29/2020
3		
4		

**IOWA COMMUNICATIONS NETWORK**  
 400 EAST 14TH STREET  
 GRIMES STATE OFFICE BUILDING  
 DES MOINES, IOWA 50319  
 ICN © 2019, COPY WITH PERMISSION

ENGINEER GENERAL NOTES AND LEGEND

ALL CONDUIT AND HANDHOLE INSTALLATIONS, REMOVALS, MODIFICATIONS, AND TEMPORARY WORK SHALL BE DONE ACCORDING TO THE FOLLOWING NON-INCLUSIVE CONDITIONS:

**SECTION 1.0 SCOPE OF WORK**

- 1.01 INSTALLATION DESCRIPTION:  
  
INSTALL CONDUIT AND ALL RELATED APPURTENANCES FOR FIBER OPTIC CABLE INSTALLATION. SEE PLANS FOR EXACT LOCATION, LENGTHS, QUANTITIES, AND DIMENSIONS OF PROPOSE IMPROVEMENTS.
- 1.02 SEE SHEET 4 FOR LOCATION OF ENGINEER'S ESTIMATE OF MATERIALS.
- 1.03 THE CONTRACTOR SHALL PROVIDE ALL MATERIAL, EQUIPMENT, LABOR, INSTALLATION, RESTORATION, UTILITY RELOCATION CHARGES, JOB SITE DELIVERY COSTS AND INCIDENTALS TO COMPLETE THE DESCRIBED OR ILLUSTRATED WORK, UNDER THIS CONTRACT.
- 1.04 ANY CHANGE-ORDER REQUEST MUST BE PRESENTED IN WRITING TO THE OWNER'S REPRESENTATIVE AND APPROVED PRIOR TO PROCEEDING WITH THE REQUESTED CHANGE. DOCUMENTATION CONCERNING ANY AND ALL CHANGE ORDERS WILL BE REDUCED TO FORMAL RECORD, FILED WITH THE OWNER'S REPRESENTATIVE, AND BE MADE AVAILABLE FOR FUTURE REFERENCE.
- 1.05 THE CONTRACTOR SHALL PROVIDE A MINIMUM 48 HOUR ADVANCED NOTICE TO HBK ENGINEERING (319-338-7557) TO SCHEDULE A PRE-CONSTRUCTION WALK THROUGH WITH A HBK ENGINEERING REPRESENTATIVE. THIS WALK THROUGH MUST BE COMPLETED PRIOR TO THE COMMENCEMENT OF ANY WORK WITHIN THE LIMITS OF THIS PROJECT.
- 1.06 THE ENGINEER WILL NOT BE RESPONSIBLE NOR ASSUME ANY LIABILITY FOR NEGLIGENT ACTS OR ERRORS OF OMISSIONS OF ANY CONTRACTOR, ANY SUBCONTRACTOR, OR ANY OF THE CONTRACTOR'S OR SUBCONTRACTORS' AGENTS OR EMPLOYEES OR ANY OTHER PERSONS (EXCEPT ENGINEER'S OWN EMPLOYEES) AT THE PROJECT SITE OR OTHERWISE PERFORMING ANY OF THE WORK OF THE PROJECT. ANY CONTRACTOR OR SUBCONTRACTOR, AS WELL AS THE ENGINEER, WILL BE RESPONSIBLE FOR HIS OWN SAFETY PROGRAM. NEITHER THE PROFESSIONAL ACTIVITIES OF THE ENGINEER, NOR THE PRESENCE OF THE ENGINEER OR HIS OR HER EMPLOYEES AND SUB-CONSULTANTS AT THE CONSTRUCTION SITE, SHALL RELIEVE ANY CONTRACTOR OF HIS OR HER OBLIGATIONS, DUTIES AND RESPONSIBILITIES INCLUDING, BUT NOT LIMITED TO, CONSTRUCTION MEANS, METHODS, SEQUENCE, TECHNIQUES OR PROCEDURES NECESSARY FOR PERFORMING, SUPERINTENDING OR COORDINATING ALL PORTIONS OF THE WORK OF CONSTRUCTION IN ACCORDANCE WITH THE CONTRACT DOCUMENTS AND ANY HEALTH OR SAFETY PRECAUTIONS REQUIRED BY ANY REGULATORY AGENCIES. THE ENGINEER AND HIS OR HER PERSONNEL HAVE NO AUTHORITY TO EXERCISE ANY CONTROL OVER ANY CONSTRUCTION CONTRACTOR OR OTHER ENTITY OR THEIR EMPLOYEES IN CONNECTION WITH ANY HEALTH OR SAFETY PRECAUTIONS.

**SECTION 2.0 MATERIALS**

- 2.01 ALL MATERIALS INSTALLED WITHIN THE LIMITS OF THIS PROJECT SHALL BE IN CONFORMANCE WITH STANDARD RECOMMENDATIONS OF THE NATIONAL ELECTRICAL MANUFACTURER'S ASSOCIATION (NEMA) AND AMERICAN NATIONAL STANDARDS INSTITUTE (ANSI).
- 2.02 ALL TRENCHED CONDUIT, ELBOWS, AND COUPLINGS SHALL BE HDPE SDR 13.5 UNLESS OTHERWISE NOTED. ALL BORED CONDUIT AND COUPLINGS SHALL BE HDPE SDR-13 UNLESS OTHERWISE NOTED.
- 2.03 JOB SITE MATERIAL WILL BE DELIVERED TO AND MAINTAINED AT THE STREET WORK AREAS IN A WELL MANAGED MANNER, TO MINIMIZE CONGESTION OR INCONVENIENCE TO OTHER WORKERS, OR CONTRACTORS WORKING UNDER ALTERNATE PERMITS.

**SECTION 3.0 GENERAL NOTES**

- 3.01 CONTRACTOR IS ADVISED TO READ ALL NOTES ON DRAWINGS, CAREFULLY.
- 3.02 THE CONTRACTOR SHALL VERIFY EXISTING STREET RIGHTS OF WAY TO THE EXTENT NECESSARY TO VERIFY PROPOSED WORK REMAINS WITHIN THESE RIGHTS OF WAY AND DOES NOT INFRINGE ON PRIVATE PROPERTY NOT OWNED BY THE OWNER.
- 3.03 SCALE FOR DRAWINGS IS FOR GENERAL INFORMATION ONLY. LOCATIONS AND DIMENSIONS SHALL BE TAKEN AS SHOWN AND THE DRAWINGS SHALL NOT BE SCALED.
- 3.04 CONTRACTOR SHALL COORDINATE ALL WORK WITH ALL PUBLIC AND PRIVATE UTILITIES AS WELL AS CITY AND STATE AGENCIES.
- 3.05 INSTALL CONDUIT MINIMUM OF 10'-0" BELOW ALL WATERWAYS AND CULVERT CROSSINGS. CONTRACTOR TO VERIFY CULVERT DEPTH PRIOR TO CONDUIT INSTALLATION.
- 3.06 NUMEROUS ELEVATION CHANGES. TOPOGRAPHY LINES SHOWN ON DRAWING FOR REFERENCE ONLY.
- 3.07 DUE TO EXISTING FORESTED AREAS, SOME TREE REMOVAL AND TRIMMING REQUIRED FOR CONDUIT OR HANDHOLE INSTALLATION WITHIN THE RIGHT-OF-WAY.
- 3.08 RIGHT OF WAY LOCATIONS ARE APPROXIMATE. FIBER INSTALLATION 6'-0" MINIMUM OFF RIGHT-OF-WAY.

**SECTION 4.0 SAFETY**

- 4.01 CONTRACTOR SHALL TAKE ALL NECESSARY SAFETY PRECAUTIONS TO PROTECT UTILITIES, PEDESTRIANS, WORKERS AND VEHICULAR TRAFFIC. THE CONTRACTOR SHALL PROVIDE TEMPORARY FENCES, BARRICADES, ETC. AS REQUIRED TO PROTECT ADJACENT PROPERTY AND THE PUBLIC DURING ALL PHASES OF CONSTRUCTION.
- 4.02 THE CONTRACTOR SHALL PROVIDE ALL TEMPORARY BARRICADES, SIGNAGE, WARNING LIGHTS AND OTHER DEVICES AND KEEP ALL TRAFFIC CONTROL OPERATIONAL 24 HOURS A DAY AT ALL OPEN TRENCH LOCATIONS AND AT LOCATIONS WHICH DO NOT HAVE A FINISHED SURFACE OR ROAD PLATES.
- 4.03 THE CONTRACTOR SHALL COORDINATE INGRESS AND EGRESS TO ADJACENT PROPERTIES AND/OR CONSTRUCTION AFFECTED BY THE PROPOSED WORK.

**SECTION 5.0 EXISTING UTILITIES**

- 5.01 EXISTING CONDITIONS, STRUCTURES, UTILITIES AND SURFACE FEATURES SHOWN WERE OBTAINED FROM UTILITY ATLASES AND FROM DRAWINGS FURNISHED BY THE VARIOUS UTILITIES AND ARE ASSUMED TO BE ACCURATE AND CORRECT. THE CONTRACTOR SHALL PERFORM HIS OWN SURVEY AND VERIFY ALL EXISTING CONDITIONS AND DIMENSIONS OF EXISTING STRUCTURES PRIOR TO STARTING ANY WORK.
- 5.02 FOR BORED INSTALLATIONS, THE CONTRACTOR SHALL PERFORM TEST HOLES AT ALL UTILITY CROSSINGS TO VERIFY THE LOCATION AND ELEVATION OF ALL UTILITIES PRIOR TO ANY EXCAVATION, AND TO LOCATE ANY POSSIBLE OBSTRUCTIONS. ALL TEST HOLES SHALL BE CONSIDERED INCIDENTAL TO THE CONTRACT. FILL ALL BORE HOLES WITH SAND. FILL THE TOP WITH 6-INCHES OF TOPSOIL.
- 5.03 FOR TRENCHED INSTALLATIONS, THE CONTRACTOR SHALL PERFORM TEST HOLES PER PLAN OR AS DEEMED NECESSARY TO VERIFY THE LOCATION AND ELEVATION OF ALL UTILITIES PRIOR TO ANY EXCAVATION, AND TO LOCATE ANY POSSIBLE OBSTRUCTIONS. ALL TEST HOLES SHALL BE CONSIDERED INCIDENTAL TO THE CONTRACT.
- 5.04 THE CONTRACTOR SHALL FIELD VERIFY LOCATIONS OF ALL OVERHEAD OBSTRUCTIONS PRIOR TO THE COMMENCEMENT OF WORK.
- 5.05 EXISTING UTILITIES ARE SHOWN AT THEIR APPROXIMATE LOCATION. THE CONTRACTOR SHALL CONTACT IOWA ONE CALL AT 1(800)-292-8989 A MINIMUM OF 48 HOURS (EXCLUDING WEEKENDS AND GOVERNMENT HOLIDAYS) PRIOR TO COMMENCEMENT OF ANY PAVEMENT CUTS OR EXCAVATION TO REQUEST LOCATING AND MARKING OF EXISTING UTILITIES PRIOR TO PERFORMING ANY EXCAVATION WORK IN OR AROUND ANY UTILITY.
- 5.06 ALL EXCAVATION WORK NEAR AND AROUND EXISTING STRUCTURES AND UTILITIES SHALL BE BY HAND METHOD.
- 5.07 ALL DISCREPANCIES SHOULD BE REPORTED TO ENGINEER OF RECORD AT HBK ENGINEERING (319-338-7557). ANY QUESTIONS OR COMMENTS THE CONTRACTOR MAY HAVE ARE TO BE DISCUSSED WITH THE OWNER AND ENGINEER PRIOR TO CONSTRUCTION.
- 5.08 FURTHER, THE CONTRACTOR SHALL RECORD THE LOCATION AND ELEVATION OF ALL UTILITIES ENCOUNTERED, AND INSTALLATION OF NEW WORK, AS THE WORK PROGRESSES AND SHALL PREPARE RECORD DRAWINGS (RED-LINES) BASED ON HIS RECORDS. AS PART OF THE RECORD DRAWINGS, CONTRACTOR SHALL ALSO PROVIDE HORIZONTAL AND VERTICAL CONFIGURATION OF CONDUITS WHERE MULTIPLE CONDUITS ARE INSTALLED. THESE RECORDS TO BE SUPPLIED TO HBK ENGINEERING, LLC AT COMPLETION OF WORK.
- 5.09 AT SEWER DRAINS FROM HOMES OR OTHER BUILDINGS, IF THERE IS INTERFERENCE, REPLACE INKIND. IN ALL CASES WHERE SEWER WORK IS DONE, A PERMIT SHOULD BE OBTAINED AND A SEWER INSPECTOR SHOULD BE PRESENT DURING THE WORK.
- 5.10 CONTRACTOR SHALL SUPPORT ALL WATER MAINS IN EXCESS OF 12" IN DIAMETER WITH A PERMANENT TYPE OF STRUCTURE UNLESS OTHERWISE NOTIFIED BY THE WATER DEPARTMENT, AND IS INCLUDED IN COST FOR DOING THE WORK. AT NO TIME DURING CONSTRUCTION SHALL WATER MAINS GO UNSUPPORTED FOR A SPAN GREATER THAN 8'-0".
- 5.11 CONTRACTOR RESPONSIBLE FOR OBTAINING AND PROVIDING REVIEW AND DESIGN OF ANY AND ALL TEMPORARY UTILITY SUPPORT SYSTEMS PRIOR TO CONSTRUCTION.
- 5.12 CONTRACTOR SHALL NOTIFY THE ELECTRICAL UTILITY COMPANY IN SITUATIONS WHERE STEEL PIPE CONDUCTOR IS NICKED DURING EXCAVATION. ELECTRICAL UTILITY COMPANY WILL EVALUATE THE EXTENT OF THE DAMAGE SO AS TO DETERMINE WHETHER REPAIR IS REQUIRED PRIOR TO BACKFILL AND GRADE SURFACE RESTORATION.











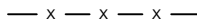

































**SECTION 6.0 WORK**

- 6.01 NO STORAGE OF EQUIPMENT OR MATERIALS IN THE ROADWAY IS PERMITTED UNLESS THE CONTRACTOR OBTAINS WRITTEN PERMISSION FROM THE CITY, STATE, AND/OR GOVERNING BODY.
- 6.02 THE CONTRACTOR SHALL MARK ALL OPENINGS ON THE SURFACE PRIOR TO THE COMMENCEMENT OF EXCAVATION. ALL OPENINGS ON PAVED SURFACES SHALL BE SAW CUT PRIOR TO REMOVAL OF PAVEMENT.
- 6.03 CONTRACTOR RESPONSIBLE FOR OBTAINING AND PROVIDING REVIEW AND DESIGN OF ANY AND ALL SHORING SYSTEMS PRIOR TO CONSTRUCTION.
- 6.04 CONTRACTOR SHALL ASSUME ALL ELECTRICAL CABLES ARE ENERGIZED AND SHALL BE SUPPORTED SO AS NOT TO STRESS ANY PORTION OF THE CABLE.
- 6.05 CONTRACTOR SHALL PROVIDE APPROPRIATE ENGINEERED DE-WATERING MEASURES, IF NECESSARY, TO ENSURE GROUNDWATER TABLE REMAINS AT A DEPTH BELOW THE BASE OF THE EXCAVATION AT ALL TIMES DURING EXCAVATION, INSTALLATION AND BACKFILLING OPERATIONS.
- 6.06 THE ENGINEER SHALL BE NOTIFIED FOR RESOLUTION OF SITUATIONS WHERE CONDUIT DEPTH BELOW GRADE DEVIATES BY MORE THAN 3" AS CURRENTLY SHOWN ON PLAN/PROFILE DRAWINGS.
- 6.07 THE ENGINEER SHALL ALSO BE NOTIFIED FOR DISPOSITION OF SITUATIONS WHERE THE CONDUIT CANNOT MAINTAIN SEPARATIONS PER PLAN.

**SECTION 7.0 RESTORATION**

- 7.01 THE CONTRACTOR SHALL OBTAIN A PERMIT TO PERFORM ALL RESTORATION WORK IN THE CONTRACTOR'S NAME. ALL PAVING SHALL BE COMPLETED WITHIN 15 WORKING DAYS AFTER EXCAVATION IS BACKFILLED UNLESS OTHERWISE ARRANGED IN ADVANCE WITH GOVERNING AGENCY.
- 7.02 CONTRACTOR SHALL BREAK OUT SIDEWALK, DRIVEWAY, CURB AND GUTTER, PAVEMENT AND RESTORE TO PERMANENT CONDITION. CONTRACTOR TO CONFORM CONCRETE TO SHAPE, COLOR, FINISH, AND TEXTURE OF EXISTING SIDEWALKS, CURB AND GUTTER.
- 7.03 THE CONTRACTOR IS RESPONSIBLE FOR THE RESTORATION OF THE AREAS DISTURBED BY CONSTRUCTION ACTIVITIES. CONTRACTOR TO PAY ALL FEES AND OBTAIN ALL PERMITS FOR RESTORATION.
- 7.04 THE CONTRACTOR IS TO RESTORE ALL DAMAGED STRUCTURES AND UTILITIES TO THE SATISFACTION OF THE CITY AND THE FACILITY OWNER, IN THE EVENT THAT DAMAGE OCCURS.

**LEGEND**

- FENCE 
- EXISTING ROW LINE 
- EXISTING FIBER OPTIC LINE 
- EXISTING OVERHEAD LINE 
- EXISTING STORM DRAIN 
- EXISTING ELECTRIC (BURIED) 
- EXISTING GAS LINE 
- EXISTING STORM SEWER 
- EXISTING SANITARY SEWER 
- EXISTING WATER LINE 
- EXISTING ICN FIBER 
- EXISTING ICN (AERIAL) 
- EXISTING ICN CONDUIT 
- TO BE ABANDONED 
- PROPOSED ICN FIBER 
- PROPOSED AERIAL 
- PROPOSED ICN CONDUIT 
- CENTERLINE OF ROAD 
- EXISTING WATERWAY BOUNDARY 
- PROPOSED ICN HANDHOLE 
- EXISTING ICN HANDHOLE 
- PROPOSED HANDHOLE (BY OTHERS) 
- BORE PIT 
- EXISTING STORM MANHOLE 
- EXISTING STORM INLET 
- EXISTING SANITARY MANHOLE 
- EXISTING SANITARY CLEAN OUT 
- EXISTING FIBER OPTIC MANHOLE 
- EXISTING FIBER OPTIC HANDHOLE 
- EXISTING COMMUNICATIONS MANHOLE 
- EXISTING COMMUNICATIONS HANDHOLE 
- EXISTING COMMUNICATIONS PEDESTAL 
- EXISTING ELECTRIC MANHOLE 
- EXISTING ELECTRIC TRANSFORMER 
- EXISTING ELECTRIC PEDESTAL 
- EXISTING ELECTRIC HANDHOLE 
- EXISTING UTILITY POLE 
- EXISTING GUY ANCHOR 
- EXISTING LIGHT POLE 
- EXISTING WATER MANHOLE 
- EXISTING WATER VALVE 
- EXISTING MONITORING WELL 
- EXISTING FIRE HYDRANT 
- EXISTING NATURAL GAS MANHOLE 
- EXISTING NATURAL GAS VALVE 
- EXISTING TREE 



ICN OSKALOOSA—PSAP CENTER TO EXISTING ICN HANDHOLE		<b>hbk icn</b>	
1	90% REVIEW	7/27/2020	<b>IOWA COMMUNICATIONS NETWORK</b> 400 EAST 14TH STREET GRIMES STATE OFFICE BUILDING DES MOINES, IOWA 50319 ICN © 2019, COPY WITH PERMISSION
2	FINAL PLANS	7/29/2020	
3			
4			

ICN GENERAL NOTES

**STANDARD INSTALLATION REQUIREMENTS:**

**GENERAL REQUIREMENTS:**

1. THE CONTRACTOR SHALL POTHOLE ALL EXISTING UTILITIES.
2. PROVIDE THE OWNERS OF ANY NATURAL GAS UTILITY 48 HOURS ADVANCE NOTICE THAT WORK IS SCHEDULED IN THE VICINITY OF THEIR LINES/MAINS SO THAT THEY CAN PROVIDE STANDBY AND PROTECT SERVICES.
3. MAINTAIN PROOF OF NOTIFICATION TO AND RECEIPT OF NOTIFICATION BY THE GAS UTILITY.
4. PERMITS AND COORDINATION
  - 4.1. SECURE ALL NECESSARY STATE AND LOCAL (CITY, COUNTY, ETC.) PERMITS, PUBLIC OR PRIVATE EASEMENTS, FACILITY PERMITS, USAGE PERMITS, AND ANY OTHER PERMIT REQUIRED BY AN AUTHORITY HAVING JURISDICTION (AHJ). ALL CONTRACTORS AND SUBCONTRACTORS MUST BE LICENSED AND BONDED WITH THE CITY OF CLEAR LAKE.
  - 4.2. ICN WILL OBTAIN AND PROVIDE COPIES OF IDOT PERMITS.
  - 4.3. IF PERMITS ARE REQUIRED TO BE IN THE NAME OF THE OWNER RATHER THAN THE CONTRACTOR, THE CONTRACTOR SHALL PREPARE THE PERMIT FOR THE OWNER'S SIGNATURE.
  - 4.4. COORDINATE INSTALLATION WITH ALL OWNERS AND AHJ OVER THE ROUTE, THE FIBER, RIGHT-OF-WAY AND BUILDINGS IN WHICH END POINTS WILL BE LOCATED.
  - 4.5. FAILURE TO COORDINATE WITH THE AHJ AND TO OBTAIN ALL NECESSARY PERMITS IS AT THE PERIL OF THE CONTRACTOR.
  - 4.6. RIGHT-OF-WAY PERMIT FEES ARE AN AUTHORIZED EXTRA ABOVE THE QUOTED BID PRICE. EXCAVATION PERMITS SHALL BE BY THE CONTRACTOR.
  - 4.7. ENSURE ALL FACILITIES ARE PLACED WITHIN THE PUBLIC RIGHT-OF-WAY.
5. ENSURE THAT PERSONNEL WORKING IN THE ROW ARE EQUIPPED WITH AND USE PROPER SAFETY EQUIPMENT AND ATTIRE.
6. ALL TOOLS AND TEST EQUIPMENT REQUIRED TO DO A PROJECT SHALL BE PROVIDED BY THE CONTRACTOR OR ITS SUBCONTRACTOR(S). SECURITY OF TOOLS AND TEST EQUIPMENT SHALL BE THE RESPONSIBILITY OF EACH WORKER. THE ICN SHALL NOT BE RESPONSIBLE FOR THE SECURITY OF ANY PROPERTY LEFT ON ICN'S PROPERTY OR ON PROPERTY CONTROLLED BY THE ICN OR THE STATE OF IOWA.
7. CONTRACTOR SHALL BE RESPONSIBLE FOR INSTRUCTING ITS EMPLOYEES IN SAFETY MEASURES CONSIDERED APPROPRIATE FOR THE JOB. IN ADDITION, THE CONTRACTOR SHALL NOT PERMIT PLACING OR USE OF TOOLS OR MATERIALS IN TRAFFIC LANES OR OTHER LOCATIONS. THE TOOLS OR MATERIALS SHALL NOT BE PLACED IN SUCH A MANNER SO AS TO CREATE SAFETY HAZARDS TO STATE EMPLOYEES, CONTRACTING AGENCY EMPLOYEES, THE PUBLIC OR THEMSELVES.
8. EXCAVATIONS AND TRENCHES: THE ICN REQUIRES ALL OPEN EXCAVATIONS OR TRENCHES TO BE MONITORED AND ATTENDED TO DURING CONSTRUCTION PER. THE ICN REQUIRES ALL OPEN EXCAVATIONS AND TRENCHES BACKFILLED THE SAME DAY. IF THE CONTRACTOR IS REQUIRED TO LEAVE AN EXCAVATION OR TRENCH OPEN, THEN THE CONTRACTOR SHALL PROPERLY FENCE AND/OR COVER THE EXCAVATION FOR SAFETY. CONTRACTOR SHALL FOLLOW ALL OSHA REQUIREMENTS FOR EXCAVATION AND TRENCH SAFETY.
9. CONTRACTOR AND ITS EMPLOYEES SHALL COMPLY WITH ALL OSHA REGULATIONS. THE CONTRACTOR SHALL COMPLY WITH ALL APPLICABLE STATE AND FEDERAL LAWS.
10. CONTRACTOR SHALL COMPLY WITH ALL IOWA ONE CALL REQUIREMENTS AS PROVIDED BY IOWA CODE, CHAPTER 480.
11. PROVIDE ALL LABOR AND SUPERVISION FOR THE PROJECT.
12. PROVIDE AND INSTALL MATERIALS NEEDED TO RESULT IN A FULLY FUNCTIONAL SYSTEM MEETING ICN STANDARDS, WHETHER OR NOT THE MATERIALS OR METHODS ARE SPECIFICALLY MENTIONED IN THIS DOCUMENT. SEE THE LIST OF ICN-FURNISHED MATERIALS.
13. INSTALL CABLE ROUTE MARKERS FURNISHED BY ICN. WHERE POSSIBLE, INSTALL MARKERS ADJACENT TO POLES, BUILDINGS OR IN OTHER PROTECTED AREAS.
14. A COPY OF THIS SCOPE OF WORK AND THE ENGINEERING PLAN FOR THIS PROJECT SHALL BE ON SITE AND AVAILABLE ANY TIME WORK IS BEING PERFORMED. FAILURE TO HAVE THE REQUIRED DOCUMENTS ON SITE MAY RESULT IN ICN REQUIRING THE CONTRACTOR TO STOP WORKING UNTIL THE REQUIRED DOCUMENTS ARE ON-SITE.
15. SUBCONTRACTORS SHALL MEET THE SAME QUALIFICATIONS STATED FOR CONTRACTORS. CONTRACTOR SHALL OBTAIN APPROVAL OF THE CONTRACTING AGENCY'S PROJECT MANAGER PRIOR TO USING A SUBCONTRACTOR ON ANY PROJECT.
16. RESTORE ALL DAMAGE TO PRIVATE PROPERTY, RIGHT-OF-WAY, ICN PROPERTY, AND ANY OTHER PROPERTY DAMAGED IN THE COURSE OF THE WORK.
  - 16.1. ANY DISRUPTION OF GRASS IN AN INDIVIDUAL'S YARD OR IN A PRIVATE MAINTAINED AREA OF THE PUBLIC RIGHT OF WAY (THE AREA BETWEEN THE SIDEWALK AND THE STREET CURB) MUST BE RESTORED THROUGH RE-SODDING. ANY DISRUPTION OF THE GRASS IN THE MEDIAN WAY OR AN UNIMPROVED SHOULDER MUST BE RESTORED EITHER THROUGH RE-SODDING OR RE-SEEDING AS REQUIRED BY THE ROW OWNER.
  - 16.2. AREAS SHALL BE RESTORED TO ORIGINAL OR BETTER CONDITION.
  - 16.3. DIRT SHALL BE MECHANICALLY COMPACTED AROUND HANDHOLES AND PITS.
  - 16.4. LAWNS SHALL BE SODDED WITH LIKE GRASS.
  - 16.5. CONTRACTOR IS RESPONSIBLE FOR WATERING THE SOD UNTIL IT HAS KNITTED TO THE GROUND BENEATH.
  - 16.6. ALL DEBRIS SHALL BE REMOVED FROM THE CONSTRUCTION AREAS INCLUDING BUT NOT LIMITED TO: CONSTRUCTION MATERIALS, TRASH, LARGE OBJECTS OR STONES WITHIN BACKFILLED AREAS, ETC.

**DUCT INSTALLATION REQUIREMENTS**

1. HDPE DUCT SHALL BE NO LESS THAN 36-42 INCHES DEEP.
2. DUCT SHALL BE INSTALLED IN THE PUBLIC RIGHT-OF-WAY.
3. WHEN CROSSING A HIGHWAY IN DOT RIGHT-OF-WAY, DUCT SHALL BE NO LESS THAN 48 INCHES BELOW GRADE UNDER THE ROADWAY AND SHOULDERS. HDPE MAY BE USED UNDER THE ROADWAY AND SHOULDERS IF INSTALLED AT A MINIMUM DEPTH OF 48".
4. SHOULD IT BE NECESSARY TO CROSS PRIVATE PROPERTY, THE CONTRACTOR MAY APPLY TO THE ICN FOR AN EXCEPTION, AND REQUEST PERMISSION TO SECURE AN EASEMENT. THE EASEMENT IS REQUIRED TO BE IN THE NAME OF ICN AND THE CONTRACTOR SHALL HAVE THE EASEMENT PREPARED BY A LAND SURVEYOR LICENSED IN THE STATE OF IOWA. CONTRACTOR SHALL BE RESPONSIBLE FOR ALL FEES UNLESS PREVIOUSLY AUTHORIZED BY THE ICN.
5. AT THE CONCLUSION OF THE PROJECT, PROVIDE AND LEAVE A PULL ROPE IN ALL DUCTS, CONDUITS AND PATHWAYS, INCLUDING INDOOR, OUTDOOR, NEW AND EXISTING.
6. DIRT SHALL BE MECHANICALLY COMPACTED AT ALL DUCT SPLICES, BORE PITS AND AROUND HANDHOLES.
7. GROUND SHALL BE RESTORED TO THE CONDITION FOUND PRIOR TO CONSTRUCTION AND DEBRIS REMOVED PRIOR TO SODDING OR SEEDING.
8. ALL CONDUITS SHALL BE PLUGGED VIA DUCT SEAL OR OTHER METHOD UPON COMPLETION OF CABLE INSTALLATION.
9. IF SCHEDULE 40 PVC CONDUIT IS UTILIZED, ALL ANGLES (45, 90 DEGREE OR OTHER) REQUIRE FITTINGS TO LONG SWEEP TO ACCOMMODATE MINIMUM CABLE BEND RADIUS.
10. THE ICN REQUIRES PICTURES BY THE CONTRACTOR AND/OR ON-SITE INSPECTION BY ICN STAFF PRIOR TO COMPLETION OF THE PROJECT WHERE PIPE AND FITTINGS ARE NOT EXPOSED; I.E. UNDERGROUND, BEHIND A WALL, ETC.

**HANDHOLE REQUIREMENTS**

1. INSTALL HANDHOLES SO THAT THE LID IS LEVEL AND FLUSH WITH THE SURROUNDING NATURAL GRADE. THE LID SHALL NOT EXTEND ABOVE THE SURROUNDING NATURAL GRADE.
2. PROVIDE ¼" OPENING HARDWARE CLOTH TYPE SCREEN WIRE BELOW THE HANDHOLE.
3. PROVIDE 5-6 INCHES OF ¾" CRUSHED ROCK BELOW THE HANDHOLE. ROCK SHALL BE COMPACTED. GRAVEL SHALL EXTEND A MINIMUM OF 6 INCHES BEYOND THE OUTSIDE WALLS OF THE HANDHOLE. DO NOT USE PEA GRAVEL OR OTHER ROUND STONE.
4. DO NOT PLACE GRAVEL INSIDE HANDHOLE ABOVE THE HARDWARE CLOTH.
5. CONDUIT SHALL EXTEND A MINIMUM OF 6" ABOVE THE HARDWARE CLOTH/GRAVEL.
6. FAILURE OF THE CONTRACTOR TO INSTALL HANDHOLES AS SPECIFIED WILL CAUSE THE CONTRACTOR TO RETURN AND RE-INSTALL THE HANDHOLE ACCORDING TO THIS SPECIFICATION BEFORE PAYMENT FOR THE PROJECT IS MADE.
7. HANDHOLE INSTALLATIONS SHALL FOLLOW ICN STANDARD TYPICAL INSTALLATION; SEE TYPICAL DRAWING.

**FIBER INSTALLATION REQUIREMENTS**

1. INSTALL FIBER ACCORDING TO INDUSTRY "BEST PRACTICES".
2. THE CONTRACTOR SHALL NOT VIOLATE THE MANUFACTURER'S MINIMUM INSTALLATION BEND RADIUS WHEN THE CABLE IS UNDER TENSION, OR THE MINIMUM INSTALLED BEND RADIUS.
3. TO PREVENT EXCEEDING THE MANUFACTURER'S MAXIMUM PULLING TENSION DURING INSTALLATION OF THE FIBER OPTIC CABLE, THE CONTRACTOR SHALL USE A "BREAK-AWAY" PULLING SWIVEL WHEN INSTALLING CABLE.
4. THE "BREAK-AWAY" FUNCTION SHALL ACTIVATE AT OR BELOW THE MAXIMUM PULLING TENSION SPECIFIED BY THE CABLE MANUFACTURER.
5. THE CONTRACTOR SHALL TEST ALL STRANDS OF THE FIBER, ON THE REEL, PRIOR TO BEGINNING FIBER INSTALLATION. CONFIRM THAT ALL STRANDS MEET MANUFACTURER'S LOSS SPECIFICATIONS.
6. THE CONTRACTOR SHALL FIELD VERIFY ALL LENGTHS AND EXISTING CONDITIONS PRIOR TO STARTING CONSTRUCTION.
7. SLACK LOOPS IN HANDHOLES SHALL BE COILED, INSTALLED, AND SECURED TO AVOID DAMAGE TO THE COIL AND NOT INTERFERE WITH LIDS.
8. SLACK LOOPS AT SPLICES SHALL BE COILED TO MATCH THE EXISTING FIBER CABLE TAILS AND ALLOWANCE FOR SPLICE PREPARATION.
9. ICN FIBER IN ALL HANDHOLES SHALL BE LABELED WITH ICN WRAP AROUND CABLE TAGS OR OTHER LABELED CABLE TAGS.

**BUILDING ENTRY REQUIREMENTS**

1. WEATHER-SEAL ALL PENETRATIONS.
2. USE MORTAR OR SIMILAR CEMENT TO SEAL PENETRATION OF BRICK OR CEMENT BLOCK.
3. FIRESTOP PENETRATIONS OF ANY FIRE-RATED FLOOR, WALL OR CEILING.
4. REPLACE THE FIRESTOP MATERIAL IN ANY EXISTING FIRESTOPPED PENETRATION USED BY THE CONTRACTOR.
5. ALL OUTDOOR CONDUITS, OF ANY LENGTH, SHALL BE GALVANIZED IRON PIPE (GIP). EMT, PVC AND PLASTIC ARE PROHIBITED.
6. IMMEDIATELY UPON INSTALLATION, SEAL THE ENDS OF ALL DUCTS WITH DUCT SEAL OR EXPANSION FOAM TO PREVENT SILTATION OR FILLING WITH MOISTURE. THIS APPLIES TO BOTH NEW AND EXISTING DUCTS.
7. AT THE CONCLUSION OF THE PROJECT, ENSURE THAT A PULL ROPE IS LEFT IN ALL PATHWAYS, BOTH INSIDE AND OUTSIDE, NEW AND EXISTING.

**LOCATE FACILITY REQUIREMENTS**

1. TRACER WIRE SHALL BE CONTINUOUS.
2. SPLICES IN THE TRACER WIRE ARE NOT ALLOWED. IF TRACER WIRE IS ACCIDENTALLY SEVERED, REQUEST PERMISSION FROM ICN TO SPLICE.
3. SPLICE ONLY IN HANDHOLES.
4. USE EITHER AN EPOXY SPLICE KIT, SCOTCH 3M 3832 OR A MOLEX PERMASEAL BUTT SPLICE. 10-12 GA. SPLICE MATERIALS SHALL BE DESIGNED FOR UNDERGROUND APPLICATIONS.
5. LEAVE THE WIRE SPLICE VISIBLE IN THE HANDHOLE.
6. ROUTE A GROUND WIRE FROM THE GROUND INSIDE THE BUILDING, THROUGH THE ENTRY TO THE TII 163 TERMINAL.
7. SECURE ALL RISER CONDUITS WITH 3 EACH TWO-HOLE CONDUIT STRAPS.
8. WIRE THE PEDESTAL/TERMINAL SO THAT LOCATES MAY BE PERFORMED IN ANY DIRECTION AND FROM THE FAR END.
9. DO NOT LEAVE ANY EXPOSED TRACER WIRE OR GROUND WIRE.
10. PERMANENTLY GROUND THE TRACER WIRE AT THE HANDHOLE ON THE FURNISHED GROUND ROD.
11. AT THE CONCLUSION OF THE PROJECT LEAVE THE TRACER WIRE SHIELD SHORTED TO GROUND IN THE LOCATE TERMINAL.
12. USE TRACER WIRE THAT IS RATED FOR DIRECT BURIAL WHERE REQUIRED. TRACER WIRE SHALL BE #12 AWG, SOLID HF CCS 30 MIL HDPE HIGH FLEX TRACER WIRE: EITHER SOLID COPPER OR COPPER CLAD STEEL.
13. LABEL ALL WIRES IN THE LOCATE TERMINAL/PEDESTAL/TRIVIEW. (I.E. "GROUND", "FACING DMACC", "FACING NORTH" ETC.)
14. FAILURE TO LABEL THE LOCATE WIRES WILL CAUSE THE CONTRACTOR TO RETURN AND PROPERLY LABEL THE WIRES BEFORE PAYMENT FOR THE PROJECT IS MADE.
15. BOND TRACER WIRE(S) WITHIN SPLICE ENCLOSURES UTILIZING A 3M 4460-D\FO SHIELD BONDING KIT.
16. ROUTE TRACER WIRE(S) OUT OF SPLICE ENCLOSURE THROUGH A SINGLE PORT UTILIZING A FOSC CLOSURE SEALING KIT.
17. AT SPLICE LOCATIONS WITH NO LOCATE PEDESTAL, TRACER WIRES SHALL BE BONDED TOGETHER, WITHIN THE SPLICE ENCLOSURE.
18. AT EACH END OF ANY TRACER WIRE, USE APPROPRIATE-SIZED RING TERMINAL (CRIMP) CONNECTORS USING APPROPRIATE CRIMP TOOL; OR CREATE A WIRE EYELET AS PER TYPICAL INSTALLATION OF TRI-VIEW LOCATE PEDESTAL DETAIL.

**DELIVERABLES/ACCEPTANCE:**

1. CONTRACTOR SHALL PROVIDE CONSTRUCTION REDLINE AS-BUILTS WITH:
  - 1.1. OFFSETS TO FIXED OBJECTS TO THE CABLE/CONDUIT RUNNING LINE, HANDHOLES AND NEW FACILITIES.
  - 1.2. METER MARKS OF CABLE INSTALLATIONS AT HANDHOLE ENTRY/EXIT, SPLICE LOCATIONS, BUILDING ENTRIES, ETC.
  - 1.3. DEPTHS OF CABLE AND/OR CONDUIT INSTALLATION.
  - 1.4. ONE ORIGINAL SET OF AS-BUILT DRAWINGS MUST BE PROVIDED WITHIN TWO (2) WEEKS AFTER COMPLETION OF CONSTRUCTION FOR THE ICN MANAGEMENT RECORDS. REDLINE AS-BUILT DRAWINGS MUST BE COMPLETE.
2. CONTRACTOR SHALL PROVIDE SPLICING REDLINE OF ALL SPLICING COMPLETED AND VALIDATION THAT THE SPLICE PLAN WAS FOLLOWED.
3. CONTRACTOR IS RESPONSIBLE TO LOCATE FIBER UNTIL ACCEPTANCE BY THE ICN. ACCEPTANCE INCLUDES:
  - 3.1. SUBMISSION OF CONSTRUCTION AND SPLICING RED LINE DRAWINGS BY CONTRACTOR.
  - 3.2. ASSIGNMENT OF LINK NUMBER BY THE ICN (IF APPLICABLE).
  - 3.3. SUBMISSION OF FINAL AS BUILT DRAWING BY THE ICN TO THE ICN NETWORK MAINTENANCE PROVIDER.
  - 3.4. SUBMISSION TO IOWA ONE CALL AND THE ICN NETWORK MAINTENANCE PROVIDER'S CONTRACT LOCATER.
  - 3.5. THE MEASUREMENTS IN THE STATEMENT OF WORK ARE ESTIMATES AND NEED TO BE VERIFIED BY THE CONTRACTOR.
4. ONLY WRITTEN MODIFICATIONS TO THIS SCOPE OF WORK ARE BINDING - VERBAL CHANGES TO THIS SCOPE OF WORK BY ANY PERSON OR PERSONS ARE NOT BINDING, UNLESS CONFIRMED IN WRITING.
5. FINAL PAYMENT WILL NOT BE PROCESSED UNTIL ALL DELIVERABLES ARE RECEIVED AND ACCEPTED.



ICN OSKALOOSA—PSAP CENTER TO EXISTING ICN HANDHOLE

1	90% REVIEW	7/27/2020
2	FINAL PLANS	7/29/2020
3		
4		

**hbk**

**IOWA COMMUNICATIONS NETWORK**  
 400 EAST 14TH STREET  
 GRIMES STATE OFFICE BUILDING  
 DES MOINES, IOWA 50319  
 ICN © 2019, COPY WITH PERMISSION

MATERIALS

ICN Provided Material List (Warehouse Contact Paul Dange 515.725.4749)			
Item	ICN Part Number	Qty	Notes
<b>FIBER CABLE</b>			
12 strand Armored SM fiber	012EUC-T4100D20	5,000	
<b>HANDHOLES AND LIDS</b>			
Bulk 24"x36"x24" with lid Tier 22	BULKU2436240061001	1	
Bulk 24"x36"x36" with lid Tier 22	BULKU2436360061001	4	
Bulk Puck ICN Logo Black	ACC7734-125	5	
<b>LOCATE FACILITIES</b>			
<b>LOCATE STATIONS</b>			
Locate Box (Custom with Isolever)	ISOLOCBOX	1	
<b>GROUNDING</b>			
Erico 1/2" x 6' Ground Rod (Graybar)	611360	1	
Burndy 1/2" Ground Rod Clamp (Anixter)	GRC12	1	
<b>MARKERS FLAGS DECALS</b>			
ICN Snap Around Vulcan 4"x4" 15Mil Coiled Pvc (ICN-4x4-Sa)	1502345 (ICN-4x4-SA)	10	
<b>TERMINATION ITEMS: FDP, BULKHEADS, TRAYS, &amp; RELATED</b>			
Closet Connector Housing (CCH), 1 rack unit, holds 2 CCH cassettes	CCH-01U	1	
CCH Pigtailed Splice Cassette, 12 F, SC UPC Duplex, SM, SF <i>PRE-ASSEMBLED</i>	CCH-CS-12-59-P00RE	1	

LISTING OF CONDUIT & FIBER WORK					
CONDUIT RUN	FROM	TO	LENGTH	2" CONDUIT	12 SM ARMORED FIBER, UNDERGROUND
1	MECH ROOM	HH1	455	455	455
2		HH1	182	182	182
3		HH2	1227	1227	1227
4		HH3	1289	1289	1289
5		HH4	715	0	715
TOTAL					<b>3868</b>

LISTING OF HANDHOLE WORK				
HANDHOLE LABEL	HANDHOLE TYPE	ROUTE	STATION	12 SM ARMORED FIBER COIL
HH1	24" X 36" X 36"	S. 3RD ST	4+55	100
HH2	24" X 36" X 36"	HIGH AVE E	6+37	100
HH3	24" X 36" X 36"	HIGH AVE E	18+64	100
HH4	24" X 36" X 36" 24" X 36" X 24"	B AVE E	31+53	100
EX. HH	EXISTING ICN (75' TAIL SPLICE)	N. 11TH ST	38+68	75
TOTAL				<b>475</b>

ESTIMATE OF QUANTITIES				
ITEM NO.	ITEM	UNIT	PLANNED TOTAL	AS-BUILT TOTAL
1	MOBILIZATION	LS	1	
2	INSTALL 24" X 36" X 36" HANDHOLE	EA	4	
3	INSTALL 24" X 36" X 24" HANDHOLE	EA	1	
3	2" CONDUIT	LF	3153	
4	12 SM ARMORED FIBER (TOTAL)	LF	4343	
5	12 SM ARMORED FIBER (RUNNING LINE)	LF	3868	
6	12 SM ARMORED FIBER (COIL)	LF	475	

NOTE: THIS TABLE SHOWS APPROXIMATE LENGTHS IN CONDUIT ONLY AND DOES NOT INCLUDE ANY COILS OR SLACK FOR FINER CABLES, TRACER WIRE, PULL ROPE, ETC. CONTRACTOR SHALL VERIFY NECESSARY QUANTITIES INCLUDING COILS.

NOTE: CONDUIT INSTALLATION METHOD SHALL BE BORED UNDER ANY ROADWAYS, DRIVEWAYS, AND PAVED SURFACES. THE METHOD BETWEEN PLOW VERSUS BORE FOR CONDUIT INSTALLATION IS AT THE CONTRACTORS DISCRETION.

**NOTE ON HDPE CONDUIT AND SPLICES:**

- HDPE SHALL BE ORANGE SMOOTH WALL SDR 13.5
- DUCT SPLICES SHALL BE MADE OF THE FOLLOWING (IN ORDER OF PREFERENCE.)
  - CRIMP ON
  - CLAMP ON / BOLT ON (SPLIT COUPLINGS)
  - PUSH ON
- ALL SPLICES SHALL BE AIR AND WATER TIGHT
- DUCT SPLICES SHALL BE OF A TYPE MADE SPECIFICALLY FOR JOINING HDPE CONDUIT
- ALL DUCT SPLICES SHALL BE MADE IN SUCH MANNER AS TO ALLOW CONTINUOUS PULLING OF CABLE THROUGH DUCT.

**\*\*ANY EXCEPTIONS MUST BE AGREED UPON IN WRITING PRIOR TO CONSTRUCTION\*\***



ICN OSKALOOSA-PSAP CENTER TO EXISTING ICN HANDHOLE		<b>hbk</b>
1	90% REVIEW	7/27/2020
2	FINAL PLANS	7/29/2020
3		
4		

**IOWA COMMUNICATIONS NETWORK**  
 400 EAST 14TH STREET  
 GRIMES STATE OFFICE BUILDING  
 DES MOINES, IOWA 50319  
 ICN © 2019, COPY WITH PERMISSION

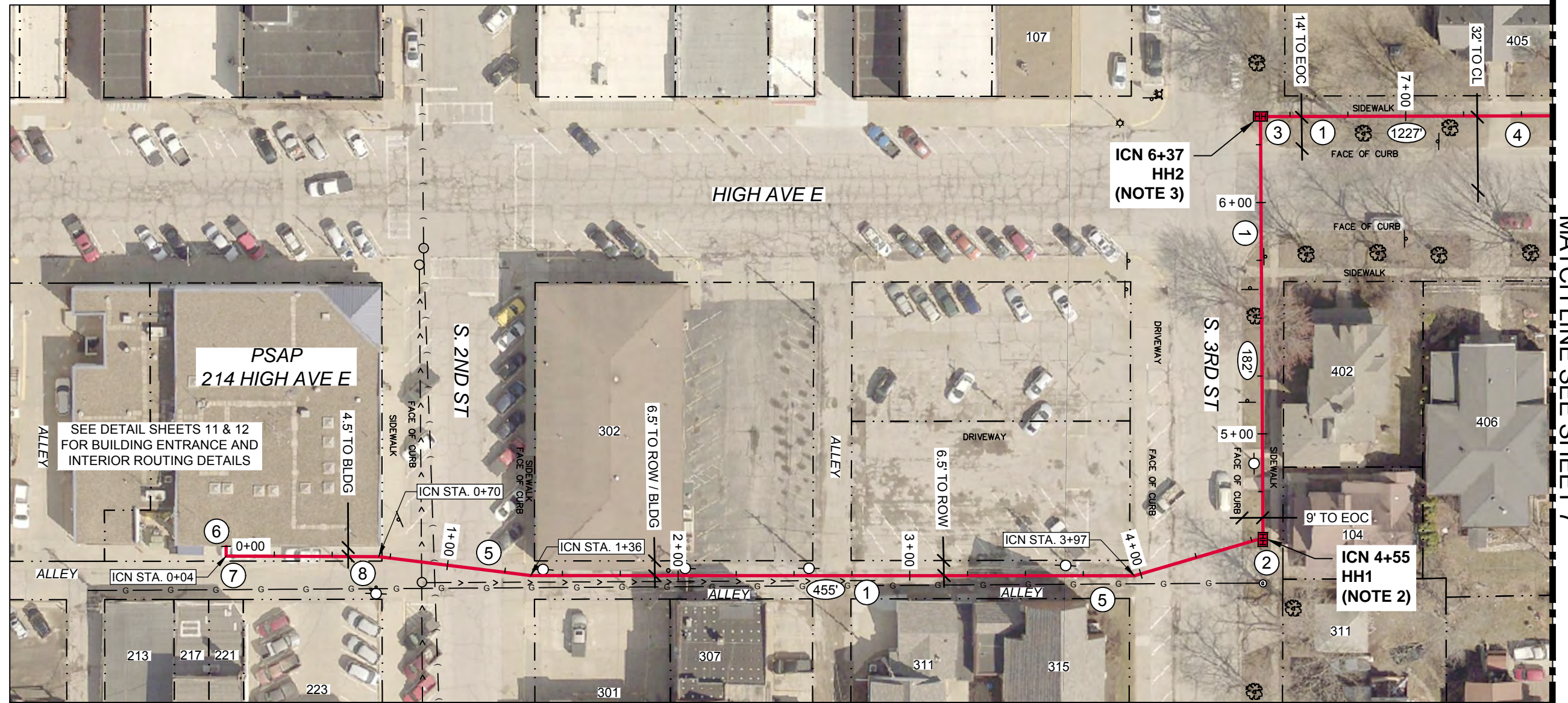

MATCH LINE SEE SHEET 7

- ① PULL NEW LINK 1511B 12 F/A THROUGH NEW 2" HDPE CONDUIT. ARMORED CABLE TO BE USED FOR LOCATING. 42" MINIMUM BELOW GRADE.
- ② ICN STA. 4+55 INSTALL PROPOSED 24"x36"x36" ICN HANDHOLE - HH1. 100' SLACK COIL 12 F/A.
- ③ ICN STA. 6+37 INSTALL PROPOSED 24"x36"x36" ICN HANDHOLE - HH2. 100' SLACK COIL 12 F/A.
- ④ BORE CONDUIT/FIBER LINE APPROXIMATELY 1'-0" OFF SOUTH EDGE OF SIDEWALK FROM ICN STA. 6+37 TO ICN STA. 25+02.
- ⑤ CAUTION IN THIS AREA. MULTIPLE UTILITIES PRESENT.
- ⑥ ICN STA. 0+00. PULL NEW LINK 1511B 12 F/A THROUGH NEW CONDUIT TO FIBER LB OUTSIDE BUILDING BELOW BRICK SILL ON WALL. SEE SHEET 14 FOR MOUNTING DETAILS. FOR INTERIOR ROUTE DETAILS, SEE SHEET 12.

- ⑦ REMOVE AND REPLACE CONCRETE. CONCRETE REPLACEMENT SHALL BE COORDINATED WITH THE COUNTY AND SHALL MATCH EXISTING CONCRETE PAVEMENT AND CURBING. CONTRACTOR SHALL COORDINATE WITH MAZZITELLO PROFESSIONAL SERVICES FOR PROPOSED TOWER LOCATION AND TIMELINE ON CONSTRUCTION. SEE DETAIL SHEETS 11 & 12 FOR EXTERIOR AND INTERIOR DETAILS. SEE DETAIL SHEET 13 FOR PROPOSED TOWER PLANS.
- ⑧ AVOID UPN FIBER. APPROXIMATE LOCATION.

MAHASKA COUNTY  
LINCOLN TOWNSHIP  
T75-N R-16W

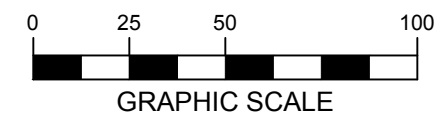

LISTING OF HANDHOLES				
HANDHOLE	STATION	HANDHOLE	STATION	LENGTH FT
MECH ROOM	0+00	HH1	4+55	455
HH1	4+55	HH2	6+37	182
HH2	6+37	HH3	18+64	1227
TOTAL				1864

\* LENGTH DOES NOT INCLUDE SLACKCOILS



ICN OSKALOOSA-PSAP CENTER TO EXISTING ICN HANDHOLE

1	90% REVIEW	7/27/2020
2	FINAL PLANS	7/29/2020
3		
4		

**hbk icn**

**IOWA COMMUNICATIONS NETWORK**  
400 EAST 14TH STREET  
GRIMES STATE OFFICE BUILDING  
DES MOINES, IOWA 50319  
ICN © 2019, COPY WITH PERMISSION

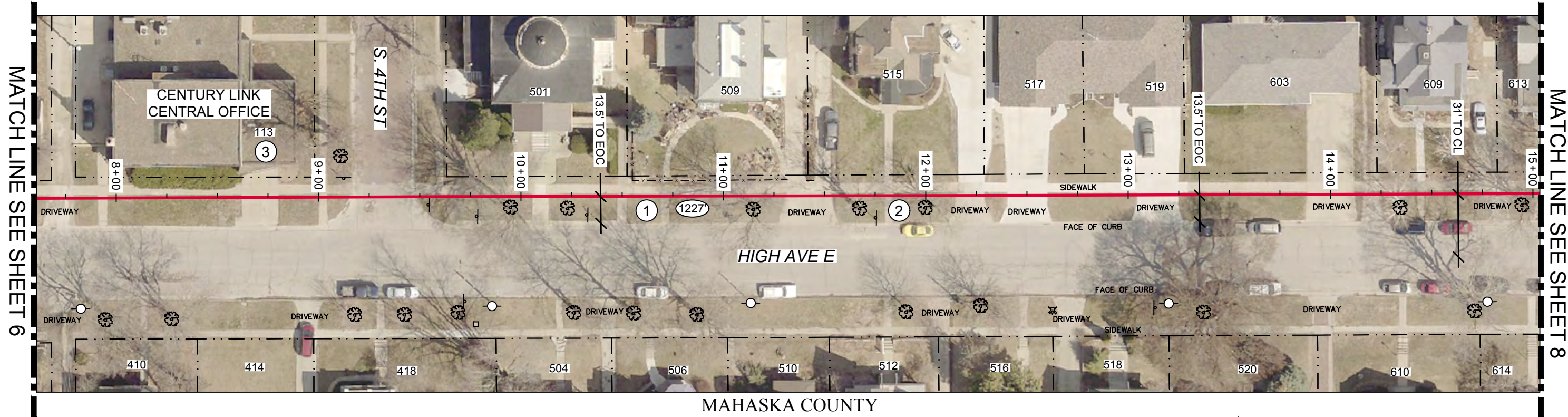

MAHASKA COUNTY  
LINCOLN TOWNSHIP  
T75-N R-15W

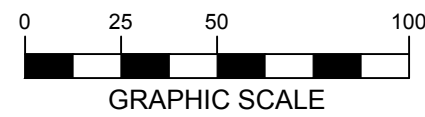

- ① PULL NEW LINK 1511B 12 F/A THROUGH NEW 2" HDPE CONDUIT. ARMORED CABLE TO BE USED FOR LOCATING. 42" MINIMUM BELOW GRADE.
- ② BORE CONDUIT/FIBER LINE APPROXIMATELY 1'-0" OFF SOUTH EDGE OF SIDEWALK FROM ICN STA. 6+37 TO ICN STA. 25+02.
- ③ NOTE: CENTRAL OFFICE FOR CENTURY LINK. 113 S. 4TH STREET. EXISTING FIBER LOCATIONS UNKNOWN - TAKE CAUTION.
- ④ OTHER UTILITY PROVIDERS IN AREA. STAY 36" CLEAR FROM ALL EXISTING UTILITIES.

LISTING OF HANDHOLES				
HANDHOLE	STATION	HANDHOLE	STATION	LENGTH FT
HH2	6+37	HH3	18+64	1227
TOTAL				1227

\* LENGTH DOES NOT INCLUDE SLACKCOILS



ICN OSKALOOSA-PSAP CENTER TO EXISTING ICN HANDHOLE

1	90% REVIEW	7/27/2020
2	FINAL PLANS	7/29/2020
3		
4		

**hbk** **ICN**

**IOWA COMMUNICATIONS NETWORK**  
400 EAST 14TH STREET  
GRIMES STATE OFFICE BUILDING  
DES MOINES, IOWA 50319  
ICN © 2019, COPY WITH PERMISSION

MATCH LINE SEE SHEET 7

MATCH LINE SEE SHEET 9



MAHASKA COUNTY  
LINCOLN TOWNSHIP  
T75-N R-15W

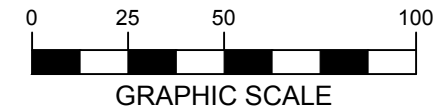
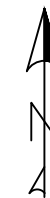

- ① PULL NEW LINK 1511B 12 F/A THROUGH NEW 2" HDPE CONDUIT. ARMORED CABLE TO BE USED FOR LOCATING. 42" MINIMUM BELOW GRADE.
- ② ICN STA. 18+64 INSTALL PROPOSED 24"x36"x36" ICN HANDHOLE - HH3. 100' SLACK COIL 12 F/A. GAS PAINT FOUND IN AREA - USE CAUTION.
- ③ BORE CONDUIT/FIBER LINE APPROXIMATELY 1'-0" OFF SOUTH EDGE OF SIDEWALK FROM ICN STA. 6+37 TO ICN STA. 25+02.
- ④ OTHER UTILITY PROVIDERS IN AREA. STAY 36" CLEAR FROM ALL EXISTING UTILITIES.

NORTH SIDE OF HIGH AVE E.  
LOOKING WEST AT S. 7TH ST



HH3 - ICN STA. 18+64

LISTING OF HANDHOLES				
HANDHOLE	STATION	HANDHOLE	STATION	LENGTH FT
HH2	6+37	HH3	18+64	1227
HH3	18+64	HH4	31+53	1289
TOTAL				2516

\* LENGTH DOES NOT INCLUDE SLACKCOILS



ICN OSKALOOSA-PSAP CENTER TO EXISTING ICN HANDHOLE



1	90% REVIEW	7/27/2020
2	FINAL PLANS	7/29/2020
3		
4		

**IOWA COMMUNICATIONS NETWORK**  
400 EAST 14TH STREET  
GRIMES STATE OFFICE BUILDING  
DES MOINES, IOWA 50319  
ICN © 2019, COPY WITH PERMISSION

MATCH LINE SEE SHEET 10

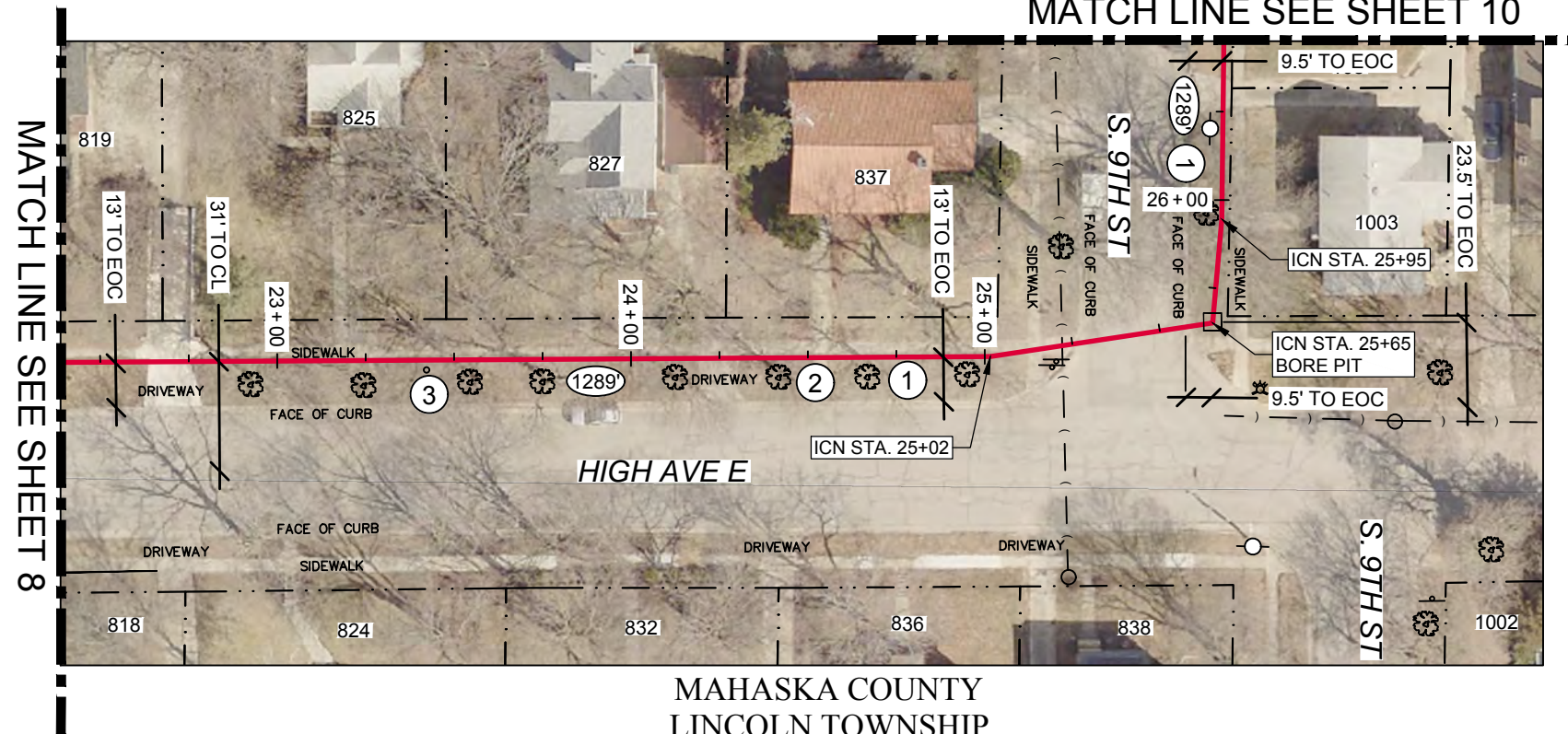

MAHASKA COUNTY  
LINCOLN TOWNSHIP  
T75-N R-15W

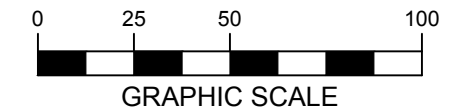
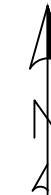

- ① PULL NEW LINK 1511B 12 F/A THROUGH NEW 2" HDPE CONDUIT. ARMORED CABLE TO BE USED FOR LOCATING. 42" MINIMUM BELOW GRADE.
- ② BORE CONDUIT/FIBER LINE APPROXIMATELY 1'-0" OFF SOUTH EDGE OF SIDEWALK FROM ICN STA. 6+37 TO ICN STA. 25+02.
- ③ AVOID RECENTLY INSTALLED WATER SHUT OFF.
- ④ OTHER UTILITY PROVIDERS IN AREA. STAY 36" CLEAR FROM ALL EXISTING UTILITIES.

NORTH SIDE OF HIGH AVE E  
AT ADDRESS NO. 825



EAST SIDE OF S. 9TH ST  
LOOKING WEST ON HIGH AVE E



BORE PIT LOCATION  
ICN STA. 25+65

LISTING OF HANDHOLES				
HANDHOLE	STATION	HANDHOLE	STATION	LENGTH FT
HH3	18+64	HH4	31+53	1289
TOTAL				<b>1289</b>

\* LENGTH DOES NOT INCLUDE SLACKCOILS



ICN OSKALOOSA-PSAP CENTER TO  
EXISTING ICN HANDHOLE

1	90% REVIEW	7/27/2020
2	FINAL PLANS	7/29/2020
3		
4		

**hbk** **ICN**

**IOWA COMMUNICATIONS NETWORK**  
400 EAST 14TH STREET  
GRIMES STATE OFFICE BUILDING  
DES MOINES, IOWA 50319  
ICN © 2019, COPY WITH PERMISSION

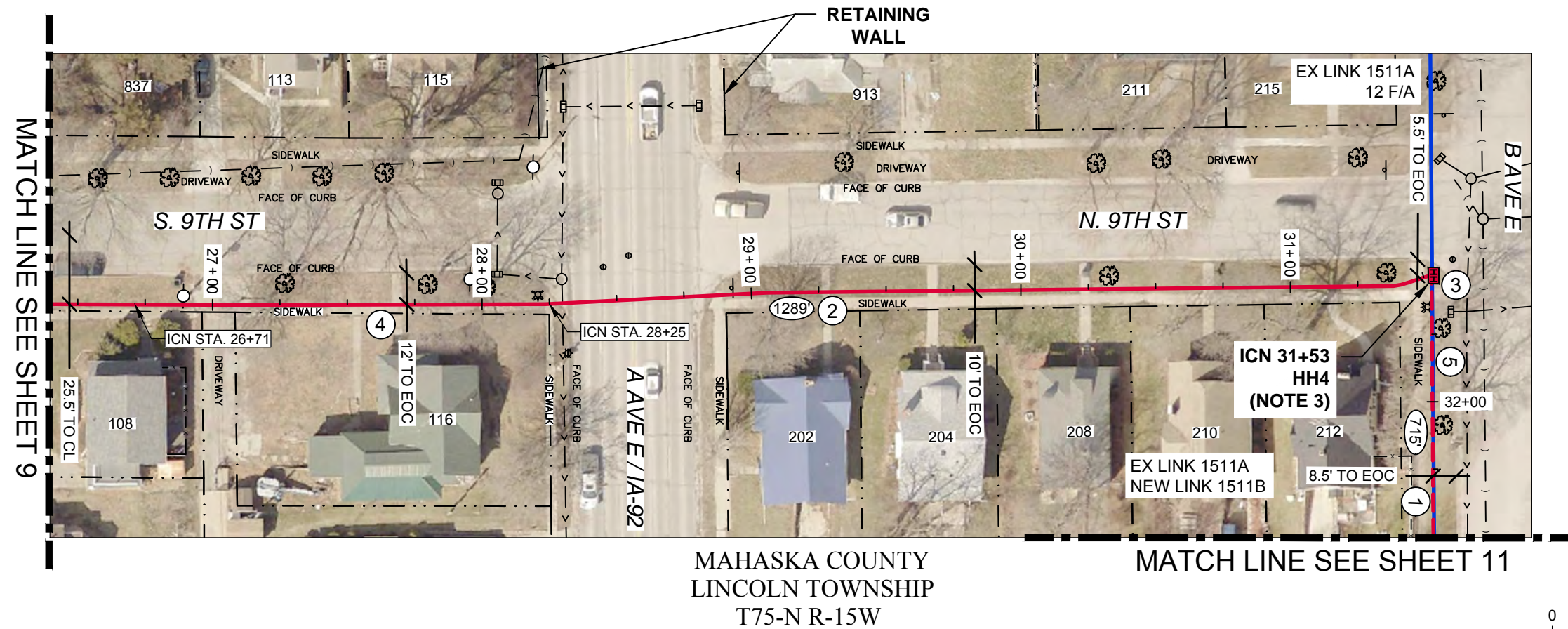

MAHASKA COUNTY  
LINCOLN TOWNSHIP  
T75-N R-15W

MATCH LINE SEE SHEET 11

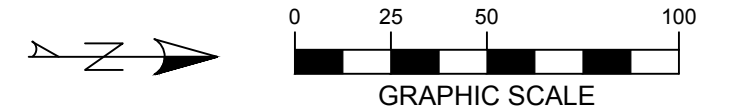

- ① PULL NEW LINK 1511B 12 F/A THROUGH EXISTING 1-1/4" HDPE CONDUIT NEXT TO EXISTING LINK 1511A FROM ICN STA. 31+53 TO ICN STA. 38+68. EXISTING LINK 1511A SHALL NOT BE DAMAGED. ARMORED CABLE TO BE USED FOR LOCATING.
- ② PULL NEW LINK 1511B 12 F/A THROUGH NEW 2" HDPE CONDUIT. 42" MINIMUM BELOW GRADE.
- ③ ICN STA. 31+53 INSTALL PROPOSED 24"x36"x36" & 24"x36"x24" ICN HANDHOLES **STACKED VERTICALLY** - HH4. 100' SLACK COIL 12 F/A. THE DEPTH AT THIS LOCATION FOR THE EXISTING ICN DUCT IS 5'-0". INSTALL SPLIT CONDUIT WYE OVER EXISTING CONDUIT AFTER CUTTING WINDOW INTO CONDUIT. SEE SPECIFICATION SHEET 15 FOR DETAILS. **CAUTION: ACTIVE ICN BACKBONE.**
- ④ THE CITY OF OSKALOOSA APPROVED BORING UNDER THE SIDEWALK FROM ICN STA. 26+71 TO ICN STA. 28+25 TO AVOID EXISTING UTILITIES AND TREES IN THE ROW. REPAIR SIDEWALK TO MATCH EXISTING AS NECESSARY.
- ⑤ CAUTION IN THIS AREA. MULTIPLE UTILITIES PRESENT.

SE CORNER OF B AVE E & N. 9TH ST



HH4 - ICN STA. 31+53

SE CORNER OF B AVE E & N. 9TH ST

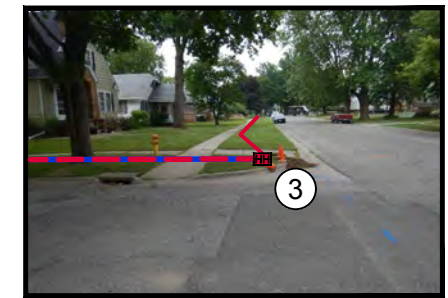

HH4 - ICN STA. 31+53

EAST SIDE S. 9TH ST



ICN STA. 26+71 - 28+25

LISTING OF HANDHOLES				
HANDHOLE	STATION	HANDHOLE	STATION	LENGTH FT
HH3	18+64	HH4	31+53	1289
HH4	31+53	EX ICN HH	38+68	715
TOTAL				2004

\* LENGTH DOES NOT INCLUDE SLACKCOILS



ICN OSKALOOSA-PSAP CENTER TO EXISTING ICN HANDHOLE

1	90% REVIEW	7/27/2020
2	FINAL PLANS	7/29/2020
3		
4		

**hbk** **ICN**

**IOWA COMMUNICATIONS NETWORK**  
400 EAST 14TH STREET  
GRIMES STATE OFFICE BUILDING  
DES MOINES, IOWA 50319  
ICN © 2019, COPY WITH PERMISSION

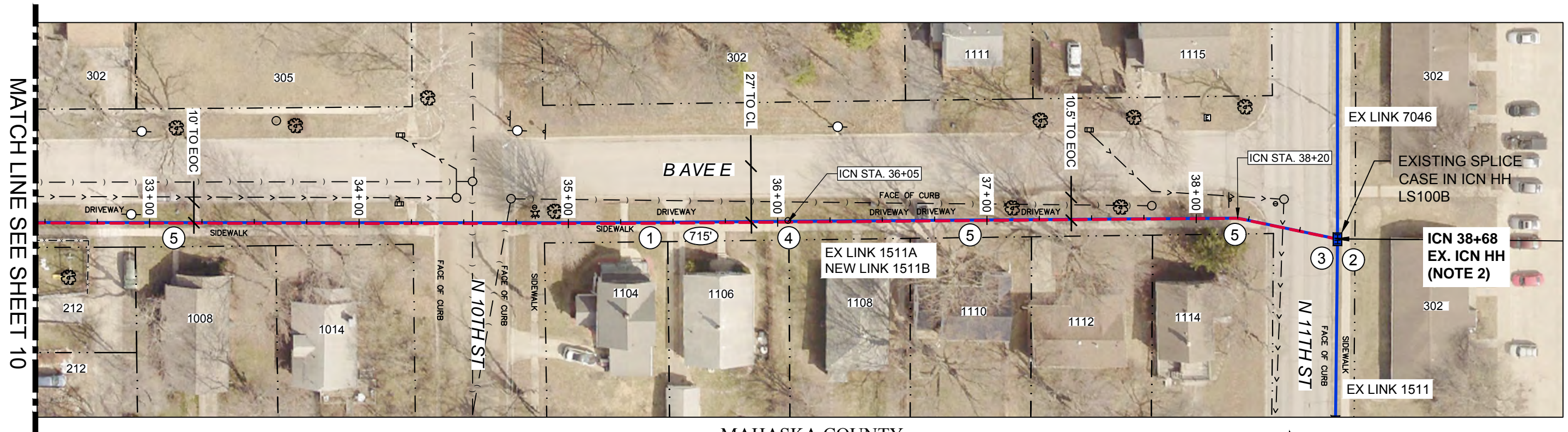

MAHASKA COUNTY  
LINCOLN TOWNSHIP  
T75-N R-15W

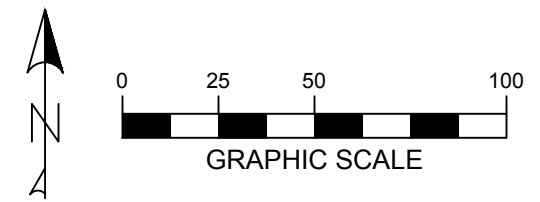

- ① PULL NEW LINK 1511B 12 F/A THROUGH EXISTING 1-1/4" HDPE CONDUIT NEXT TO EXISTING LINK 1511A FROM ICN STA. 31+53 TO ICN STA. 38+68. EXISTING LINK 1511A SHALL NOT BE DAMAGED. ARMORED CABLE TO BE USED FOR LOCATING.
- ② ICN STA. 38+68 - EXISTING ICN HANDHOLE. SPLICE INTO EXISTING SPLICE CASE - LS100B. ADD NEW LINK 1511B 12 F/A INTO CASE. SPLICING BY OTHERS. INSTALL NEW TRACER WIRE AND TEMPORARILY BOND TO NEW 12 F/A. 75' TAIL SLACK COIL 12 F/A.
- ③ INSTALL NEW #12 TRACER WIRE FROM AN OPEN TERMINAL ON THE EXISTING TRIVIEW LOCATE PEDESTAL TO THE EXISTING HANDHOLE. TEMPORARILY BOND TRACER WIRE TO THE END OF THE NEW ARMORED CABLE. LEAVE 25' OF #12 TRACER WIRE IN HANDHOLE FOR SPLICER TO COMPLETE THE PERMANENT BOND.
- ④ ICN STA. 36+05 - ASSIST PIT LOCATION TO ACCESS EXISTING DUCT - LOCATED BETWEEN 1106 & 1108 B AVE E - APPROXIMATELY 3'-0" DEEP. IF CONDUIT HAS TO BE ACCESSED TO PULL IN SECOND CABLE; REPAIR WITH SPLIT CONDUIT. NOTE: THE EXISTING GAS MAIN AND ICN FIBER DUCT ARE APPROXIMATELY 2" APART.
- ⑤ CAUTION IN THIS AREA. MULTIPLE UTILITIES PRESENT.

B/T 1106 & 1108 B AVE E

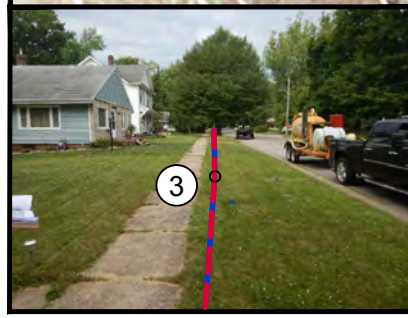
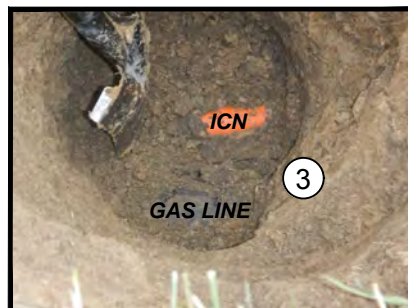

ASSIST PIT LOCATION  
ICN STA. 36+05

NE CORNER OF B AVE E & N. 11TH ST



EXISTING ICN HH &  
SPLICE CASE - LS100B  
ICN STA. 38+68

LISTING OF HANDHOLES				
HANDHOLE	STATION	HANDHOLE	STATION	LENGTH FT
HH4	31+53	EX ICN HH	38+68	715
TOTAL				715

\* LENGTH DOES NOT INCLUDE SLACKCOILS



ICN OSKALOOSA-PSAP CENTER TO EXISTING ICN HANDHOLE

1	90% REVIEW	7/27/2020
2	FINAL PLANS	7/29/2020
3		
4		

**hbk icn**  
IOWA COMMUNICATIONS NETWORK  
400 EAST 14TH STREET  
GRIMES STATE OFFICE BUILDING  
DES MOINES, IOWA 50319  
ICN © 2019, COPY WITH PERMISSION

SEE PAGES 5 AND 12 FOR BUILDING ENTRANCE AND INTERIOR ROUTING DETAILS

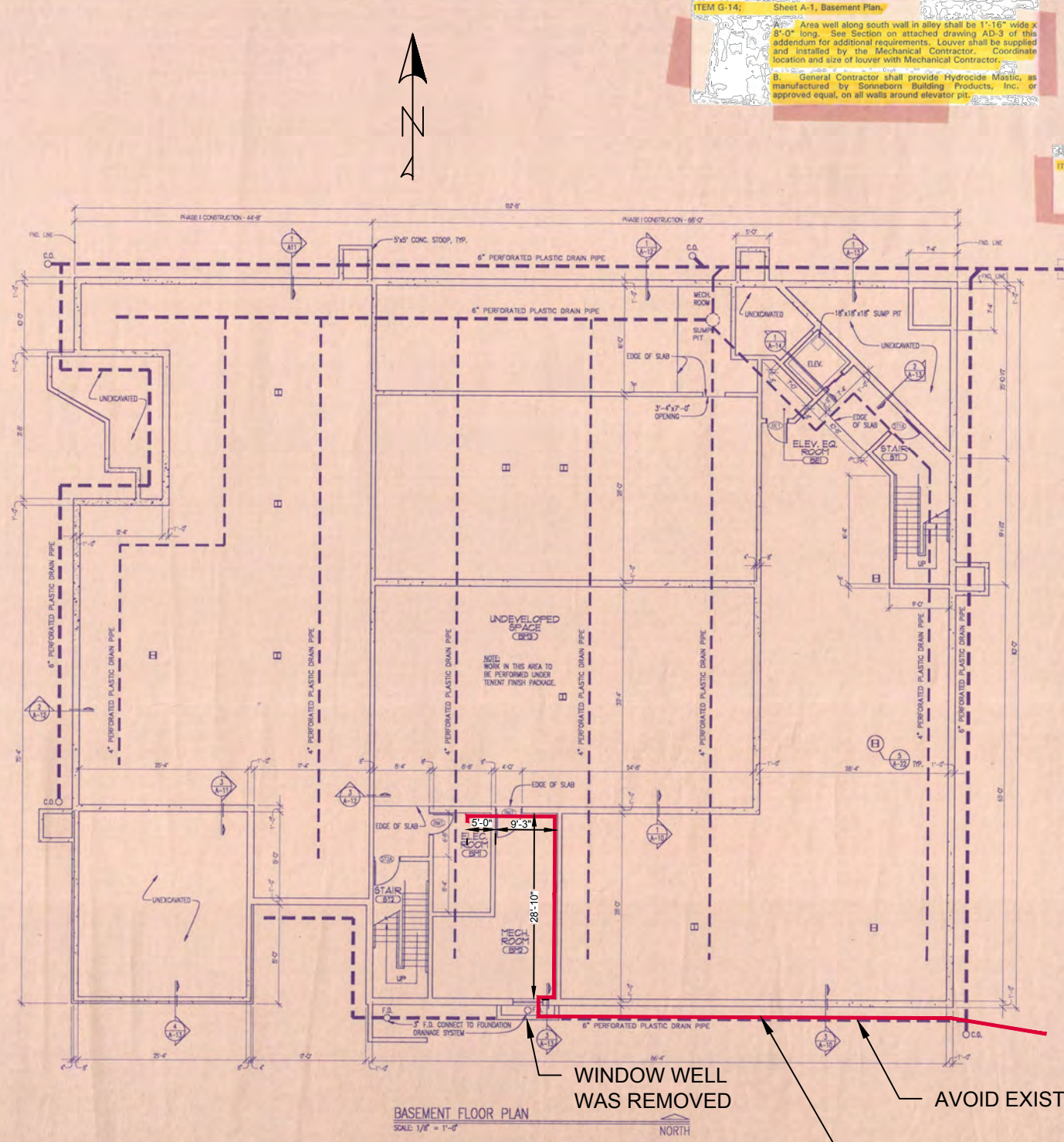

**ITEM G-14:** Sheet A-1, Basement Plan.  
 A. Area well along south wall in alley shall be 1'-16" wide x 8'-0" long. See Section on attached drawing AD-3 of this addendum for additional requirements. Louver shall be supplied and installed by the Mechanical Contractor. Coordinate location and size of louver with Mechanical Contractor.  
 B. General Contractor shall provide Hydrocide Mastic, as manufactured by Sotaborn Building Products, Inc. or approved equal, on all walls around elevator pit.

**ITEM G-7:** Sheet A-1, Basement Plan.  
 A. The foundation drainage piping as shown on Sheet A-1 shall be installed so it discharges into the sump pit. The mechanical contractor shall provide and install the sump pit and all piping from the pit to the existing storm sewer inlet.

- BASEMENT FLOOR PLAN NOTES:**
1. SEE STRUCTURAL DRAWINGS FOR FOOTINGS AND ADDITIONAL REQUIREMENTS.
  2. ALL WALLS, FLOORS, CEILINGS, ETC. WITHIN THE UNFINISHED AREAS SHALL REQUIRE NO WORK AT THIS TIME. ALL FINISHES SHALL BE PROVIDED, ONCE THE OWNER DECIDES TO PROCEED WITH FINISHING OFF THESE AREAS. SEE ROOM FINISH SCHEDULE ON SHEET A-8 FOR ADDITIONAL INFORMATION AND REQUIREMENTS.
  3. PROVIDE AND INSTALL UNDER SLAB AND FOUNDATION DRAINAGE SYSTEM AS SHOWN AND SPECIFIED IN SECTION 02550. CONNECT SYSTEM TO EXISTING STORM SEWER INLET. CONTRACTOR SHALL VERIFY LOCATION AND FLOW LINE ELEV. OF EXIST. STRUCTURES.
  4. GENERAL CONTRACTOR SHALL BLOCKOUT, FORM AND POUR AN 18"x18"x18" SUMP PIT IN THE ELEVATOR SHAFT AS SHOWN ON DRAWINGS. COORDINATE ADDITIONAL REQUIREMENTS WITH MECHANICAL CONTRACTOR.
  5. GENERAL CONTRACTOR SHALL COORDINATE AND INSTALL ALL SUB-SOIL DRAINAGE SYSTEM AND FOUNDATION DRAINAGE SYSTEM AS SHOWN ON DRAWINGS. GENERAL CONTRACTOR SHALL DIG THE HOLE FOR THE CAST IRON BISEN AS SUPPLIED AND INSTALLED BY MECHANICAL CONTRACTOR, AND SHALL BACKFILL AROUND BISEN ONCE IT IS INSTALLED. GENERAL CONTRACTOR SHALL MAKE CONNECTIONS TO THE BISEN AND TO THE CAST IRON DISCHARGE FROM THE SUMP PIT AT THE EXTERIOR SIDE OF THE WALL WITH THE FOUNDATION DRAINAGE SYSTEM.
  6. GENERAL CONTRACTOR SHALL COORDINATE THE INSTALLATION OF THE SUB-SOIL DRAINAGE SYSTEM AND THE FOUNDATION DRAINAGE SYSTEM WITH THE MECHANICAL CONTRACTOR. USE EXTREME CARE AND ADJUST ELEVATION OF PIPING AS REQUIRED TO AVOID ALL CONFLICT WITH SANITARY SEWER LINES.
  7. ALL GRANULAR FILL FOR THE PROJECT SHALL BE PROVIDED TO THE JOB SITE BY THE COUNTY. GENERAL CONTRACTOR SHALL PLACE, LEVEL AND COMPACT ALL FILL AS REQUIRED IN SECTION 02220 OF THE SPECIFICATIONS. GENERAL CONTRACTOR SHALL NOTIFY THE COUNTY DEPT. OF ROADS 48 HRS. PRIOR TO INCORPORATING THE GRANULAR FILL INTO THE PROJECT AND SHALL INFORM THE COUNTY AS TO THE TYPE AND QUANTITY OF GRANULAR FILL NEEDED.

MOORE & ASSOCIATES, P.C.  
 7007 AMBER AVE.  
 CHAMPAIGN, ILLINOIS 62624  
 PHONE: (618)397-7388



DATE	January 2, 1996
	February 12, 1998

MAHASKA COUNTY  
 CORRECTIONAL CENTER  
 OSKALOOSA, IOWA

BASEMENT FLOOR PLAN

A-1

PSAP - BASEMENT LEVEL FLOORPLAN  
 FLOORPLAN PROVIDED BY MAHASKA COUNTY



ICN OSKALOOSA-PSAP CENTER TO EXISTING ICN HANDHOLE

1	90% REVIEW	7/27/2020
2	FINAL PLANS	7/29/2020
3		
4		

**IOWA COMMUNICATIONS NETWORK**  
 400 EAST 14TH STREET  
 GRIMES STATE OFFICE BUILDING  
 DES MOINES, IOWA 50319  
 ICN © 2019, COPY WITH PERMISSION



PSAP (LAW ENFORCEMENT BUILDING) EXTERIOR AND INTERIOR ROUTE DETAILS

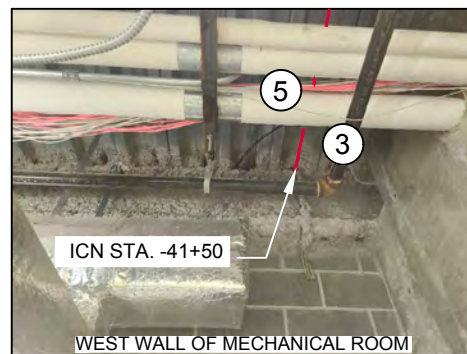
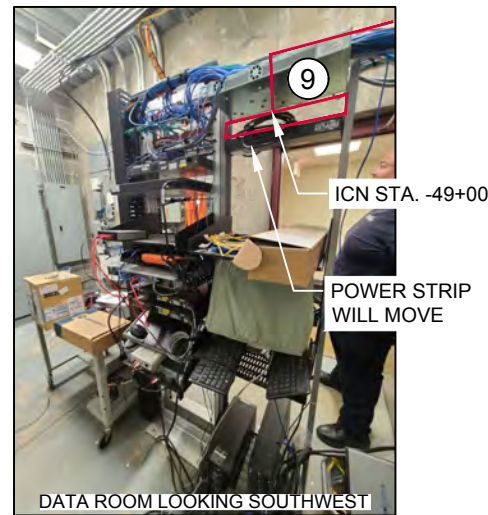
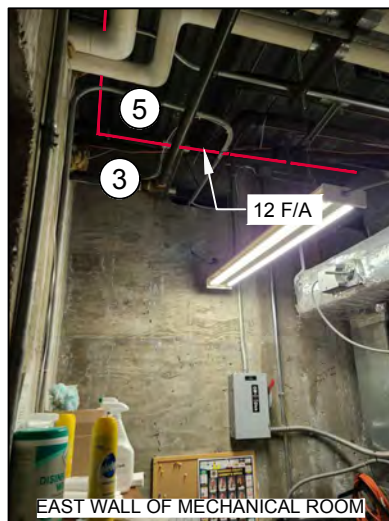
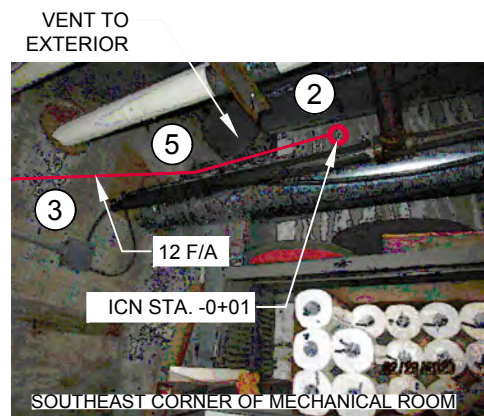
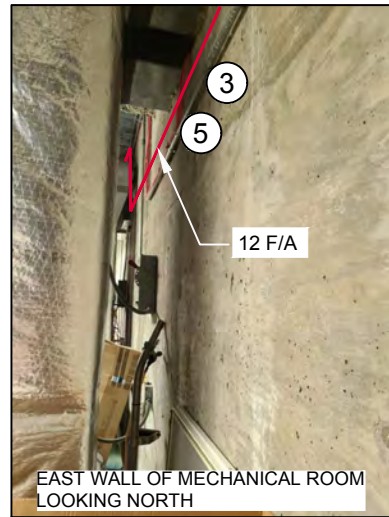
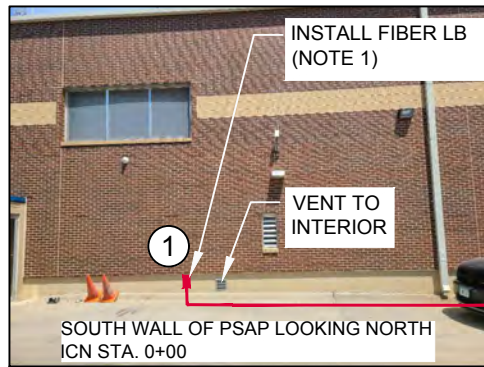

- ① BORE UNDERNEATH THE CONCRETE ALLEY 3'-0" OFF BUILDING WALL. CONDUIT WILL GO UP BUILDING TO FIBER LB. INSTALL ISOLOCBOX AND GROUND ROD WEST OF FIBER LB. SEE DETAIL ON SHEET 14. INSTALL FIBER LB UNDER BRICK WALL SILL ON CONCRETE WALL. CORE THROUGH SOUTH CONCRETE WALL INTO MECHANICAL ROOM. CONTRACTOR SHALL REMOVE AND REPLACE CONCRETE AND CURB TO ITS EXISTING CONDITION AND MATCH EXISTING CURB STRUCTURE. COORDINATE WITH MAZZITELLO PROFESSIONAL SERVICES FOR PROPOSED TOWER INSTALLATION IN THIS LOCATION. MIKE MAZZITELLO: 715-222-4440 / MMAZZITELLOS@GMAIL.COM.
- ② PULL NEW 12 F/A FIBER FROM EXTERIOR WALL PENETRATION. CONTRACTOR TO SEAL ALL PENETRATIONS AND PLUG BUILDING ENTRY CONDUIT UPON COMPLETION OF CABLE INSTALLATION.
- ③ INSTALL 12 F/A IN CORRUGATED 1-1/4" SPLIT DUCT BETWEEN THE BUILDING ENTRANCE AND DATA ROOM. LEAVE 5' OF SLACK FOR SPLICER TO CONNECT PERMANENT BOND.
- ④ INSTALL #12 TRACER WIRE WITH THE 12 F/A INSIDE SPLIT DUCT. WIRE WILL BE USED TO EXTEND THE FIBER CABLE METALLIC ARMOR BACK TO THE BUILDING ENTRANCE. TEMPORARILY BOND THE #12 WIRE TO THE ARMOR AT END OF CABLE. ROUTE TO ISOLOCBOX AND CONNECT - SEE SHEET 12 FOR DETAILS.
- ⑤ FASTEN CORRUGATED 1-1/4" SPLIT DUCT CARRYING THE 12 F/A FIBER AND #12 TRACER WIRE DIRECTLY TO WALL OR CEILING. USE J-HOOKS TO ATTACH TO WALL AND CONDUIT HANGERS TO ATTACH TO CEILING. ENSURE J-HOOKS/HANGERS ARE NOT MORE THAN 3- FEET APART TO REDUCE SAG. DO NOT ATTACH FIBER TO PIPES OR CONDUITS.
- ⑥ ROUTE FIBER FROM BUILDING ENTRANCE TO RACK IN DATA ROOM AS SHOWN IN PICTURES. IN DATA ROOM, SUPPORT FIBER ON EXISTING BRACKETS WHERE POSSIBLE.
- ⑦ LEAVE 25' SLACK COIL ON WALL AND SECURE WITH WALL MOUNT BRACKETS.
- ⑧ AT THE END OF THE PROJECT, LEAVE A PULL ROPE IN ALL CONDUITS AND PATHWAYS BOTH NEW AND EXISTING.
- ⑨ PROPOSED FDP AND EQUIPMENT LOCATION. TWO RACK UNITS REQUIRED (INSTALLED BY OTHERS). VERIFY LOCATION WITH COUNTY E911 ADMINISTRATOR.



ICN OSKALOOSA-PSAP CENTER TO EXISTING ICN HANDHOLE

1	90% REVIEW	7/27/2020
2	FINAL PLANS	7/29/2020
3		
4		

**hbk** **ICN**

**IOWA COMMUNICATIONS NETWORK**  
 400 EAST 14TH STREET  
 GRIMES STATE OFFICE BUILDING  
 DES MOINES, IOWA 50319  
 ICN © 2019, COPY WITH PERMISSION

**PROPOSED TOWER DETAILS**  
INSTALLED BY OTHERS - NOT IN CONTRACT

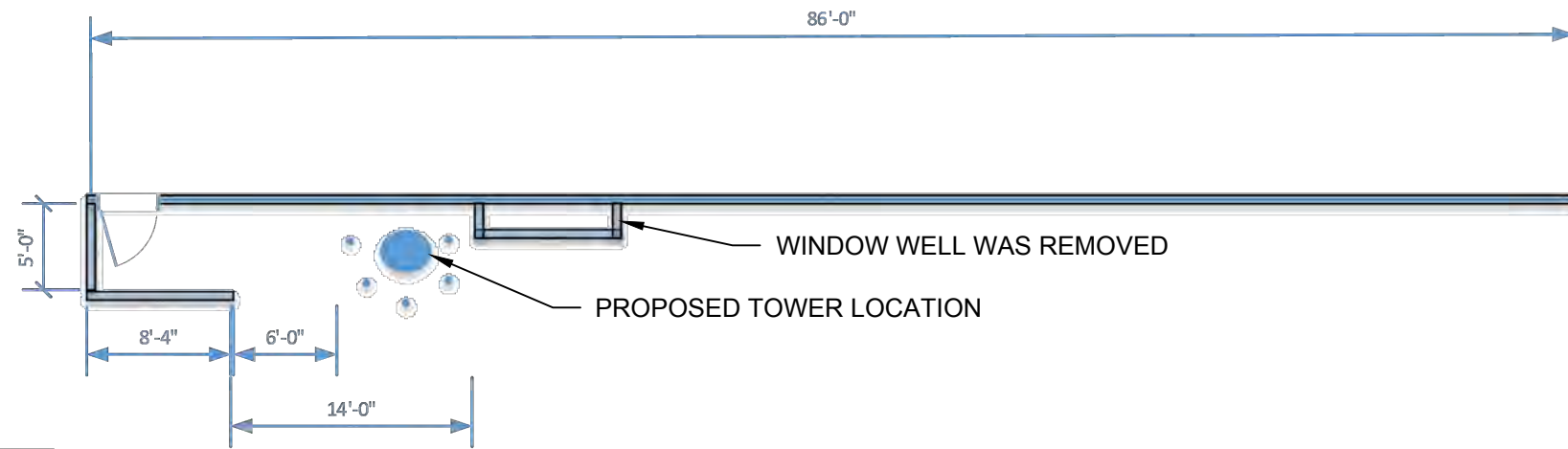

New Self Support Tower (80 feet)

**PSAP Building Entrance and Concrete R & R**

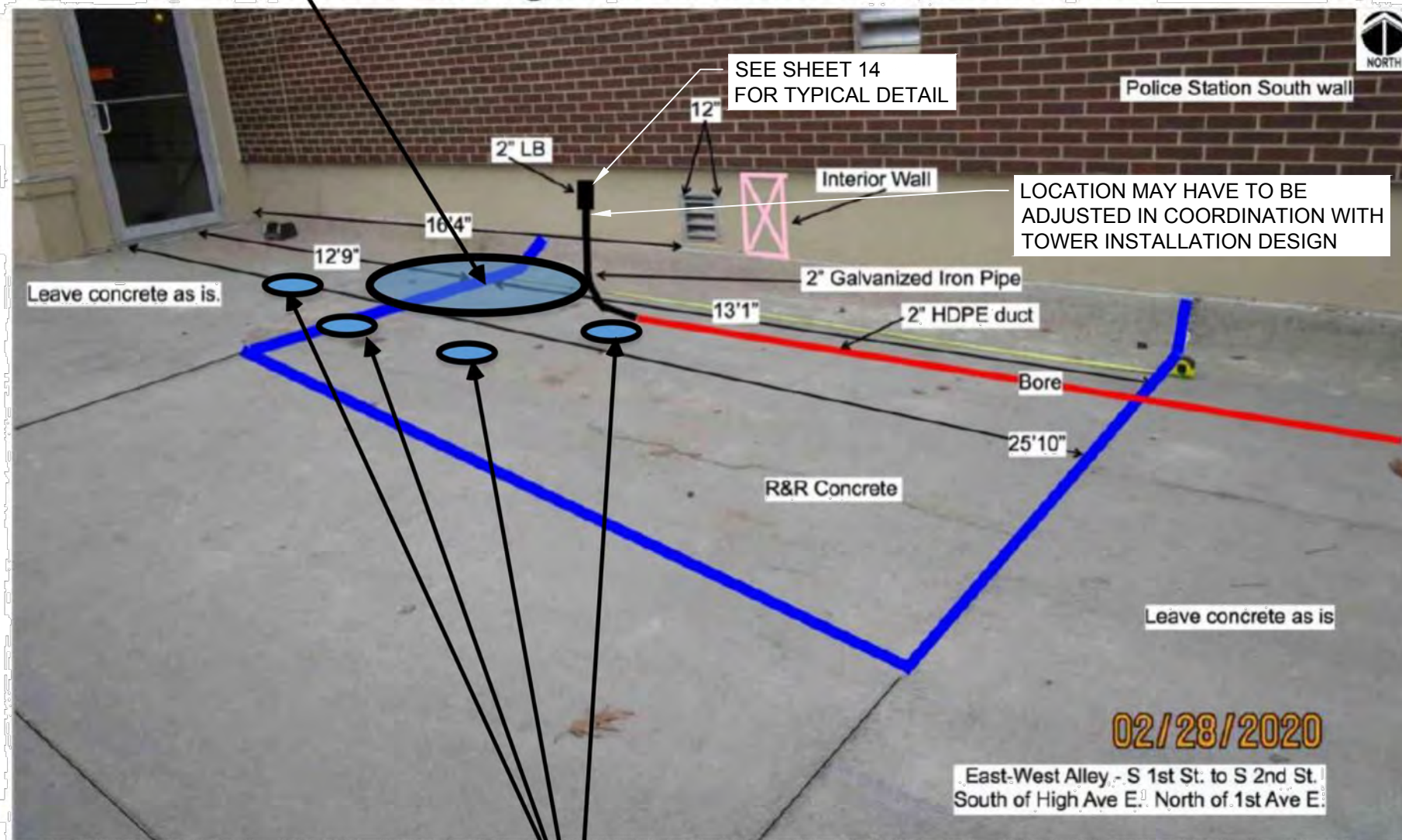

Bollards Protection

Tower Profile	
Load Location	Top
Maximum Height	85' Freestanding / 125' Bracketed
Minimum Height	10' Freestanding / 20' Bracketed
Standard 10' Section Weight (lbs.) (Galv.)	199.23 (1.25' leg) / 253.68 (1.50' leg)
Maximum # of Lines on a Face	2- 7/8" Lines per Face (6 - total)
Leg Size	1.25" and 1.50"
Leg Type	Solid Round
Leg Connection	Three Hole Bolted Flange
Bracing Size	1/2"
Bracing Type	Solid Serpentine
Brace Connection	Welded
Engineering	Pre-Engineered
Climbing Application	Incorporated into Tower Face
Type of Line Support	N/A - Attach directly to bracing members
Sector Mount Compatible	No
Platform Compatible	No
Maximum Sidearm Length	6' Max

Notes:

- EPA is the actual area "seen by the wind" of an appurtenance (antenna, mount, etc.) multiplied by a force coefficient. It is not necessarily the value published by the appurtenance manufacturer. Please refer to [www.tessco.com/go/towers](http://www.tessco.com/go/towers) for a further explanation of and some guidelines on how to calculate EPA.
- ANSI/TIA/EIA-222-F-1996 recommends that designs be evaluated by a registered professional engineer for each specific application.
- For taller or more heavily loaded guyed towers, please see the Sabre 1800 TLWD series.
- Custom engineering of the 1200 TLWD series guyed tower is available for non-catalog loading requirements.



ICN OSKALOOSA-PSAP CENTER TO EXISTING ICN HANDHOLE

1	90% REVIEW	7/27/2020
2	FINAL PLANS	7/29/2020
3		
4		

**hbk** **ICN**

**IOWA COMMUNICATIONS NETWORK**  
400 EAST 14TH STREET  
GRIMES STATE OFFICE BUILDING  
DES MOINES, IOWA 50319  
ICN © 2019, COPY WITH PERMISSION

# TYPICAL ABOVE GROUND BUILDING ENTRANCE WITH LOCATE TERMINAL

ALTERNATIVE TO PULL BOX:  
SMART PATHWAYS LB  
(NOT TO SCALE)

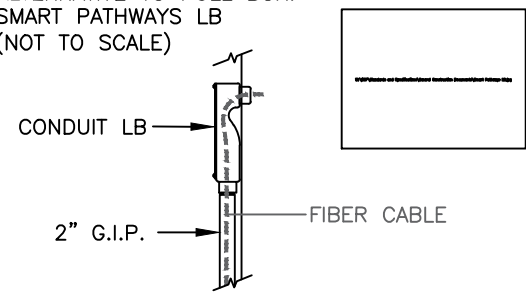

PROFILE

ELEVATION

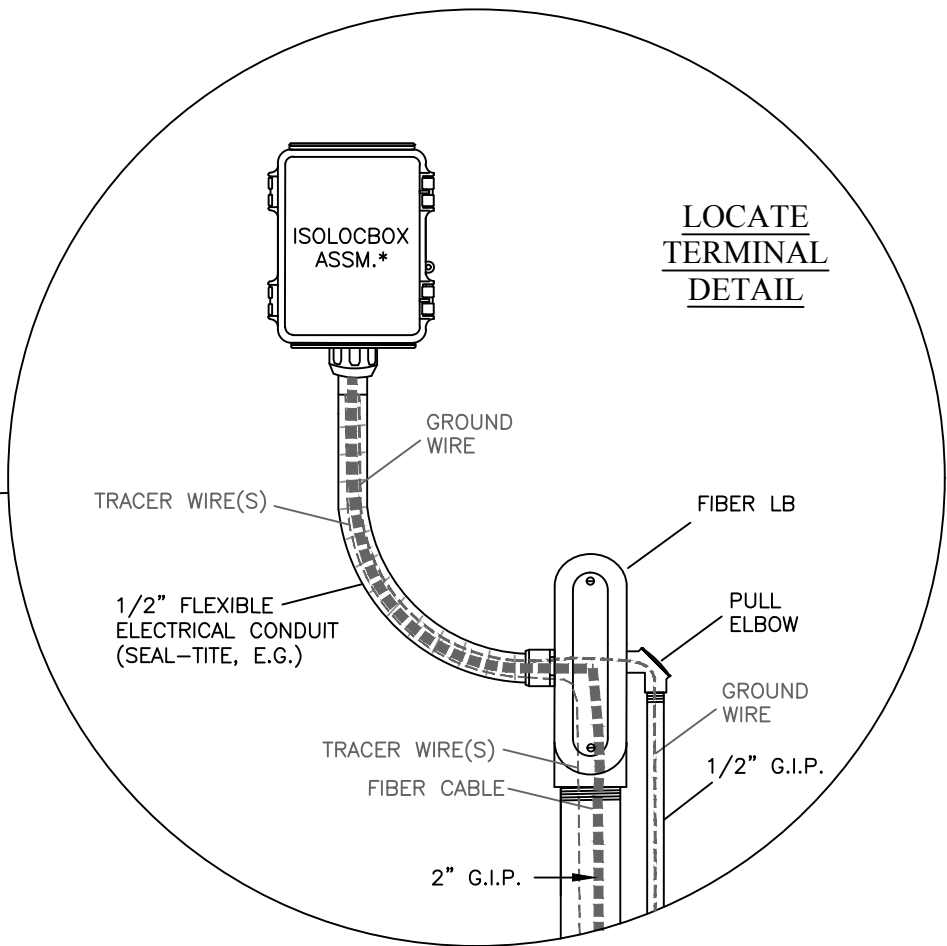
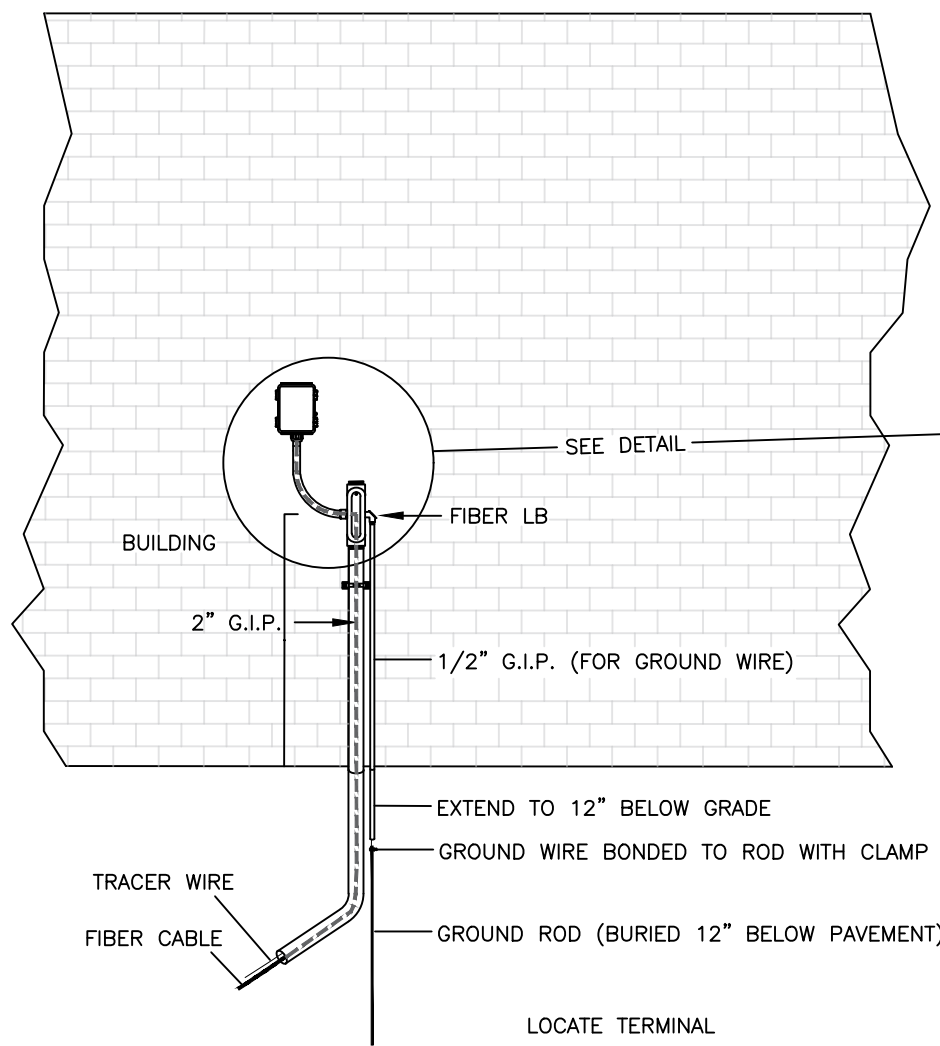
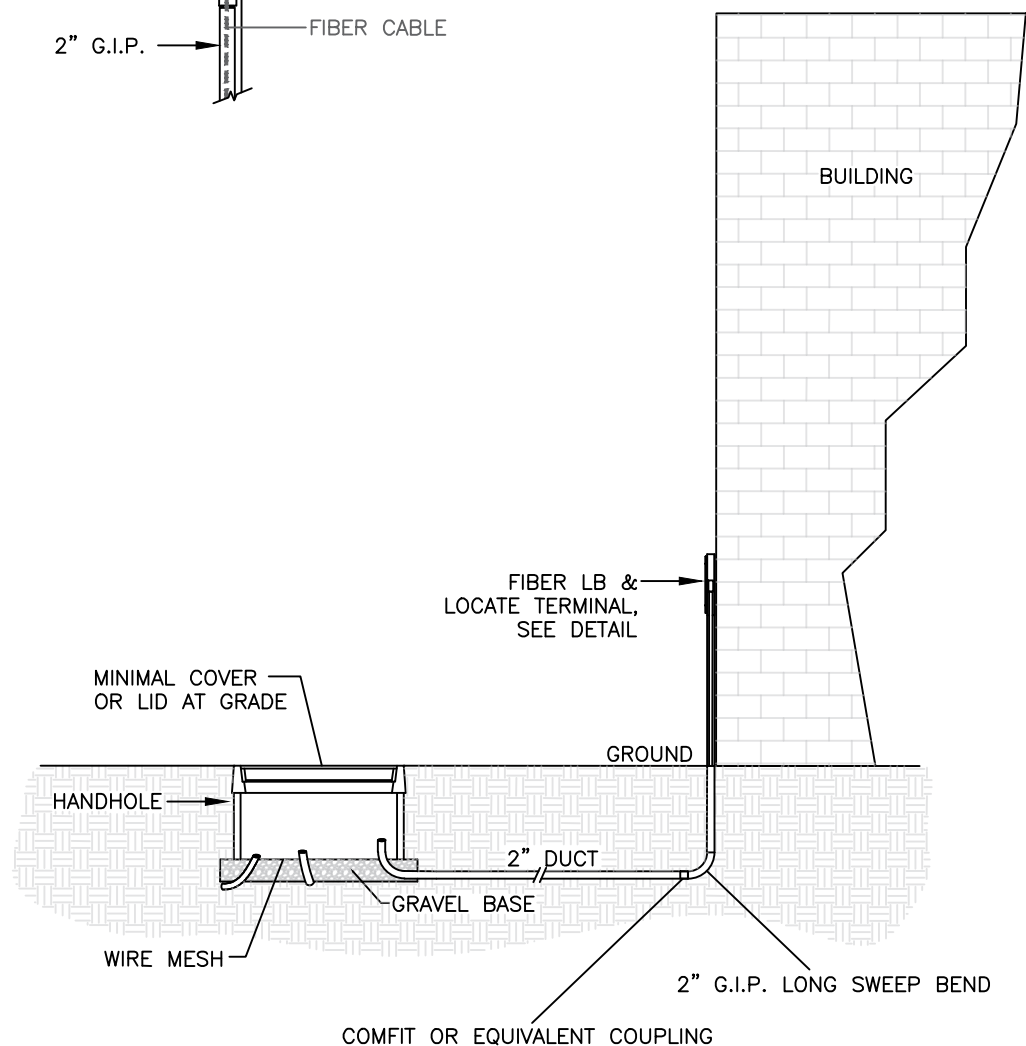

TRACER WIRE TERMINATION DETAIL

TERMINATION OF THE LOCATE WIRE AT A LOCATE PEDESTAL, LOCATE TERMINAL, OR IN A SPLICE CASE SHALL BE MADE IN THE FOLLOWING FASHION:  
STRIP OFF A MINIMUM OF 3/4" OF INSULATION. USING A NEEDLE NOSE PLIERS, BEND A WIRE "EYELET" ON THE WIRE END IN A CLOCKWISE MANNER. USE A FLAT WASHER ON BOTH SIDES OF THE WIRE EYELET WHEN CINCHING IT DOWN ON THE STUD. FLAT WASHERS SHALL BE OF APPROPRIATE SIZE SUCH THAT THE HOLE MATCHES THE DIAMETER OF THE STUD AND THE OUTSIDE OF DIAMETER OF THE FLAT WASHER MATCHES REASONBLY CLOSE TO THE EYELET DIAMETER.

LOCATE TERMINAL ISOLOCBOX ASSM.\*

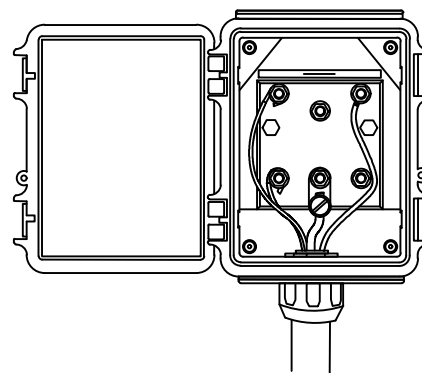

NOTES:

- (1) CORE HOLE THROUGH EXTERIOR WALL TO ACCOMMODATE 2" G.I.P.
- PLUG ALL DUCTS WITH JACK MOON OR EQUIVALENT
- BUILDING ENTRANCE SHALL HAVE WATER-TIGHT SEAL
- ANCHOR 2" G.I.P. TO WALL WITH 2-HOLE STRAPS, SPACED NO MORE THAN 5- FEET APART
- ALL COMPONENTS SHALL BE G.I.P. OR DIE CAST ALUMINUM
- EMT AND PLASTIC ARE NOT ALLOWED
- MOUNT LOCATE STATION A MINIMUM OF 18" ABOVE GRADE
- SEAL ANY ACCESS HOLES DRILLED IN THE LOCATE STATION TO ROUTE WIRES WITH SILICONE
- ALL COUPLINGS MUST ALLOW FOR BLOWING OR PULLING WITH NO OBSTRUCTION

\*NOTE: ISOLOCBOX ASSEMBLY INCLUDES: BOX, ISOLEVER, PVC STAND-OFF, AND 1-FT OF FLEXIBLE CONDUIT WITH CONNECTORS



ICN OSKALOOSA-PSAP CENTER TO EXISTING ICN HANDHOLE

1	90% REVIEW	7/27/2020
2	FINAL PLANS	7/29/2020
3		
4		

**hbk** **ICN**

**IOWA COMMUNICATIONS NETWORK**  
400 EAST 14TH STREET  
GRIMES STATE OFFICE BUILDING  
DES MOINES, IOWA 50319  
ICN © 2019, COPY WITH PERMISSION

# SPLIT WYE SPECIFICATIONS FOR HANDHOLE NO. 4

Conduit Repair Systems Catalog

## SPLIT WYE

For branching off of new or existing conduit lines.



CRS's Split WYE's are specifically designed to allow you to branch off of an existing conduit line while maintaining the full integrity of your underground infrastructure. The Split WYE's are manufactured from a UL approved PVC plastic that is specifically designed for power and communications applications. CRS's split WYE's are designed to be used with CRS's split couplings and CRS's split adapter couplings.



CRS's SPLIT WYE'S are ETL listed and meet the standards and specifications of UL 651.

Please note: CRS's Split Wye's are not self-locking. CRS's Split Wye's are designed to be held together by snapping a CRS Split Coupling or Split Adapter Coupling on each end of the split wye. CRS's Split Wye's can be used without CRS's Split Couplings, but will require the use of PVC cement, hose clamps or some other strap to hold the wye together.

Part #	Description
Y125F	1.25" Split WYE
Y2F	2" Split WYE
Y4F	4" Split WYE

## SPLIT WYE KITS



CRS's Split WYE Kits are the perfect way to go when you need to branch off of an existing conduit line. Each Split WYE Kit is prepackaged to include one split WYE and three of CRS's Split Adapter couplings.

CRS's SPLIT WYE KITS are ETL listed and meet the standards and specifications of UL 651.

Please note: You may request to replace the CRS Split Adapter Couplings with our standard CRS Split Couplings or any combination of Adapter Couplings and Split Couplings.

Part #	Description
Y125FK	1.25" Split WYE
Y2FK	2" Split WYE
Y4FK	4" Split WYE

To order call 1-800-670-1804, or fax 1-435-673-8724 10



ICN OSKALOOSA-PSAP CENTER TO EXISTING ICN HANDHOLE



1	90% REVIEW	7/27/2020
2	FINAL PLANS	7/29/2020
3		
4		

**IOWA COMMUNICATIONS NETWORK**  
 400 EAST 14TH STREET  
 GRIMES STATE OFFICE BUILDING  
 DES MOINES, IOWA 50319  
 ICN © 2019, COPY WITH PERMISSION

# HANDHOLE PLACEMENT TYPICAL

24" X 36" X 36" HAND HOLE

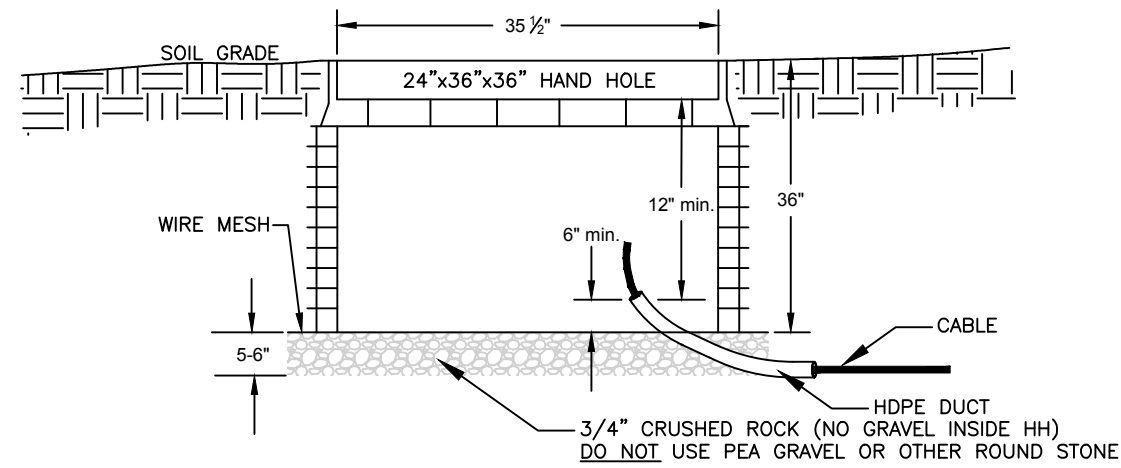

SEE INSTALLATION INSTRUCTIONS FOR PROPER PLACEMENT OF CHANNEL BULK HANDHOLE

TYPICAL TRIVIEW LOCATE PEDESTAL OR WARNING MARKER

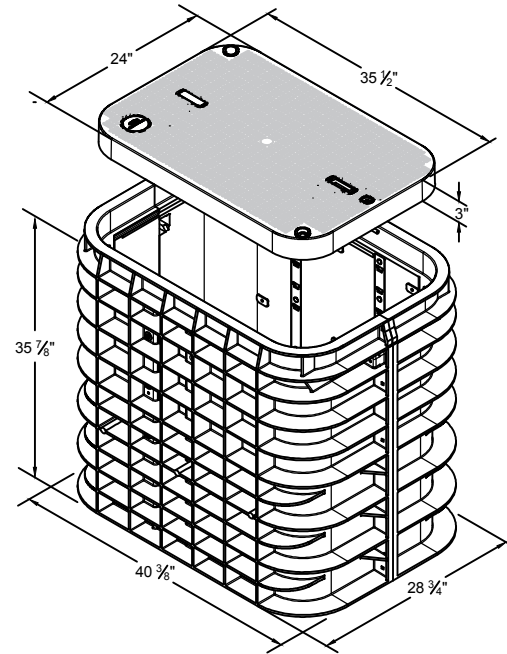
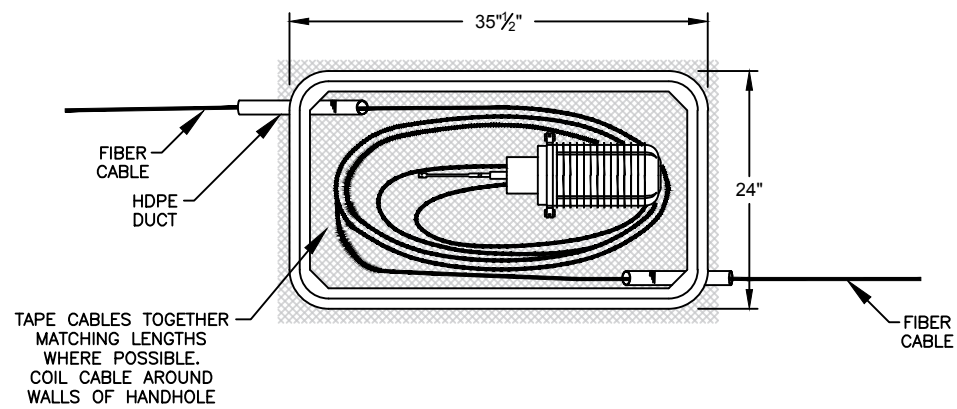

BULK HANDHOLE TYPICAL  
24" X 36" X 36"

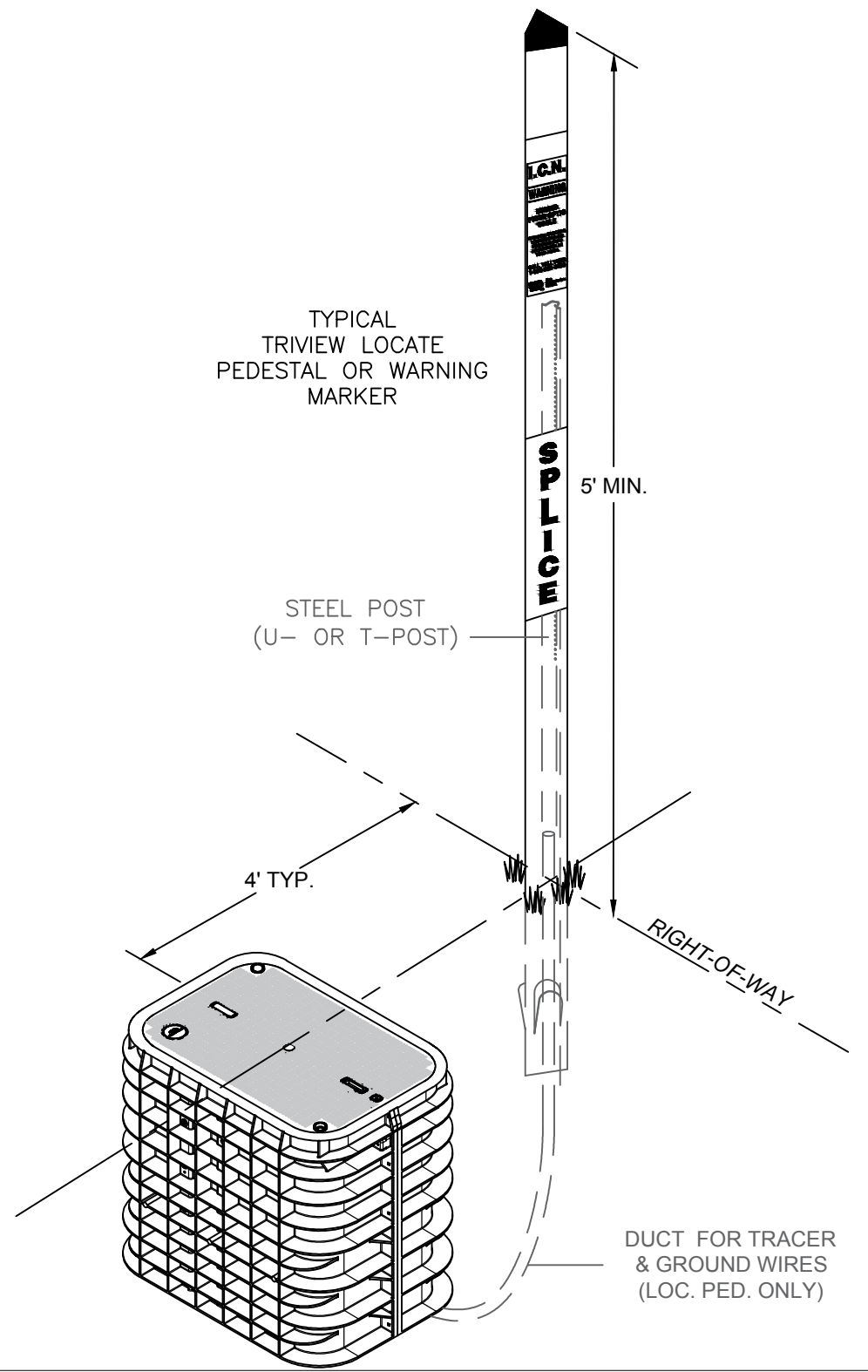

ICN OSKALOOSA-PSAP CENTER TO EXISTING ICN HANDHOLE

1	90% REVIEW	7/27/2020
2	FINAL PLANS	7/29/2020
3		
4		

**hbk** **ICN**

**IOWA COMMUNICATIONS NETWORK**  
400 EAST 14TH STREET  
GRIMES STATE OFFICE BUILDING  
DES MOINES, IOWA 50319  
ICN © 2019, COPY WITH PERMISSION



# INSTALLATION INSTRUCTION

## Install Channell BULK Vaults

Date: 5/12/15

### Installation Considerations

This Installation Instruction provides general information useful for installing the Channell BULK line of below-grade handhole vaults. This guide cannot anticipate all situations that could be encountered in the field and thus represents information applicable to common installation conditions. Please consult local company practice for proper product configuration for each application.

### Site Preparation

1. Ensure that all local, state, federal, OSHA and company-specific regulations are met prior to beginning and throughout the installation process.
2. Plan the excavation approximately 12 to 16 inches in length and width larger than the actual dimensions of the handhole to be installed. **(See Figure 1)**
3. Excavate the hole 6 to 8 inches in depth more than the overall height dimension of the handhole with the cover in place. Tamp the floor of excavated pit using either a hand tamp tool and/or a mechanical tamper. (Remember: if the handhole is to be set in concrete, the polymer ring must be included in this dimension.)
4. Place 5 to 6 inches of 3/4" crushed rock over the entire floor. The rock should be free of soil and other organic matter. This important step prevents subsistence of the vault over time, aids in drainage, and provides a solid foundation for the handhole. **(See Figure 2)**
  - a. As an alternative, a dry mix of cement and crushed rock in a 1:10 ratio may be used to form a higher strength foundation.
  - b. NOTE: Do not use "pea gravel" or other "round stone" for this step.
5.
  - a. Place the handhole body into the pit. **(See Figure 3)**
  - b. Center the handhole body in the excavated pit parallel to the sidewalk and/or curb if applicable.
  - c. Level and adjust the height of the handhole body to grade, as required, by adding more crushed rock.

FOR THE PURPOSE OF THIS ILLUSTRATION, THIS HANDHOLE IS BEING PLACED AT A SITE THAT WILL HAVE A FUTURE SIDEWALK; THEREFORE, THE COMPOSITE RING IS REQUIRED. THE RING IS ONLY REQUIRED AT SITES WHERE THE HANDHOLE IS BEING PLACED IN AND SURROUNDED BY CONCRETE.

6. Place the cover on the handhole body to prevent the backfill dirt from entering the inside of the handhole. The cover should be level with the ground. Bolting of the cover is recommend but is not a requirement for this step; however, the cover must always be bolted down prior to departure of the site. **(See Figure 4)**
7. The excess soil removed from the excavated pit shall be used during the backfill of the pit. The backfill shall be tamped continuously during the filling process to prevent settling around the sides of the handhole. **(See Figure 5)**

During the filling process of the soil around the handhole, stones that are 3" and larger shall be removed from the soil and not used.

8. The final backfill shall be tamped with a slope away from the handhole. All excess backfill material shall be removed from the installation site. **(See Figure 6)**



## Install Channell BULK Vaults

Figure 1



Figure 2



Figure 3



Figure 4



Figure 5



Figure 6



ICN OSKALOOSA-PSAP CENTER TO EXISTING ICN HANDHOLE

1	90% REVIEW	7/27/2020
2	FINAL PLANS	7/29/2020
3		
4		

**hbK** **ICN**  
**IOWA COMMUNICATIONS NETWORK**  
 400 EAST 14TH STREET  
 GRIMES STATE OFFICE BUILDING  
 DES MOINES, IOWA 50319  
 ICN © 2019, COPY WITH PERMISSION

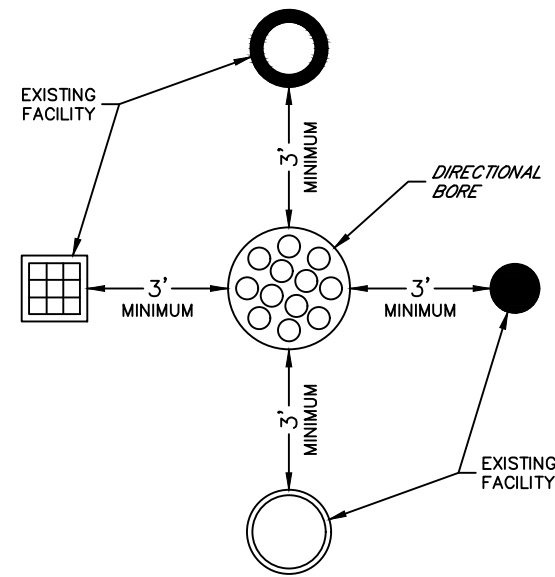

MAINTAIN A MINIMUM OF AT LEAST 3 FEET OF SEPARATION IN ANY DIRECTION BETWEEN DIRECTIONAL BORE AND ALL EXISTING FACILITIES.

UTILITY SEPARATION DETAIL

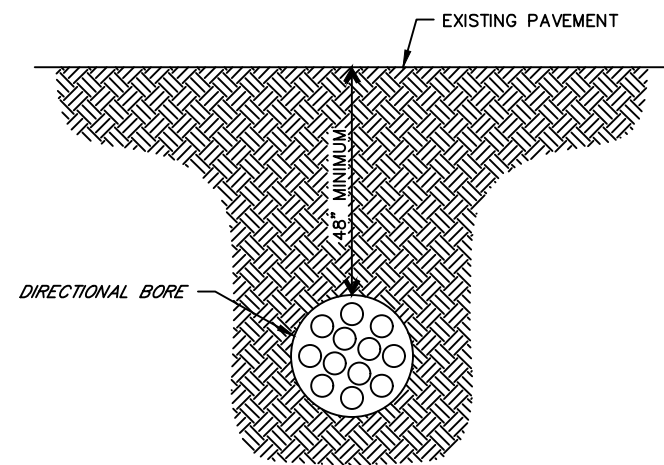

DIRECTIONAL BORING DETAIL

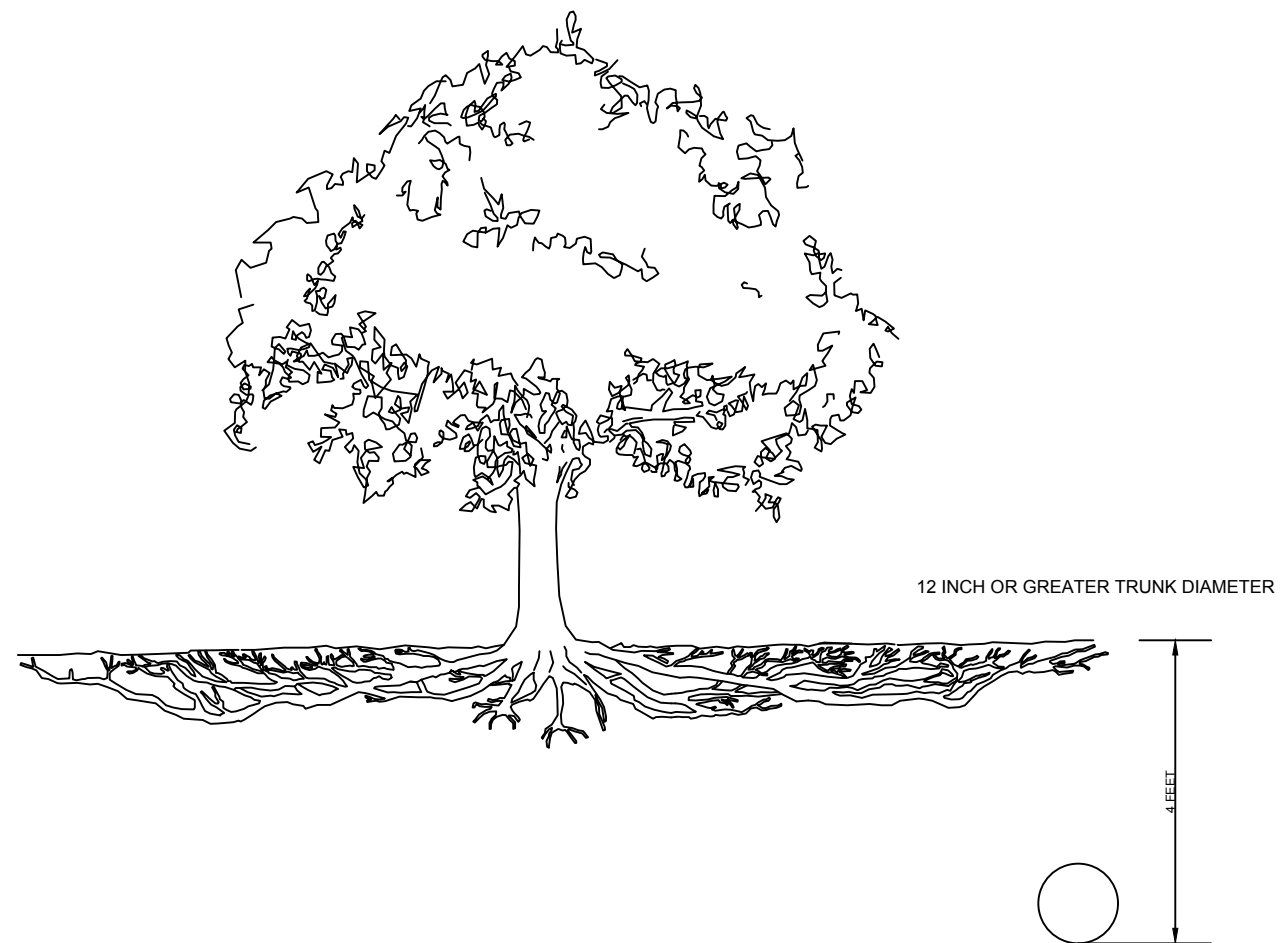

TREE PROTECTION - TUNNELING



ICN OSKALOOSA-PSAP CENTER TO EXISTING ICN HANDHOLE

1	90% REVIEW	7/27/2020
2	FINAL PLANS	7/29/2020
3		
4		

**hbk** **ICN**

**IOWA COMMUNICATIONS NETWORK**  
 400 EAST 14TH STREET  
 GRIMES STATE OFFICE BUILDING  
 DES MOINES, IOWA 50319  
 ICN © 2019, COPY WITH PERMISSION

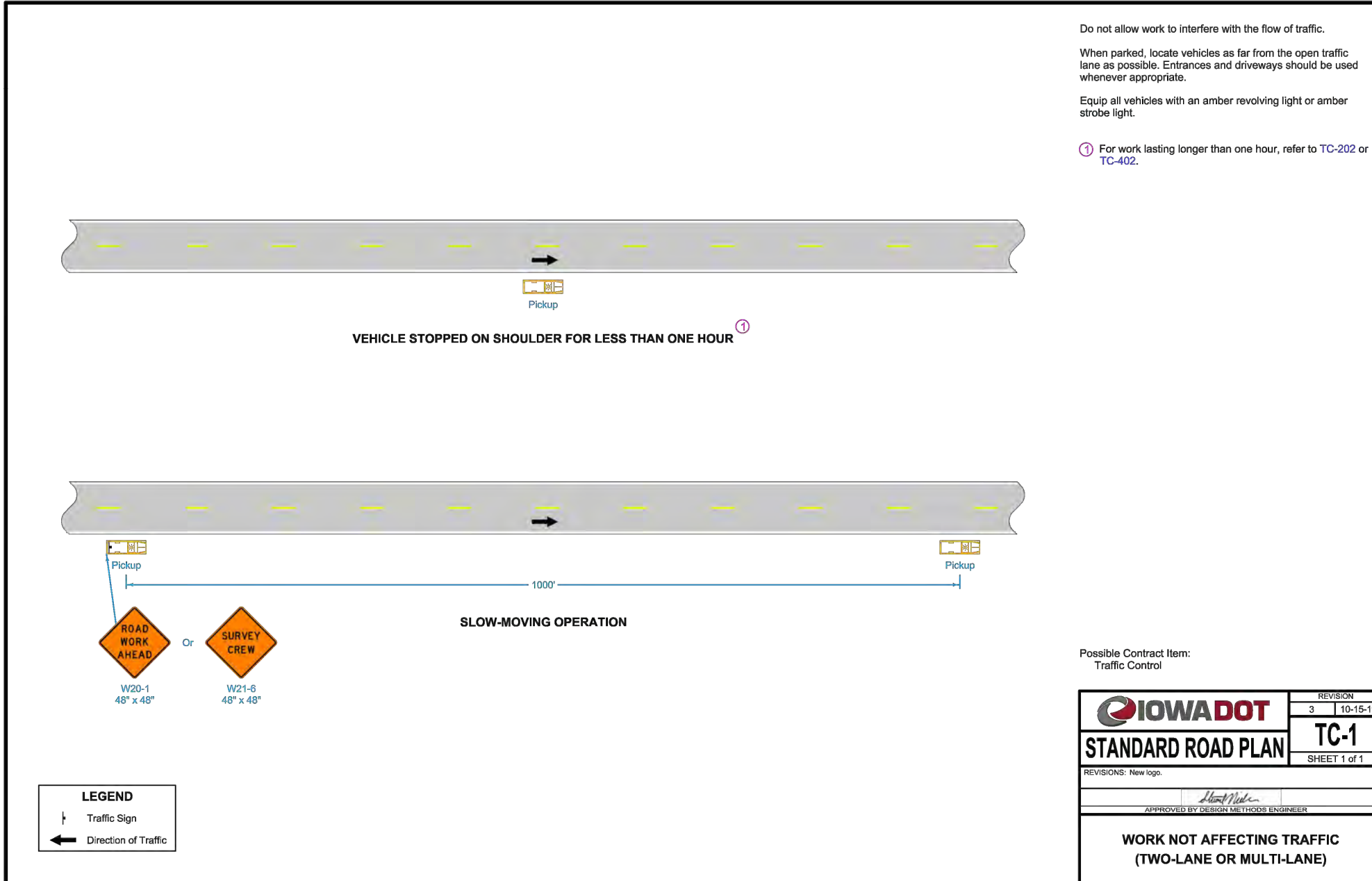

**LEGEND**  
 ↑ Traffic Sign  
 ← Direction of Traffic



ICN OSKALOOSA-PSAP CENTER TO EXISTING ICN HANDHOLE



1	90% REVIEW	7/27/2020
2	FINAL PLANS	7/29/2020
3		
4		

**IOWA COMMUNICATIONS NETWORK**  
 400 EAST 14TH STREET  
 GRIMES STATE OFFICE BUILDING  
 DES MOINES, IOWA 50319  
 ICN © 2019, COPY WITH PERMISSION

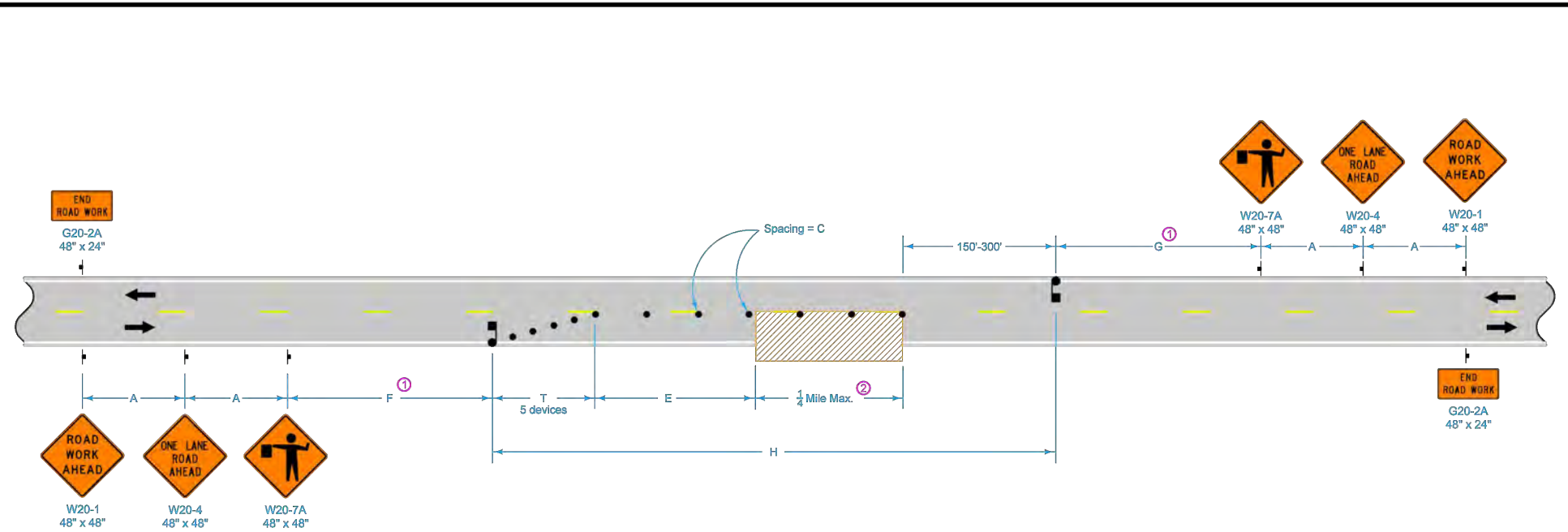

**LEGEND**

- T Traffic Sign
- Flagger
- 42" Channelizer
- ▨ Work Area
- ← Direction of Traffic

SPEED LIMIT (mph)	A	C	E	F and G Range	F + G Max.	H Max.	T
35 or less	250'	40'	0'-200'	500'-3000'	3500'	2000'	50'
40 - 45	350'	80'	0'-200'	700'-3000'	3700'	2000'	100'
50 or greater	500'	100'	200'-300'	1000'-3000'	4000'	2000'	100'

- ① Keep F and G distances as near to minimum values as work permits. However, to allow advancement of the work area without moving signs, F and G distances may be varied within the limits of the table. Maximum movement can be achieved by setting one F or G value at the minimum and the other value at its maximum.
- ② If length of work area exceeds 1/4 mile, use TC-214.

Possible Contract Items:  
 Flaggers  
 Traffic Control

**IOWA DOT**

**STANDARD ROAD PLAN**

REVISIONS: New logo.

APPROVED BY DESIGN METHODS ENGINEER

**LANE CLOSURE WITH FLAGGERS**

REVISION	DATE
4	10-15-19

TC-213  
SHEET 1 of 1



ICN OSKALOOSA-PSAP CENTER TO EXISTING ICN HANDHOLE

NO.	DESCRIPTION	DATE
1	90% REVIEW	7/27/2020
2	FINAL PLANS	7/29/2020
3		
4		

**hbk** **ICN**

**IOWA COMMUNICATIONS NETWORK**  
 400 EAST 14TH STREET  
 GRIMES STATE OFFICE BUILDING  
 DES MOINES, IOWA 50319  
 ICN © 2019, COPY WITH PERMISSION