

**ADDENDUM #1**

**IUB HEARING ROOM REMODEL**  
DAS PROJECT NO. 9027.00

BID DATE: October 11, 2018, 2:00 P.M. CENTRAL TIME

---

The information contained in this Addendum modifies, supplements or replaces information contained in the Project Manual and on the Drawings and is hereby made a part of the Contract Documents.

Acknowledge receipt of this Addendum by placing the appropriate addendum number in the blank on the Bid Form.

---

**ADDENDUM INDEX**

APPLICABLE TO THE PROJECT MANUAL:	Item #1 through Item #3 inclusive.
APPLICABLE TO THE DRAWINGS:	Item #4 through Item #11 inclusive.
ATTACHMENT(S):	Section 00 01 07 Section 00 41 16 Sheet ES-01 Sheet ES-02 Sheet ES-03 Bidder Questions for reference Pre-Bid Meeting Minutes for reference

---

APPLICABLE TO THE PROJECT MANUAL:

- ITEM #1 SECTION 00 01 07 – SEALS PAGE
- A. **REPLACE** section with attached.
- ITEM #2 SECTION 00 41 16 – BID FORM
- B. **REPLACE** section with attached.
- ITEM #3 SECTION 01 12 00 – CONTRACT SUMMARY
- C. **ADD** section 1.09, G., to contract documents:
- G. **Alternate #05** – CONFERENCE ROOM CARPET  
REPLACEMENT: Trade Contractor shall include all of the following, but not limited to, as part of the contract:
1. Demolition and replacement of carpet tile and wall base in conference rooms. Salvage and clean Dark colored carpet for Owner's Attic Stock.
  2. Include as part of each alternate, miscellaneous devices, accessory objects, and similar items incidental to or required for a complete installation whether or not indicated as part of alternate.
  3. Execute accepted alternates under the same conditions as other work of the Contract.

APPLICABLE TO THE DRAWINGS:

- ITEM #4 G000 – COVER
- A. **REVISE** Drawing List as follows:
- ADD:  
E301 – Technology Plan  
E501 – Technology Details  
AV302 – AV Equipment Details  
AV303 – AV Equipment Details
- REMOVE:  
T101 – Technology Plan  
T301 – Technology Details
- ITEM #5 ELECTRICAL DRAWINGS – GENERAL NOTES:
- A. ALL ANCHORS INTO EXISTING ACOUSTICAL DECK TO UTILIZE EPIC DECK DOVETAIL WEDGE FASTENING SYSTEM TO MATCH EXISTING CONDITIONS.

- B. NEW CABLING AND RACEWAY ABOVE CEILING CLOUDS SHOULD FOLLOW EXISTING CABLING ROUTING PATHWAYS. WHEN NOT CONCEALED BY CEILING CLOUDS, CABLING SHALL BE INSTALLED IN CONDUIT.
- C. PAINT ALL NEW CONDUIT, JUNCTION BOXES, AND FASTENERS WHERE EXPOSED, COORDINATE FINAL COLOR WITH ARCHITECT.

ITEM #6 ED101 HEARING ROOM PLAN – DEMOLITION

- B. **CLARIFICATION** – Remove existing panic button and prepare for relocation into new board desk, coordinate final location with architect.
- C. **CLARIFICATION** – Existing in-floor electrical duct is Filges “203F” series system – it is not a continuously accessible trench. Fourplex box indicated on drawing represents a Filges “203F-JB” junction box.

ITEM #7 E301 HEARING ROOM PLAN – TECHNOLOGY

- A. **ADD** – Relocate existing panic button to new board desk mill work. ADD new panic button to the technology desk, extend wiring from both panic buttons back to existing emergency response system.
- B. **MODIFY** – New SPKR.1 (typ. x16) moved from structure to acoustic panels and type changed from suspended pendant to ceiling mount. New SPKR.2 (typ. X2) to be installed at existing location above board desk. Refer to supplemental sketch ES-02. Coordinate final location with architect prior to installation.
- C. **CLARIFICATION** – Telecom system CAT6 cabling to floor boxes AV4, AV5, AV6 and AV7 shall be routed via underfloor electrical duct. AV system cabling to floor boxes must be routed separately via pathway indicated between millwork and IT closet.

ITEM #8 E501 – TECHNOLOGY DETAILS

- A. **CLARIFICATION** – Rough-in Schedule added to sheet E501, refer to supplemental sketch ES-01.

ITEM #9 AV101 HEARING ROOM PLAN – AV EQUIPMENT

- A. **ADD** – CTRL.2 (Crestron DGE-100) for control of Technology Desk touch screen TOUCH.1
- B. **ADD** – (2) CTRL.3 (Crestron C2N-IO) modules at rack for powered shade control in conference rooms. Utilize last available relays on CTRL.1 for hearing room shades. Refer to supplemental sketch 2/ES-03 for details.

ITEM #10 AV201 – AV EQUIPMENT SCHEDULE

- A. **CLARIFICATION** – CTRL.1 description to be changed to read, “AV SYSTEM CONTROL PROCESSOR”.
- B. **CLARIFICATION** – PROJ.1 description to be changed to read, “WUXGA 3LCD W/ 4K ENHANCEMENT, 7,000 LUMENS”.
- C. **CLARIFICATION** – SPKR.1 model # to be changed to C45C/T and description to be changed to read, “70V, 30W, TWO-WAY 5.25” COAXIAL CEILING LOUDSPEAKER”.
- D. **CLARIFICATION** – Updated AV EQUIPMENT SCHEDULE to show CTRL.2, CTRL.3, PC.1, PC.2, PC.3, & SPKR.2. Refer to supplemental sketch ES-01.

ITEM #11 AV301 – AV EQUIPMENT DETAILS

- A. **CLARIFICATION** – Modify VIDEO SIGNAL FLOW DIAGRAM to show CTRL.2 @ technology desk between TOUCH.1 and SW.1. Refer to 1/ES-03 for details.
- B. **CLARIFICATION** – Modify CONTROL SIGNAL FLOW DIAGRAM to show CTRL.3 for powered shade control. Refer to 1/ES-03 for details.

APPROVAL OF ADDITIONAL PRODUCTS/SYSTEMS:

The following shall be added to specifications as approved manufacturers:

<u>Type</u>	<u>Manufacturer</u>
Light Fixture F1	Cree, Pathway
Light Fixture F2	Alight
Light Fixture F3	Alight
Wireless Lighting Control	Crestron

**END OF ADDENDUM**

**SECTION 00 0107**

**SEALS PAGE**

I hereby certify that the portion of this technical submission described below was prepared by me or under my direct supervision and responsible charge.

Discipline: Architect Stamp: \_\_\_\_\_  
Company Name: BNIM  
Address: 317 6th Ave Suite 100, Des Moines IA 50309  
Telephone: 515-974-6462  
Name: Carey Nagle Responsibility: Sheets G, AD, A  
License#: 06158 Divisions: 05,06,09

I hereby certify that the portion of this technical submission described below was prepared by me or under my direct supervision and responsible charge.

Discipline: Electrical Engineer Stamp: \_\_\_\_\_  
Company Name: KCL Engineering  
Address: 300 4th ST, West Des Moines IA 50265  
Telephone: 515-724-7938  
Name: James R. Deeds IV Responsibility: Sheets E, ED, AV  
License#: 17588 Divisions: 26, 27, 28

**END OF SECTION**

**SECTION 00 4116**

**BID FORM**

RFB #0919335023

BID FORM for CONSTRUCTION CONTRACT  
for  
Iowa Utilities Board  
1375 E Court Avenue, Des Moines, Iowa  
Project 9027.00

Iowa Department of Administrative Services  
GSE-Central Procurement Bureau  
Hoover State Office Building, Level 3  
1305 East Walnut Street  
Des Moines, Iowa 50319-0105

The following documents are to be completed and submitted with your bid.

1. Bid Proposal Form (Required)
2. Non Discrimination Clause Form
3. Contractor Targeted Small Business Enterprise Pre-Bid Contract Information Form
4. Bid Security – 5% of total Bid amount (Is to be submit in separate envelope) (Required)
5. AV Bid Package #2 Only – Lease Agreement Proposal
6. AV Bid Package #2 Only – Maintenance Agreement Proposal

**Authorized Representative:**

The undersigned Bidder, in response to your Request for Bid for construction of the above project, having examined the Drawings, Specifications, and other Bidding Documents dated September 14, 2018, and Addenda issued and acknowledged below as received and being familiar with all the conditions surrounding the construction of the proposed project including the availability of materials and labor, hereby proposes to furnish all labor, materials, equipment and supplies to perform all work to construct the project in strict accordance with the proposed Contract Documents, within the time and at the prices stated below. Prices are to cover all expenses incurred in performing the work required under the proposed Contract Documents, of which this bid is a part.

Bidder acknowledges receipt of the following Addenda which are a part of the Bidding Documents and for which any effect on cost of the Work is included in the bid amounts indicated:

Number	_____	_____	_____	_____	_____
Dated	_____	_____	_____	_____	_____

Note that the State of Iowa is exempt from State and Local sales and use taxes (including local option and school option) for this project. Taxes on construction materials shall NOT be included in the bid amounts.

Amounts shall be indicated in both words and figures. In case of discrepancy, the amount indicated in words shall govern.

BID PACKAGES:

BP 01

Description: General – See section 01 1200 for scope description.

Bidder proposes and agrees to perform all work as described in the Construction Documents for the sum of:

\_\_\_\_\_ Dollars

(\$\_\_\_\_\_).

BP 02

Description: AV Lease with Install – See section 01 1200 for scope description.

Bidder proposes and agrees to perform all work as described in the Construction Documents for the sum of:

\_\_\_\_\_ Dollars

(\$\_\_\_\_\_).

ALTERNATES:

ALT 01

Description: AV Equipment Purchase with Install – See section 01 1200 for scope description.

Bidder proposes and agrees to perform all work as described in the Construction Documents for the sum of:

\_\_\_\_\_ Dollars

(\$\_\_\_\_\_).

ALT 02

Description: AV System Service Agreement – See section 01 1200 for scope description.

Bidder proposes and agrees to perform all work as described in the Construction Documents for the sum of:

\_\_\_\_\_ Dollars

(\$\_\_\_\_\_).

ALT 03

Description: LED Lighting Upgrade – See section 01 1200 for scope description.

Bidder proposes and agrees to perform all work as described in the Construction Documents for the sum of:

\_\_\_\_\_ Dollars

(\$\_\_\_\_\_).

ALT 04

Description: Conference Room Scheduling Tablets – See section 01 1200 for scope description.

Bidder proposes and agrees to perform all work as described in the Construction Documents for the sum of:

\_\_\_\_\_ Dollars

(\$\_\_\_\_\_).

ALT 05

Description: Conference Room Carpet Replacement – See section 01 1200 for scope description.

Bidder proposes and agrees to perform all work as described in the Construction Documents for the sum of:

\_\_\_\_\_ Dollars

(\$\_\_\_\_\_).

Bidder hereby certifies that:

1. This bid is genuine and is not made in the interest of or on behalf of any undisclosed person, firm or corporation;
2. Bidder has not directly or indirectly induced or solicited any other bidder to put in a false or sham bid; Bidder has not solicited or induced any person, firm or corporation to refrain from bidding; and Bidder has not sought by collusion to obtain any advantage over any other bidder or over the Owner.
3. Bidder hereby certifies that the Bidder is registered with the Iowa Labor Commissioner as a Contractor as required by Chapter 91C, Code of Iowa.
4. Bidder agrees to comply with all Federal and State Affirmative Action/Equal Employment Opportunity requirements concerning fair employment and will not discriminate between or among them by reason of race, color, religion, sex, national origin or physical handicap.
5. All construction under this Contract shall conform to the requirements of the *Iowa State Building Code*.
6. Bidder agrees that this bid shall remain valid and shall not be withdrawn for a period of thirty (30) calendar days after the date for receipt of bids.
7. Bidder agrees that if written notice of acceptance of this bid is mailed, emailed, or delivered to the undersigned within thirty (30) days after the date in which bids are due, or at any time thereafter before it is withdrawn, the undersigned will sign and return the Contract Agreement, prepared in accord with the Bidding Documents and this bid as accepted; and will also provide proof of insurance coverage and required surety bonds.
8. Bidder understands that the Owner reserves the right to reject any and all bids, and to waive irregularities or informalities and enter into a contract for the work, as the Owner deems to be in the best interest of the State.
9. Bidder understands that the Owner reserves the right to accept any, or no, Alternate Bid, if requested, and that the Alternate Bids may be considered in any order or combination, and the low Bidder shall be determined on the basis of the sum of the base bid and any Alternate(s) accepted.

Subcontractors:

The Trade Contractor must identify all Subcontractors and Suppliers within 48 hours of the published date and time for which bids must be submitted, in accordance with Iowa Code Section 8A311, as amended by House File 646 in 2011. Subcontractors and suppliers may not be changed without the approval of the Owner. Requests for changing a Subcontractor or supplier must identify the reason for the proposed change, the name of the new Subcontractor or supplier, and the change in the subcontractor or supplier price as a result of the change. Any reduction in subcontractor or supplier price as a result of the change, if the change is approved by the Owner, shall be deducted from the Trade Contract Price via a deductive Change Order. Any such changes, if approved by the Owner, which result in an increase in the Trade Contract Price shall be borne by the Trade Contractor.

**Enforcement of Reciprocal Resident Bidder Preference, per Iowa Code 73A.21.**

All bidders shall either check the box next to "Resident Bidder" or check the box next to "Nonresident Bidder" and by doing so and signing thereafter certifies and attests to the same. All information requested must be provided. Seek out the advice of an attorney if you have questions.

"Resident Bidder" means a person or entity authorized to transact business in of the State of Iowa and having a place of business for transacting business within the State of Iowa at which it is conducting and has conducted business for at least three years prior to the date of the first advertisement for the public improvement. Note, however, that if a nonresident bidder's state or foreign country has a more stringent definition of a resident bidder, the more stringent definition is applicable as to bidders from that state or foreign country.

Resident Bidder

Name of Resident Bidder: \_\_\_\_\_

By: \_\_\_\_\_  
Authorized Agent and Signatory of Resident Bidder

**OR:**

Nonresident Bidder

Name of Nonresident Bidder: \_\_\_\_\_

Name of State or Foreign Country of Nonresident Bidder: \_\_\_\_\_

Particularly identify and describe any preference, labor preference, or any other type of preferential treatment, in effect in the nonresident bidder's state or foreign country at the time of this bid:

\_\_\_\_\_  
\_\_\_\_\_  
\_\_\_\_\_

**NOTICE:** Nonresident Bidders domiciled in a state or country with a resident labor force preference shall make and keep, for a period of not less than three years, accurate records of all workers employed on the public improvement. The records shall include each worker's name, address, telephone number when available, social security number, trade classification, and the starting ending time of employment.

By: \_\_\_\_\_  
Authorized Agent and Signatory of Nonresident Bidder

Bid Form shall be signed by an officer of the company with authority to bind in a contract. Notice of acceptance of this bid, or request for additional information by the Department of Administrative Services, may be addressed to the undersigned at the address set forth below:

Legal Name of Firm: \_\_\_\_\_

Date: \_\_\_\_\_

Signature of Bidder: \_\_\_\_\_

Title: \_\_\_\_\_

Typed Name of Signatory: \_\_\_\_\_

Email: \_\_\_\_\_

Business Address:

\_\_\_\_\_  
\_\_\_\_\_  
\_\_\_\_\_

Telephone Number: \_\_\_\_\_ Fax Number: \_\_\_\_\_

Federal Tax Identification Number: \_\_\_\_\_















Iowa Contractor Registration Number: \_\_\_\_\_

Bidder Safety Manager Name: \_\_\_\_\_



For an out-of-state Bidder, Bidder certifies that the Resident Preference given by the State or  
Foreign Country of Bidder's residence, \_\_\_\_\_, is \_\_\_\_\_ %.

**END OF SECTION**

**ROUGH-IN SCHEDULE**

SYMBOL	SERVICE	DESCRIPTION	ROUGH-IN NOTES
 AV-1	BOARD DESK	JUNCTION BOX EQUAL TO RACO 239 SERVING AV OUTPUT & WIRED AUDIO INFRASTRUCTURE TO BOARD DESK. (1) CAT6, (1) AV CAT6, & (1) XLR	MOUNT JUNCTION BOXES ON VERTICAL FACE IN DESK TROUGH, COORDINATE LOCATION WITH ARCHITECT.
 AV-2	BOARD DESK	JUNCTION BOX EQUAL TO RACO 239 SERVING AV OUTPUT & WIRED AUDIO INFRASTRUCTURE TO BOARD DESK. (1) CAT6, (1) AV CAT6, & (1) XLR	MOUNT JUNCTION BOXES ON VERTICAL FACE IN DESK TROUGH, COORDINATE LOCATION WITH ARCHITECT.
 AV-3	TECH WORKSTATION	JUNCTION BOX EQUAL TO RACO 239 FOR SERVING INFRASTRUCTURE TO TECHNOLOGY DESK. (2) CAT6	INSTALL JUNCTION BOX ABOVE DESKTOP, COORDINATE FINAL LOCATION WITH ARCHITECT.
 AV-4	FLOOR BOX	FLOOR BOX SERVING INFRASTRUCTURE TO COURT REPORTER DESK. (1) CAT6 & (1) AV CAT6	
 AV-5	FLOOR BOX	FLOOR BOX SERVING AV INPUT & WIRED MICROPHONE INFRASTRUCTURE. (1) CAT6, (1) AV CAT6, & (2) XLR	RE-USE EXISTING FLOOR BOX ROUGH-IN LOCATIONS WHERE POSSIBLE.
 AV-6	FLOOR BOX	FLOOR BOX SERVING AV INPUT & WIRED MICROPHONE INFRASTRUCTURE. (1) CAT6, (1) AV CAT6, & (2) XLR	RE-USE EXISTING FLOOR BOX ROUGH-IN LOCATIONS WHERE POSSIBLE.
 AV-7	FLOOR BOX	FLOOR BOX SERVING INFRASTRUCTURE TO TABLES. (1) CAT6 & (1) AV CAT6	
 AV-9	CONFERENCE RM FLOOR BOX	EXISTING FLOOR BOX FOR SERVING AV INPUT INFRASTRUCTURE. ONE (1) HDMI JACK FACE PLATE. (1) CAT6 & (1) AV CAT6	RE-USE EXISTING FLOOR BOX, PULL NEW CABLING TO LOCATION AND INSTALL NEW FACEPLATES.
 AV-10	AUDIO WALL BOX	3-GANG JUNCTION BOX FOR SERVING WIRED AUDIO INFRASTRUCTURE TO PRESS/AUDIENCE. SIX (6) XLR FACE PLATE.	
 AV-11	HDMI IN WALL PLATE	JUNCTION BOX SERVING AV INPUT INFRASTRUCTURE. CRESTRON HD-TXC-101 WITH (1) SHIELDED CAT6A CABLE BACK TO RACK.1	RE-USE EXISTING ROUGH-IN LOCATION
 P-1	PROJECTOR	JUNCTION BOX EQUAL TO RACO 239 FOR SERVING AV OUTPUT TO THE PROJECTOR. (1) CAT6 & (1) AV CAT6	RE-USE EXISTING ROUGH-IN LOCATION
 PS-1	PROJECTOR SCREEN	JUNCTION BOX EQUAL TO RACO 239 SERVING POWER AND RELAY CONTROL TO MOTORIZED PROJECTOR SCREEN.	RE-USE EXISTING ROUGH-IN LOCATION
 TS-1	TOUCHPAD	JUNCTION BOX EQUAL TO RACO 239 SERVING AV I/O FOR THE HEARING ROOM MASTER CONTROL TOUCHPAD. (2) AV CAT6	INSTALL JUNCTION BOX BELOW DESKTOP, COORDINATE FINAL LOCATION WITH ARCHITECT.
 TS-2	TOUCHPAD	JUNCTION BOX EQUAL TO RACO 239 SERVING AV INPUT, CCTV CONTROL, AND VIDEO CONTROL TOUCHPAD. (2) AV CAT6	INSTALL JUNCTION BOX BELOW DESKTOP, COORDINATE FINAL LOCATION WITH ARCHITECT.
 TS-3	TOUCHPAD	JUNCTION BOX EQUAL TO 239 SERVING AV INPUT AND POWER FOR THE WITNESS DESK ANNOTATIVE TOUCHPAD. (1) CAT6 & (1) AV CAT6	INSTALL JUNCTION BOX BELOW DESKTOP, COORDINATE FINAL LOCATION WITH ARCHITECT.
 TS-4	TOUCHPAD	EXISTING JUNCTION BOX FOR SERVING NEW DATA TO THE CONFERENCE ROOM CONTROL TOUCHPAD. (1) AV CAT6	RE-USE EXISTING TOUCH PANEL ROUGH-IN LOCATION, RE-USE JUNCTION BOX IF POSSIBLE.
 TS-5	TOUCHPAD	JUNCTION BOX EQUAL TO 233 SERVING DATA TO THE ROOM SCHEDULING TOUCHPAD. (1) CAT6	INSTALL AT 48" ABOVE FINISHED FLOOR, COORDINATE FINAL LOCATION WITH ARCHITECT.
 M-1	MONITOR	JUNCTION BOX EQUAL TO 239 SERVING AV OUTPUT TO OWNER PROVIDED DESKTOP PC. (1) CAT6 & (1) AV CAT6	MOUNT JUNCTION BOXES ON VERTICAL FACE IN BOARD DESK TROUGH, COORDINATE LOCATION WITH ARCHITECT.
 M-2	MONITOR	FSR PWB-270 JUNCTION BOX FOR SERVING POWER & AV OUTPUT TO 70" MONITOR. (1) CAT6 & (1) AV CAT6	INSTALL AT 72" ABOVE FINISHED FLOOR, COORDINATE WITH ARCHITECT FOR FINAL ROUGH-IN LOCATION.
A.	COORDINATE WITH ARCHITECTURAL PLANS AND ELEVATIONS FOR ALL FINAL ROUGH-IN LOCATIONS.		
B.	THE INTENT OF THIS SCHEDULE IS TO IDENTIFY ALL MAJOR COMPONENT'S ROUGH-IN AND PATHWAY NEEDS. PROVIDE ALL OTHER APPROPRIATE PATHWAYS TO COMPONENTS THAT MAY NOT BE ILLUSTRATED HERE IN ORDER TO DELIVER A FULLY FUNCTIONAL SYSTEM.		
C.	NO SINGLE CONDUIT RUN SHALL EXCEED 100 FEET OR MORE THAN TWO 90 DEGREE BENDS. PROVIDE INTERMITTENT PULL BOXES BEFORE EITHER OF THESE PARAMETERS ARE EXCEEDED.		

AV EQUIPMENT SCHEDULE ADDITIONS:

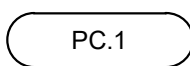
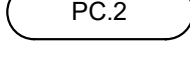
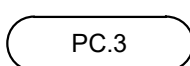
SYMBOL	MANUFACTURER	MODEL	DESCRIPTION
 CTRL.2	CRESTRON	DGE-100	GRAPHICS ENGINE FOR PLANAR TOUCH SCREEN
 CTRL.3	CRESTRON	C2N-IO	CONTROL PORT EXPANSION MODULE
 PC.1  PC.2	N/A	N/A	Minimum performance requirements: Processor: 8th Generation Intel® Core™ i5, 3.00 GHz, DDR4 Support Memory: 16 GB DDR4 Hard drive: 512 GB SSD Graphic Card: NVIDIA® QUADRO® P1000 (4 GB GDDR5 dedicated) Network Interface Card: (1) RJ45 @ 1Gbps Wi-Fi® and Bluetooth®: n/a Operating system: Windows 10 Pro  **PROVIDED BY OWNER, INSTALLED BY AV CONTRACTOR**
 PC.3	N/A	N/A	Minimum performance requirements: Processor: 8th Generation Intel® Core™ i5, 3.00 GHz, DDR4 Support Memory: 16 GB DDR4 Hard drive: 512 GB SSD Graphic Card: NVIDIA® QUADRO® P1000 (4 GB GDDR5 dedicated) Network Interface Card: (1) RJ45 @ 1Gbps Wi-Fi® and Bluetooth®: n/a Operating system: Windows 10 Pro  **PROVIDED AND INSTALLED BY AV CONTRACTOR**

Sheet  
**ES-01**  
Revision to Drawing:  
MULTIPLE

Project No.: 16045.01  
Addendum No.: 1  
Date: 10/05/2018

IUB - Hearing Room Remodel  
DAS No. 9027.00  
1375 E. Court Avenue  
Des Moines, IA 50319

KCL Engineering  
300 4th Street  
West Des Moines, Iowa 50265  
515.724.7938

LABEL	MANUFACTURER	MODEL	DESCRIPTION
SPKR.1	JBL	C45C/T	70V, 30W, TWO-WAY 5.25" COAXIAL CEILING LOUDSPEAKER
SPKR.2	JBL	C65P/T	70V, 30W, COMPACT FULL-RANGE PENDANT SPEAKER

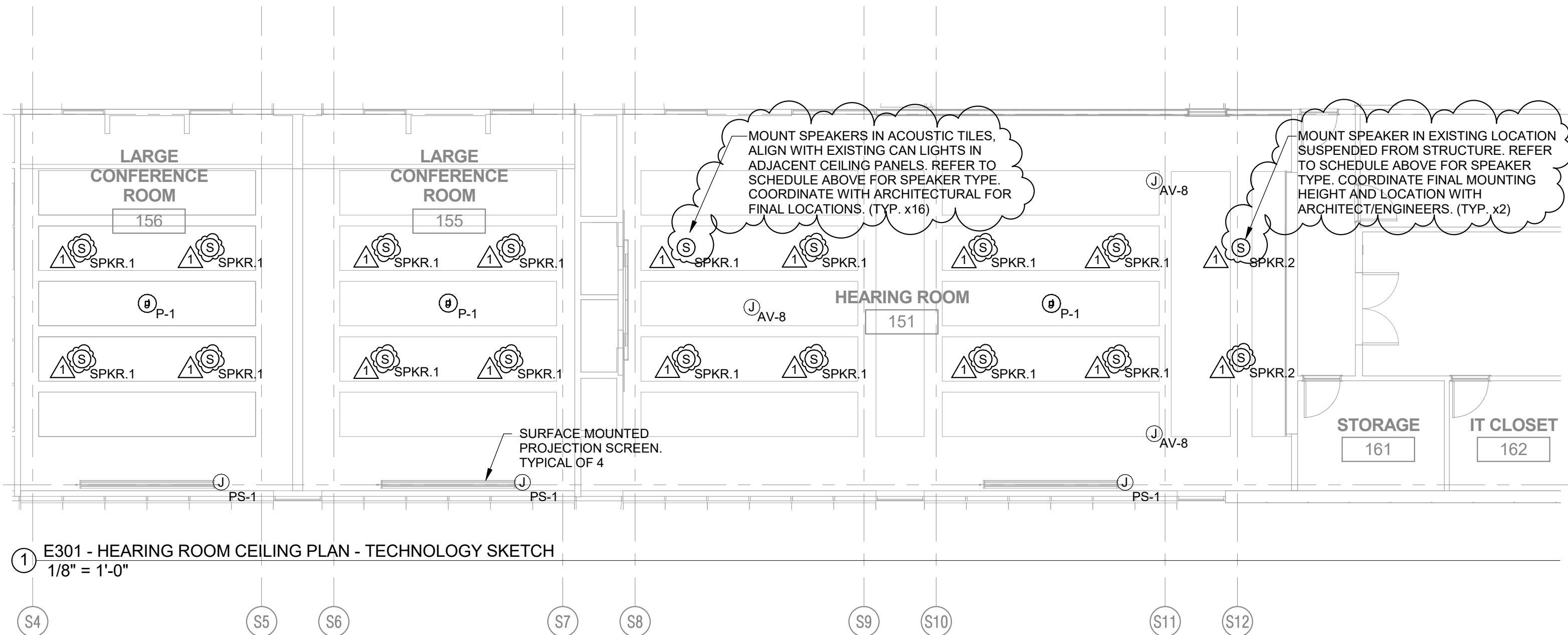

① E301 - HEARING ROOM CEILING PLAN - TECHNOLOGY SKETCH  
1/8" = 1'-0"

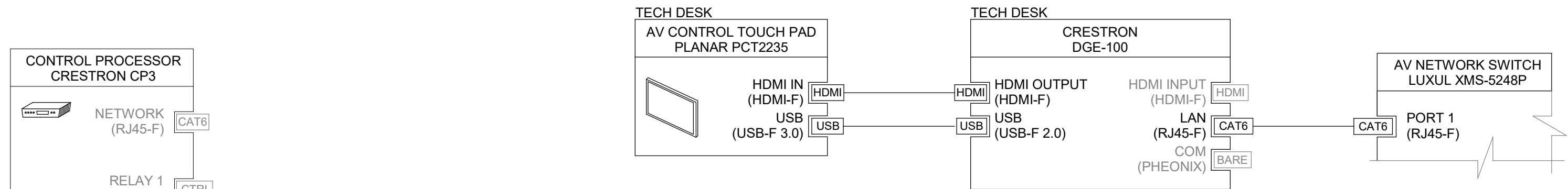

① AV301 - VIDEO SIGNAL FLOW DIAGRAM - SKETCH  
NOT TO SCALE

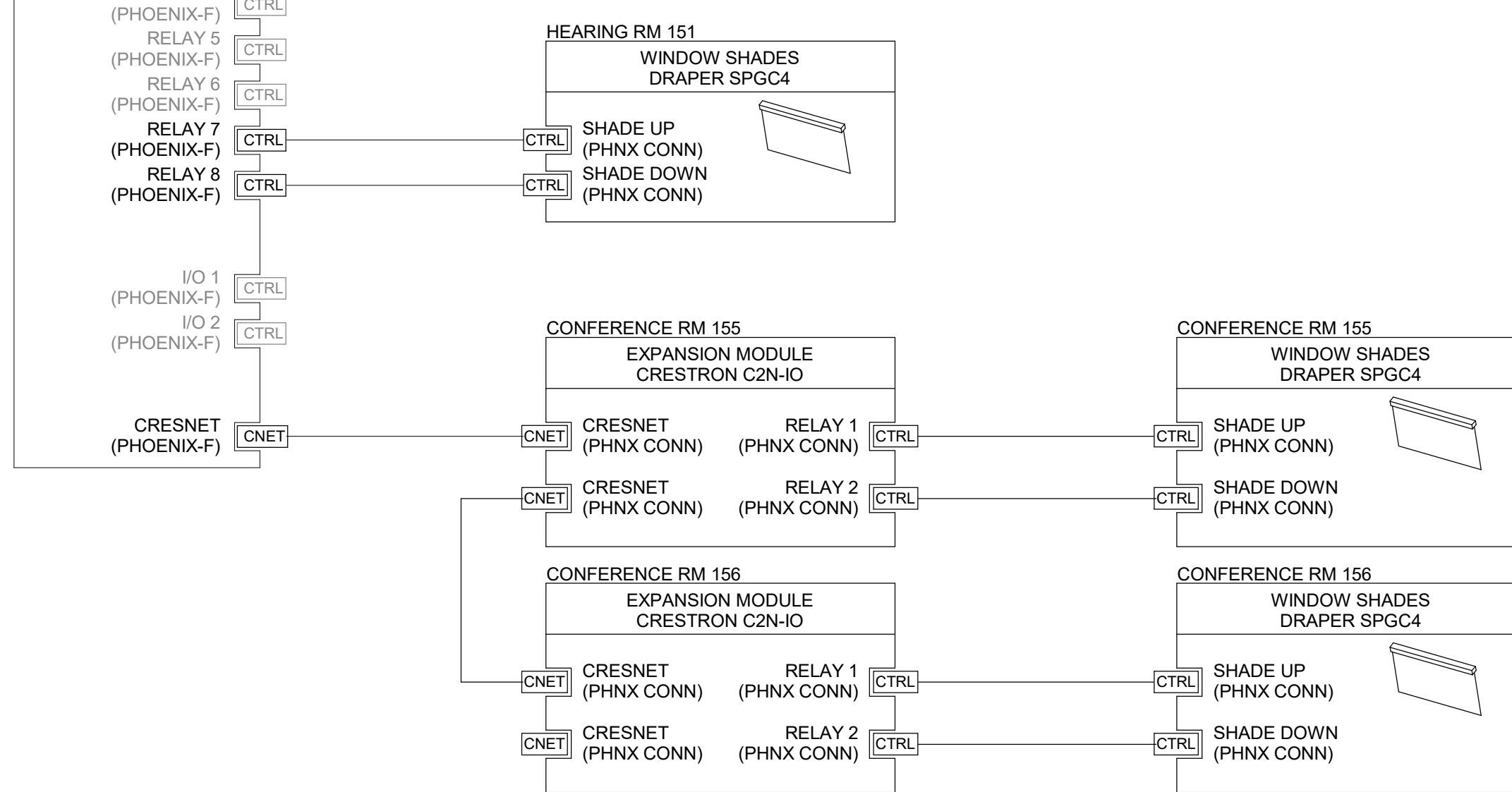

② AV303 - CONTROL FLOW DIAGRAM - SKETCH  
NOT TO SCALE

## BIDDER QUESTIONS

### **IUB HEARING ROOM REMODEL** DAS PROJECT NO. 9027.00

The information below is provided for clarification purposes only. The information contained in these questions and answers does NOT modify, supplement or replace information contained in the Project Manual and on the Drawings and is NOT part of the Contract Documents.

1. Do the existing floor ducts have a continuous cover to allow access from the new floor boxes to the existing floor duct?

*The existing electrical floor duct is not a "trench" style continuously accessible system. It is only accessible via junction boxes, one of which is located near the new floor boxes in the hearing room.*

2. Do you want install and training cost included in BP2 base bid?

Yes.

3. Does BP1 need to put in a bid for BP2 or BP2 related alternates?

*Not required, but would be acceptable.*

4. Which Alternates does BP1 or BP2 need to respond to?

*BP1 to respond to BP1 Base Bid, Alternate 3, 4, 5. BP2 to respond to BP2 Base Bid, Alternate 1, 2, and 4*



Ryan Companies  
 14001 University Ave Suite 300  
 Clive, Iowa 50325  
 Phone: (515) 309-8500  
 Fax: (515) 309-8550

## 9027 IUB Hearing Room Remodel - Pre Bid Meeting Minutes

**MEETING DATE:** 09/26/2018

**MEETING TIME:** 11:00 AM - 12:00 PM

**MEETING LOCATION:** Iowa Utilities Board - 1375 E Court Ave, Des Moines, IA 50319

**OVERVIEW:**

Pre-bid meeting is to review project scope of work, bid proposal requirements, site logistics and walk the site to review existing conditions.

**NOTES:**

**ATTACHMENTS:**

[180926\\_Attendance.pdf](#)

### Project Team

No	Title	Assignment	Due Date	Priority	Status
1.1	Project Teams				Open
<p><b>Description:</b>            IUB - Owner</p> <ul style="list-style-type: none"> <li>• Geri Huser; Utility Board Chair</li> <li>• Richard Lozier; Utility Board Member</li> <li>• Nick Wagner; Utility Board Member</li> </ul> <p>DAS - Owner Representative</p> <ul style="list-style-type: none"> <li>• Josh Herman; 515-725-1293; <a href="mailto:josh.herman@iowa.gov">josh.herman@iowa.gov</a></li> </ul> <p>Ryan Companies - CM</p> <ul style="list-style-type: none"> <li>• Sr. PE - Derek Stickfort; 515-412-5526; 515-231-7730; <a href="mailto:derek.stickfort@ryancompanies.com">derek.stickfort@ryancompanies.com</a></li> </ul> <p>BNIM - Designer</p> <ul style="list-style-type: none"> <li>• Kayla Berkson; 515-559-0431; <a href="mailto:kberkson@bnim.com">kberkson@bnim.com</a></li> <li>• Carey Nagle;</li> </ul> <p>KCL - Designer Consultant (MEP/AV)</p> <ul style="list-style-type: none"> <li>• James Deeds; 515-371-9970; <a href="mailto:jdeeds@kclengineering.com">jdeeds@kclengineering.com</a></li> </ul>					

### Project Scope/Schedule

No	Title	Assignment	Due Date	Priority	Status
2.1	BP #1 - Scope Highlights				Open
<p><b>Description:</b></p> <ol style="list-style-type: none"> <li>1. Select Demolition</li> <li>2. Removal/salvage of existing dark carpet tile for attic stock.</li> <li>3. Removal/reinstall Northeast door/frame/hardware and access control devices.</li> </ol>					

These meeting minutes are believed to be an accurate reflection of those items discussed and the conclusions that were reached during the referenced meeting.

Please contact Ryan Companies if there are any discrepancies or questions with the content of these minutes.

4. Refurbishing of Aluminum window frame and sill and precast patching repair.
5. New Millwork, stainless steel handrails, carpet tile and resilient base.
6. Patch and paint.
7. Electrical, communication, security, and AV wiring demolition.
10. New can lights and wall wash fixtures above the Board desk.
11. Electrical ceiling- hung and wall mounted flat panel displays.
12. New power receptacles in new floor boxes and millwork.
13. New low voltage cabling for telecom and AV system.
14. Panic button relocation/addition.
15. Protection of existing finishes/materials - wood wall and ceiling panels, acoustical ceiling panels, and windows.

**Official Documented Meeting Minutes:**

BP 1 does not need to include bid numbers for BP 2 or BP 2 related alternates, but may do so.

2.2	BP #2 - Scope Highlights				Open
-----	--------------------------	--	--	--	------

**Description:**

1. Demolition of existing AV system components. Equipment will be owner salvage.
2. Install/setup audio-visual system.
3. Lease term: 60 months.
4. Lease expiration or termination: lessor shall disconnect and remove equipment from lessee's premises.
5. Option to purchase: lessee may purchase the system at a mutually agreed fair market value as determined at end of lease.
6. See 'General Terms and Conditions for Service Contracts/Solicitations'
7. Lease Terms and Conditions Proposal - submitted with Bid Form.

**Official Documented Meeting Minutes:**

BP 2 to include the cost of installation and training in the monthly Base Bid cost.

Concerning the submitted lease proposal: The State's Procurement office will continue to work with selected AV Contractor to finalize the Final Lease terms.

CM and Design team to further clarify whose scope cabling is in. See addendum when issued for further guidance.

2.3	Construction Schedule				Open
-----	-----------------------	--	--	--	------

**Description:**

- Owner-Trade Contractor 802 contract executed by 10/26/18
- Anticipated Procurement of materials 10/26/18 to 1/9/19
- Anticipated Construction start 1/10/19.
- See example schedule from Bid Documents.
- BP1 and BP2 Substantial Completion by 3/11/19.

## Bidding

No	Title	Assignment	Due Date	Priority	Status
3.1	Bid Submission Requirements				Open

**Description:**

- Questions, clarifications, substitutions submit to [steve.oberbroeckling@iowa.gov](mailto:steve.oberbroeckling@iowa.gov) by 10/3/18.
- Review Instruction to Bidders Spec Section 002113, specifically 3.01 requirements.
  - Requires bid form, non-discrimination clause, Targeted Small Business, and Bid security/bond (sample forms included in Bid Documents)
  - Can email bid only if less than/equal to \$135,000, deliver in person if over that amount
  - Electronic bid submission submit to [steve.oberbroeckling@iowa.gov](mailto:steve.oberbroeckling@iowa.gov) - Include RFB# in title.
  - Review Bid Submittal Checklist Spec Section 00 4393
  - Bid Package #2 - AV: Bid includes lease, must provide proposal with Bid Form.
- Bid form
  - Acknowledge any addendum; at least one will be issued with this meeting report and attendees
  - Fill in all alternates.
- Look at DAS Purchasing website document for addendum or any additional information

These meeting minutes are believed to be an accurate reflection of those items discussed and the conclusions that were reached during the referenced meeting.

Please contact Ryan Companies if there are any discrepancies or questions with the content of these minutes.

- Obtain plans and specifications from Beeline and Blue Des Moines 515-244-1611

3.2	Key Notes for DAS Jobs				Open
<p><b>Description:</b></p> <ul style="list-style-type: none"> <li>• Performance and Payment Bonds will be required, along with certificate of insurance prior to execution of any contract.</li> <li>• Submit a subcontractor list within 48 hours of bid package award, see section 00 2113.</li> <li>• Project is TAX EXEMPT - DAS will issue certificates. CM will send a form to awarded Contractor to fill out.</li> <li>• Background checks will be required, see section 01 3100.</li> <li>• Any added circuits will require an electrical permit with State Fire Marshall Office - Electrical Bureau (NOT City of DSM).</li> <li>• EADOC Project Management Software - Free to Contractor             <ul style="list-style-type: none"> <li>◦ Contracts, RFIs, ASIs, Submittals all in EADOC.</li> </ul> </li> </ul>					

**Official Documented Meeting Minutes:**

There is an example of the Performance and Payment bonds in the Project Manual.

Certificate of Insurance: Contractors insurance should reflect similar to example provided in the Project Manual.

3.3	Key Bid Dates				Open
<p><b>Description:</b></p> <ul style="list-style-type: none"> <li>• Questions or substitutions via email to Steve Oberbroeckling due Wed 10/3/18 at 2:00 PM</li> <li>• Issue addendum to bidders issue by Mon 10/8/18</li> <li>• Bids due Thurs 10/11/18 at 2:00 PM</li> <li>• Eval bids, recommend award, issue Notice of Intent (NOI) issue Tue 10/17/18</li> </ul>					

## Site Logistics, Temporary Facilities, Expectations

No	Title	Assignment	Due Date	Priority	Status
4.1	Site Logistics and Temporary Facilities				Open
<p><b>Description:</b></p> <ul style="list-style-type: none"> <li>• Review Temporary Facilities spec section 01 5000.</li> <li>• Must allow for continued IUB operations.</li> <li>• Approved use of on site restrooms.</li> <li>• Material removal/delivery via East entry to building.</li> <li>• Dumpster Location - On east drive of building.</li> <li>• Parking Location - Lot 3.</li> </ul>					

## Site Tour

No	Title	Assignment	Due Date	Priority	Status
5.1	Review Existing Conditions				Open
<p><b>Description:</b> Review Hearing Room and adjacent conference rooms.</p>					

**ATTENDEES:**

Name	Company	Phone Number	Email	Attendance

These meeting minutes are believed to be an accurate reflection of those items discussed and the conclusions that were reached during the referenced meeting.

Please contact Ryan Companies if there are any discrepancies or questions with the content of these minutes.



IUB Pre Bid Meeting Sign-in Sheet – 9/26/18  
 Hearing Room Remodel – Des Moines, IA  
 DAS Job# 9027.00

Name	Company	Phone	Email
DEREK STICKFORT	RYAN COMPANIES	515-231-7720	DEREK.STICKFORT@RYANCOMPANIES.COM
Jane Eppink	Apex	515-779-3333	jeppink@apexsiowa.com
Mike Henson	Apex	515-720-5096	mihenson@apexsiowa.com
Tina Wright	Conference Technologies	515-280-9800	twright@conference.tech.com
Tim Johnston	OLP CONSTRUCTION	515-877-9391	Tim.JohnstonOLP@OUTLOOK.COM
Lenore Hamill	EMBARKIT	515-440-4511	lenore@embarkit.com
Gerson Carrillo	"	"	gerson@embarkit.com
Heath Moore	C&C	515-289-3707	hmoore@cecinfo.com
Ed Riba	C&C	816-682-5624	eriba@cecinfo.com
Austin Horner	BALL TEAM	515-499-0339	ahorner@buildwithball.com
JAMES DEEDS	KCL	515-371-9970	jdeeds@kelengineering.com
Brandon Chandler	KCL	515-494-6272	BChandler@kelengineering.com
KAYLA BERKSON	BNIM	515-974-6462	kberkson@bnim.com
Josh Herman	DAS	515-201-2197	josh.herman@iowa.gov