

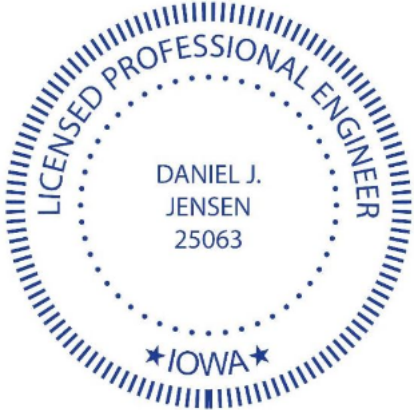

CONSTRUCTION SPECIFICATIONS

FOR

GUT813130A BREAKPOINT WETLAND
GUTHRIE COUNTY, IOWA

June 2023

	I hereby certify that this engineering document was prepared by me or under my direct personal supervision and that I am a duly licensed Professional Engineer under the laws of the State of Iowa.	
		06/06/2023
	Signature	Date
	Printed or typed name	<u>Daniel Jensen</u>
	License Number	<u>25063</u>
My License Renewal Date is: <u>December 31, 2023</u>		
Pages, Sheets, or Divisions covered by this Seal: All		

PREPARED BY:

SHIVEHATTERY
ARCHITECTURE+ENGINEERING

PROJECT #4213850



NATURAL RESOURCES CONSERVATION SERVICE CONSTRUCTION SPECIFICATIONS

For

GUT813130A BREAKPOINT WETLAND

Guthrie County, Iowa

List of Specifications

<u>Specification Number</u>	<u>Title</u>	<u>Pages</u>
IA-1	SITE PREPARATION	2
IA-3	STRUCTURE REMOVAL	2
IA CS-005	POLLUTION CONTROL	3
IA-6	SEEDING AND MULCHING FOR PROTECTIVE COVER	4
CS-08	MOBILIZATION	3
IA-9	SUBSURFACE DRAIN INVESTIGATION, REMOVAL, AND REPAIR	4
IA-11	REMOVAL OF WATER	2
IA-13	SHEET PILING	3
IA-21	EXCAVATION	2
IA-23	EARTHFILL	4
IA-26	TOPSOILING	2
IA-31	CONCRETE	6
IA-46	TILE DRAINS FOR LAND DRAINAGE	5
IA-51	CORRUGATED METAL PIPE CONDUITS	5
IA-61	LOOSE ROCK RIPRAP	2
IA-62	CONCRETE GROUT FOR RIPRAP	3
IA-81	METAL FABRICATION AND INSTALLATION	2
IA-92	FENCES	23
IA-95	GEOTEXTILE	5

These specifications are part of the construction plans. The work shall be performed in accordance with the drawings and specifications unless otherwise approved, in writing, by NRCS. For items of work requiring NRCS inspection, it is the responsibility of the contractor to keep the local NRCS office informed of the progress of work so that timely inspections may be performed. Work installed without NRCS inspection will not be certified as meeting NRCS standards.



Construction Specification 000 IA CS-00-1 Site Preparation

1. SCOPE

Site preparation work shall consist of clearing, grubbing, stripping, refuse removal, bank sloping and structure removal on the site as necessary to rid the site of all undesirable materials on or near the surface and prepare the site for the structure. All woody growth within the construction area shall be cleared and all stumps and roots one inch in diameter or larger shall be grubbed from the site. In addition, all areas within 25 feet of the footprint of the structure shall be cleared and grubbed except as directed by NRCS. The work shall also consist of the removal and disposal of structures (including fences) that must be removed to perform other items of work.

For wetland restoration, enhancement, or creation projects, the wetland area shall be disturbed as little as possible and existing naturally vegetated spillway areas shall not be disturbed.

2. FOUNDATION PREPARATION

The construction areas shall be stripped a minimum of 6 inches to remove all unsuitable materials such as organic matter, grasses, weeds, sod, debris, and stones larger than 6 inches in diameter.

In an earth embankment foundation area, all channel banks and sharp breaks shall be sloped to no steeper than 1.5 horizontal to 1 vertical.

The foundation area shall be thoroughly scarified before placement of fill material. The surface shall have moisture added or shall be compacted if necessary so that the first layer of fill material can be compacted and bonded to the foundation.

3. STRIPPED MATERIAL DISPOSAL

Suitable soil material shall be stockpiled for use as topsoil. The other stripped materials shall be buried, removed from the site, or disposed of as directed by the owner or NRCS. Whenever possible, material shall not be disposed of in the pool area created by the structure.

Stockpiled materials around a construction site should be placed so as not to hinder subsequent construction operations.

4. DISPOSAL OF REFUSE MATERIALS

Waste materials from clearing and structure removal shall be burned or buried at locations approved by the owner. Buried materials shall be covered with a minimum of 2 feet of earthfill. Whenever possible, material shall not be disposed of in any pool area created by the structure.

All refuse shall be disposed of in a manner which complies with all local and state regulations.

5. SALVAGE

Items to be salvaged shall be as shown on the drawings. Structures and fencing materials that are designated to be salvaged shall be carefully removed and neatly placed in the specified storage areas.

6. SPECIFIC SITE REQUIREMENTS

A. Measurement and Payment

Compensation for any work item described in the contract documents but not listed in the bid schedule will be included in the payment for the item of work to which it is made subsidiary. Such items and bid items to which they are made subsidiary are identified in Items of Work and Construction Details section of this specification.

For items of work which lump sum prices are established in the contract, the quantity of work will not be measured for payment. Payment for each item will be made at the contract lump sum price and will constitute full compensation for completion of the work.

For items of work for which specific unit prices are established in the contract, the payment will be made based on the approved quantity measured by the engineer or weight tickets. Payment will constitute full compensation of the work completed as defined by each work item.

B. Items of Work and Construction Details

1. Bid Item No. 1 – Site Clearing, Preparation, and Waste Disposal

This item will consist of work to remove and dispose of existing material to remove vegetation on areas to be excavated or filled. Total depth of vegetative stripping and topsoil stripping shall equal a combined depth of 12", with the estimated cubic yards of top soil removal as shown in the plans. The topsoil replacement quantity shall be paid separately.

This item will also include any tree and brush removal along with any fences. These shall be considered incidental to site stripping.

This item will be paid out as a lump sum.

2. Bid item No. 22 – Crop Damage

This item consists of crop damage that results from construction activities. It is recommended contractor remove corn residue rather than knock it down.

Payment for crop damage will be made to the nearest 0.1 acre as measured by the Engineer or their representative. The unit rate for crop damage will be determined by the Division near the completion of construction and added to the contract with a Change Order. Payment will be made to contractor who will pay landowner.

**Construction Specification
000 IA-3 Structure Removal**

1. SCOPE

The work shall consist of the removal, salvage and/or disposal of structures (including fences) from the designated areas and as indicated on the drawings.

2. MARKING

Each structure or item to be removed will be marked by means of stakes, flags, painted markers or other suitable methods.

3. REMOVAL

All structures designated for removal shall be removed to the specified extent and depth.

4. SALVAGE

Structures that are designated to be salvaged shall be carefully removed and neatly placed in the specified storage areas. Salvaged structures that are capable of being disassembled shall be dismantled into individual members or sections. Such structures shall be neatly match marked with paint prior to disassembly. All pins, nuts, bolts, washers, plates and other loose parts shall be marked or tagged to indicate their proper location in the structure and shall be fastened to the appropriate structural member or packed in suitable containers. Materials from fences designated to be salvaged shall be placed outside the work area on the property from which they are removed. Wire shall be rolled into uniform rolls of convenient size. Posts and rails shall be neatly piled.

5. DISPOSAL OF REFUSE MATERIALS

Refuse materials resulting from structure removal shall be burned or buried at locations shown on the drawings. Buried materials shall be covered with a minimum of 2 feet of earthfill. Whenever possible, material shall not be disposed of in the pool area created by the structure.

All refuse shall be disposed of in a manner which complies with all local and state regulations.

Specific Site Requirements

A. Items of Work and Construction Details

1. Items of work to be performed in accordance with this specification and the construction details therefore are:
 - (a) Subsidiary Items, Fence Removal
 - (1) No separate payment will be made for removal of items as shown on the plans. Compensation for this item will be incidental to other items of work.
 - (2) This item is subsidiary to Bid Item 5.



**Construction Specification
000 000 IA CS-005 Pollution Control 2011**

1. SCOPE

The work shall consist of installing measures or performing work to control erosion and minimize the production of sediment and other pollutants to water and air during construction operations.

2. MATERIALS

All materials furnished shall meet the requirements shown on the drawings or in the specifications.

3. EROSION AND SEDIMENT CONTROL MEASURES AND WORKS

The measures and works shall include, but are not limited to, the following:

Staging of Earthwork Activities: The excavation and moving of soil materials shall be scheduled so that areas unprotected from erosion will be minimized. These areas will be unprotected for the shortest time feasible.

Seeding: Structures and disturbed areas shall be seeded as soon as possible after construction is completed.

Temporary seedings may be used as an alternative to other stabilization measures as approved by NRCS.

Mulching: Construction areas that have been disturbed but have no construction activity scheduled for 21 days or more shall have erosion protection measures applied by the 14th day. This erosion protection may be mulching or other approved temporary measures. Construction areas shall not be left open during a winter shutdown period and shall be protected by mulching.

All seeding and mulching shall be completed in accordance with the seeding plan and Iowa Construction Specification IA-6, Seeding and Mulching for Protective Cover.

The following works may be temporary. If they are installed as a temporary measure, they shall be removed and the area restored to its original state when they are no longer needed or when permanent measures are installed.

Diversions: Diversions may be required to divert clean runoff water away from work areas and to collect runoff from work areas for treatment and safe disposition.

Stream Crossings: Culverts or bridges may be required where construction equipment must cross streams.

Sediment Basins: Sediment basins may be required to settle and filter out sediment from eroding areas to protect properties and streams below the construction site.

Sediment Filters: Straw bale filters, geotextile sediment fences, or other equivalent methods may be used to trap sediment from areas of limited runoff. Sediment filters shall be properly anchored to prevent erosion under them.

Waterways: Waterways may be required for the safe removal of runoff from fields, diversions, and other structures or measures.

4. CHEMICAL POLLUTION

The Contractor shall provide watertight tanks or barrels or construct a sump sealed with plastic sheets to be used to dispose of chemical pollutants, such as drained lubricating or transmission oils, greases, soaps, concrete mixer wash water, asphalt, etc., produced as a by-product of the construction work.

At the completion of the construction work, sumps shall be removed and the area restored without causing pollution.

Sanitary facilities such as chemical toilets or septic tanks shall not be placed adjacent to live streams, wells, or springs. They shall be located at a distance sufficient to prevent contamination of any water sources. At the completion of construction work, facilities shall be disposed of without causing pollution.

5. AIR POLLUTION

The burning of brush or trash or disposal of other materials shall adhere to local and state regulations.

Fire prevention measures shall be taken to prevent the start or the spreading of wild fires, which result from project work. Fire breaks or guards shall be constructed at locations shown on the drawings.

All public access or haul roads used by the contractor during construction of the project shall be sprinkled or otherwise treated to fully suppress dust. All dust control methods shall insure safe operations at all times. If chemical dust suppressants are used, the material shall be a commercially available product specifically designed for dust suppression and the application shall follow manufacturer's requirements and recommendations. A copy of the product data sheet and manufacturer's recommended application procedures shall be provided to the Engineer five working days before use.

6. MAINTENANCE, REMOVAL, AND RESTORATION

All pollution control measures and works shall be adequately maintained in a functional condition as long as needed during the construction operation. All temporary measures shall be removed and the site restored to as near original conditions as practical.

Specific Site Requirements

A. Measurement and Payment

1. Compensation for any work item described in the contract documents but not listed in the bid schedule will be included in the payment for the item of work to which it is made subsidiary. Such items and bid items to which they are made subsidiary are identified in the Items of Work and Construction Details section of the Special Specification. For any item described in the bid documents, not included in any bid item, or not made subsidiary to any bid item in the Items of Work, shall be made subsidiary to the Mobilization bid item.
2. Quantities used for progress payments shall be considered as only approximate and provisional and shall be subject to recalculation, adjustment, and correction by the engineer in subsequent payment applications. Inclusion of any quantities in a progress payment, or failure to disapprove the work at the time of any progress payment, shall not be construed as acceptance of the corresponding work or materials.
3. For items of work which lump sum prices are established in the contract, the quantity of work will not be measured for payment. Payment for each item will be made at the contract lump sum prices and will constitute full compensation for completion of the work.

B. Items of Work and Construction Details

1. Items of work to be performed in conformance with the specification and the construction details therefore are:
 - a. Subsidiary Item, Sediment Filters
 - (1) This item consists of all work to install, maintain, and remove sediment filters for the project. Sediment filters to be removed once vegetation is established.
 - (2) No separate payment will be made for sediment filters. Compensation for this item will be incidental to other items of work.
 - (3) Contractor shall perform all construction activities in a manner that will minimize water pollution, air pollution, and soil erosion. Sediment filters shall be placed as needed where off-site erosion could occur or as directed by the engineer.
 - (4) Contractor is responsible to limit discharge of sediment off site.
 - (5) Sediment filters are subsidiary to Bid item 5.
 - b. Subsidiary Item, Pollution Control
 - (1) This item will consist of performing all construction activities in a manner that will minimize water pollution, air pollution and soil erosion.
 - (2) Contractor shall comply with all local and federal laws.
 - (3) No separate payment will be made for Pollution Control. Compensation for this item will be incidental to other items of work.
 - (4) Pollution Control is subsidiary to Bid item 5.

Construction Specification 000 IA-6 Seeding and Mulching for Protective Cover

1. SCOPE

The work shall consist of seeding, mulching, and fertilizing all disturbed areas and other areas as indicated on the drawings or otherwise designated.

2. SEEDBED PREPARATION AND APPLICATION

The entire area to be seeded shall be reasonably smooth and all washes and gullies shall be filled to conform to the desired cross-section before actual seedbed preparation is begun. At this stage of the operation, the required fertilizer and lime shall be applied uniformly and incorporated into the top 3 inches of the soil with suitable tillage equipment. The seedbed preparation operation shall be suspended when the soil is too wet or too dry. The seedbed shall be loosened to a depth of at least three inches.

On side slopes steeper than 2-1/2 horizontal to 1 vertical, the 3 inch minimum depth of seedbed preparation is not required, but the soil shall be worked enough to insure sufficient loose soil to provide adequate seed cover.

Unless otherwise specified, the seeding operation shall be performed immediately after preparation of the seedbed. The seed shall be drilled or broadcast by equipment that will insure uniform distribution of the seed.

3. MATERIALS

The seeding, fertilizing, and mulching requirements are as specified on Form IA-CPA-4.

Straw from cereal grains or hay will be used as mulching material. It shall be relatively free of weeds.

4. MULCH APPLICATION

The required mulching shall be performed as soon as possible after seeding unless otherwise specified. The mulch shall be applied uniformly over the area. The type and rate shall be as specified. When mulching is required, all areas seeded during any one day shall be mulched within 24 hours. The mulch may be spread by any means that results in a uniform cover.

The mulch shall be anchored. Anchoring of the mulch may be performed by a mulch anchoring tool or regular farm disk weighted and set nearly straight, by installation of mulch netting, or by other methods approved by NRCS.

5. SPECIFIC SITE REQUIREMENTS

A. Measurement and Payment

Compensation for any work item described in the contract documents but not listed in the bid schedule will be included in the payment for the item of work to which it is made subsidiary. Such items and bid items to which they are made subsidiary are identified in Items of Work and Construction Details section of this specification.

For items of work which lump sum prices are established in the contract, the quantity of work will not be measured for payment. Payment for each item will be made at the contract lump sum price and will constitute full compensation for completion of the work.

For items of work for which specific unit prices are established in the contract, the payment will be made based on the approved quantity measured by the engineer or weight tickets. Payment will constitute full compensation of the work completed as defined by each work item.

B. Items of Work and Construction Details

1. Bid Item No. 4 – Structure Seeding

This item will consist of seeding the dike except the upstream side slope below the weir elevation, auxiliary spillway, the tile outlet channel side slopes and any other disturbed areas noted on the plans or as determined by engineer.

All seed must be clean and weed free. Seeding rates are expressed in bulk pounds per acre. Seed quality shall not drop below 70% Pure Live Seed (PLS) where PLS = (percent germination plus percent dormant seed) times percent purity.

Seeding rates are as follows:

Smooth Brome grass 25 pounds/acre

Seed shall be applied with a drill and placed at ¼ to ½ inch deep.

Fertilizer shall be applied on the entire seeding area at the following rate:

Nitrogen (N) 30 pound/acre
Phosphorus (P₂O₅) 30 pounds/acre
Potassium (K₂O) 40 pounds/acre

Straw mulch shall be applied at a rate of 2 tons per acre on all areas receiving structure and channel seeding.

Seeding shall be completed during the following seeding periods:

Spring March 1 to May 15
Summer August 1 to September 15
Fall November 15 to Freeze-up

If construction is completed during any other time of the year, the seeding shall be performed at the next seeding period.

If seeding is completed during the spring seeding period, a companion crop of oats shall be seeded at a rate of 1-1/2 bushels per acre.

Measurement will be based on the areas successfully seeded to the nearest 0.1 acre.

2. Bid Item No. 2 – Buffer Seeding

This item will consist of seeding the areas designated on the plans as buffer seeding and include borrow areas, disturbed areas not seeded as part of structural seeding, and other areas within the easement. Buffer seeding is not required in area below normal pool elevation established by the weir elevation.

Some areas of the site may have existing CRP vegetation or steep slopes with existing vegetation. Local NRCS personnel will determine if these areas will be included as part of the buffer seeding areas for this project or will be left as is. This may affect the bid quantity and Contractor will verify with Engineer the number of acres that will require buffer seeding.

All seed must be clean and weed free. Seeding rates are expressed in pounds of pure live seed per acre. All seed must be yellow-tagged Iowa ecotype unless approved otherwise by IDALS-DSCWQ.

Seeding mixture shall include a minimum of 5 native grasses and 10 native forbs. The mixture shall provide a minimum of 30 grass seeds per square foot and 10 forbs seeds per square foot. Number of seeds will be based on Iowa Conservation Practice 327 "Native Species for Wildlife". Contractor's proposed seed mix shall be submitted to Engineer and local NRCS office for approval at least 2 weeks before seed is to be applied.

Seeding shall be completed during the following seeding periods:

Spring	April 1 to June 30
Fall	November 15 to Freeze-up

The seed bed shall be properly prepared prior to seeding:

- (a) Any weed control measures shall be completed prior to seeding. If spraying is used, then a span of two weeks shall be allowed between spraying and seeding.
- (b) If the land was in soybeans, no additional tillage is required. If the land was in corn or other vegetation, areas to be seeded shall be disked to thoroughly loosen and pulverize the soil to a depth of 3 inches. This may require multiple passes of equipment. If the land was used for pasture and has a smooth surface, the preparation in non-disturbed areas to be seeded shall include mowing any vegetation taller than 12 inches and applying an appropriate herbicide at the labeled rates to emergent growth 2 to 4 weeks after mowing. After the vegetation has died, the area shall be disked thoroughly loosen and pulverize the soil depth of 3 inches. If emergent growth occurs prior to seeding, the areas shall receive a second application of herbicide. Seeding shall not occur until the existing vegetation has died (about 1 week).
- (c) If deeper disking is used at the site, a lighter disk or spring harrow shall be used to remove deep furrows.
- (d) After disking operations and prior to seed application, the seedbed shall be firmed with a cultipacker or similar piece of equipment.
- (e) No lime or fertilizer is to be applied.

Sow seed with contour using a grassland or rangeland drill set for the specified seeding rates. The drill shall be equipped with double coulter furrow openers. The drill shall be

subject to acceptance by Engineer. Overlap each successive seeding pass to ensure complete coverage.

Plant seed not more than 1/4 inch deep; some seed may be seen on the surface after seeding.

Broadcasting by centrifugal-type or hydroseeder broadcasters, or by hand shall be allowed in areas not accessible to drills or other equipment. Once broadcast, the seed must be covered with soil to a depth no greater than 1/4 inch by means of hand rakes or other approved methods.

Upon completion of the seeding operation, cultipack the seedbed to provide a positive seed-soil contact. If the drill seeder is equipped with an approved cultipacker or press wheels, separate operations shall not be necessary. The type of cultipacker/seeder to be used shall be subject to acceptance by Engineer.

No mulch shall be required.

Measurement will be based on the area successfully seeded and measured to the nearest 0.1 acre.

3. Bid Item No. 3 – Switch Grass Seeding

This item will consist of seeding the areas designated on the plans as switch grass seeding within the easement.

All seed must be cleaned and weed free. Seeding rates are expressed in bulk pounds per acre. Seed quality shall not drop below 70% Pure Life Seed (PLS) where PLS = (% germination + % dormant seed) times % purity.

Seeding rates are as follows:

Winter Cover- Switch Grass 10 lbs. / acre

Seed shall be applied with a drill and placed at ¼ inch deep.

Fertilizer shall be applied on the entire seeding area at the following rate.

Nitrogen 30 lbs. / acre

Phosphorus (P2O5) 30 lbs. / acre

Potassium (K2O) 40 lbs. / acre

Straw mulch shall be applied at the rate of 2 tons per acre on all seeded areas.

Seeding will be completed during the following seeding periods:

Spring March 1 to May 15

Summer August 1 to September 15

Fall November 15 to freeze-up

If construction is completed during any other time of the year, the seeding shall be performed at the next seeding period.

If seeding is completed during the spring or summer seeding period, a companion crop of oats shall be seeded at a rate of one and one-half bushels per acre. If seeding is completed during the fall seeding period a companion crop of winter wheat shall be seeded at 30lbs/ac.

Measurement and payment will be based on the area successfully seeded calculated to the nearest one-tenth acre

4. Weed Control (Not a Bid item)

Weed control may be needed in portions of this site depending upon the start date of the contract, the initiation of grading, and the seeding dates.

Weed control will be added to the contract with a change order to be negotiated between Contractor and Division based on conditions observed and the type of weed control used and will be paid only once. If delays require additional weed control, this will be paid for at Contractor's own expense.

Weed control may include placement of a cover crop such as oats or rye, spraying with appropriate chemicals, or disking. If thistles are present, only spraying is allowed for weed control and shall include appropriate chemicals designed to control thistles.

**NATURAL RESOURCES CONSERVATION SERVICE
CONSTRUCTION SPECIFICATION**

Construction Specification 8—Mobilization and Demobilization

1. SCOPE

The work consists of the mobilization and demobilization of the contractor's forces and equipment necessary for performing the work required under the contract. It does not include mobilization and demobilization for specific items of work for which payment is provided elsewhere in the contract. Mobilization will not be considered as work in fulfilling the contract requirements for commencement of work.

2. EQUIPMENT AND MATERIAL

Mobilization shall include all activities and associated costs for transportation of contractor's personnel, equipment, and operating supplies to the site; establishment of offices, buildings, and other necessary general facilities for the contractor's operations at the site; premiums paid for performance and payment bonds including coinsurance and reinsurance agreements as applicable; and other items specified in section 4 of this specification.

Demobilization shall include all activities and costs for transportation of personnel, equipment, and supplies not required or included in the contract from the site; including the disassembly, removal, and site cleanup of offices, buildings, and other facilities assembled on the site specifically for this contract.

This work includes mobilization and demobilization required by the contract at the time of award. If additional mobilization and demobilization activities and costs are required during the performance of the contract as a result of changed, deleted, or added items of work for which the contractor is entitled to an adjustment in contract price, compensation for such costs will be included in the price adjustment for the item or items of work changed or added.

3. PAYMENT

Payment will be made as the work proceeds, after presentation of paid invoices or documentation of direct costs by the contractor showing specific mobilization and demobilization costs and supporting evidence of the charges of suppliers, subcontractors, and others. When the total of such payments is less than the lump sum contract price, the balance remaining will be included in the final contract payment. Payment of the lump sum contract price for mobilization and demobilization will constitute full compensation for completion of the work.

Payment will not be made under this item for the purchase costs of materials having a residual value, the purchase costs of materials to be incorporated in the project, or the purchase costs of operating supplies.

4. ITEMS OF WORK AND CONSTRUCTION DETAILS

A. Measurement and Payment

Compensation for any work item described in the contract documents but not listed in the bid schedule will be included in the payment for the item of work to which it is made subsidiary. Such items and bid items to which they are made subsidiary are identified in Items of Work and Construction Details section of this specification.

For items of work which lump sum prices are established in the contract, the quantity of work will not be measured for payment. Payment for each item will be made at the contract lump sum price and will constitute full compensation for completion of the work.

For items of work for which specific unit prices are established in the contract, the payment will be made based on the approved quantity measured by the engineer or weight tickets. Payment will constitute full compensation of the work completed as defined by each work item.

B. Items of Work and Construction Details

1. Bid Item No. 5 - Mobilization/Demobilization

This item shall consist of mobilizing and demobilizing personnel and equipment in preparation to perform the work within the scope of this contract.

Any work that is necessary to provide access to the site including, but not limited to, grading, temporary culverts, and clearing will be included in this item. When construction is completed access areas will be restored, as close as practical, to its original condition.

Any fence removed for access and /or to provide work area shall be replaced with same or like materials as approved by the engineer.

The Contractor shall exercise caution to minimize the amount of damage caused by the grading and clearing operations.

Portable toilets shall be provided at the construction site and used for the sanitary facilities.

This item shall not include transportation of personnel, equipment and operating supplies within the work limits areas of this contract.

Payment will constitute full compensation for related subsidiary item, Pollution Control.

Payment will be made as the work proceeds and will be paid out on the percent of the project complete as the work progresses. Payment of the

lump sum contract price for mobilization and demobilization will constitute full compensation for the completion of the work.

Payment will not be made under this item for the purchase costs of materials having a residual value, the cost of materials to be incorporated in the project, or the purchase costs of operating supplies.

Contractor is to contact "Iowa One Call" for utility locations a minimum of two (2) days prior to any excavation/construction. The ticket number must be provided to Engineer.

2. **Subsidiary Item – Sign Installation**

This item shall include all labor, materials, equipment and Iowa One Call notifications to install sign provided by Iowa Department of Agriculture and Land Stewardship, as shown on the plans or on next page.

This item is subsidiary to bid item 5.

NATURAL RESOURCES CONSERVATION SERVICE CONSTRUCTION SPECIFICATION

IA-9 SUBSURFACE DRAIN INVESTIGATION, REMOVAL, AND REPAIR

1. SCOPE

The work shall consist of investigation, location, repair, and/or removal of subsurface drains (tile) near new or existing animal waste storage facilities or in wetland restoration, enhancement, or creation project areas, or other situations where subsurface drains may be present.

2. INVESTIGATION AND LOCATION

An inspection trench at least 10 inches wide shall be dug at the location shown on the drawings or as directed by the engineer or his representative. The trench shall be at least 6 feet deep measured from the original ground line, unless otherwise shown on the plans. The Engineer or his representative shall examine the trench and excavated material to identify tile lines.

Size, material, operating condition and direction of flow of each conduit shall be documented. Location and flow line elevation of each conduit shall be surveyed with horizontal and vertical control based on benchmarks shown on the plans.

The inspection trench shall be documented by surveying the natural ground and trench bottom location and elevations at the beginning, end, and every 50 feet for trenches longer than 50 feet.

Backfilling shall not be started without approval of the Engineer. See Section 5 for backfill specifications.

Trench shields, shoring and bracing, or other methods necessary to safeguard the workers and work, and to prevent damage to the existing improvements shall be furnished, placed, and subsequently removed by the contractor.

3. TILE REPAIR

Unless designated for removal, replace damaged conduit with new conduit having equal or greater capacity using material specified in Section 6 or 7. When replacing short sections of clay or concrete tile with single-wall corrugated polyethylene pipe, use the next larger nominal size.

Make connections with manufactured fittings and tight joints. Where joints have gaps that would allow soil to enter, cover the joint with a permanent type material such as coal tar pitch treated roofing paper, fiber glass sheet or mat, or plastic sheet.

If the investigation trench has been excavated below the existing drain grade, backfill the trench with gravel or well-pulverized soil in layers not over four (4) inches thick and tamp by hand or manually directed power tamper to provide a firm foundation for the conduit at the existing grade. Do not backfill with any soil containing broken tile fragments.

Using selected soil free of hard clods, rocks, or frozen soil, hand tamp the backfill material around the haunch of the pipe in layers not over four (4) inches thick to provide support. Hold the conduit in place

mechanically while placing excavated material around and over the conduit to ensure proper alignment and grade is maintained. Complete the backfill operation according to Section 5.

4. TILE REMOVAL

Remove conduits as shown on the plans or directed by the Engineer or his representative, including envelope filter material or other flow enhancing material when present.

Cap or plug the open ends of the disconnected conduit to prevent soil entry when the conduit will continue to function downstream, or otherwise shown on the plans. For a minimum distance of two feet around each sealed conduit end, backfill in layers not over four (4) inches thick and tamp by hand or manually directed power tamper to a density equal to or greater than the surrounding undisturbed soil. Do not backfill with any soil containing broken tile fragments, large stones, frozen material, or large dry clods.

Where tile are located beneath an existing animal waste facility, remove the tile or fill the entire length of tile with concrete or Portland cement grout as shown on the plans. When tile removal is specified, the owner shall contact the Iowa Department of Natural Resources (IDNR) for permission to remove the drainage tile under the structure. The structure shall be emptied of waste or lowered to a point below the tile prior to its removal. The structure must be retested for percolation and the results submitted to IDNR and approval received prior to reusing the structure.

If shown on the plans or directed by the engineer, reroute upstream drain lines so the capacity of the upstream drainage system is maintained. Install conduit in accordance with Iowa Construction Specification IA-46, Tile Drains for Land Drainage.

5. BACKFILL

Compact soil around disturbed tile as specified in Section 3 (Tile Repair) and Section 4 (Tile Removal). Keep the backfill within 5 feet of the conduit free from large stones, frozen material, and large dry clods. Unless otherwise shown on the plans, backfill the remainder of the trench as follows:

For trenches located under or near structures, backfill in 12-inch layers and compact each layer to a density equal to or greater than the surrounding undisturbed soil.

For other locations, backfill the remainder of each trench with the excavated soil material which shall extend above the ground surface and be well rounded over the trench.

6. MATERIALS

Unless otherwise shown on the plans, conduit and fittings used for repair shall conform to the specifications listed in Table 1. Perforated pipe shall have a water inlet area of at least 1 square inch per foot, provided by perforations spaced uniformly along the long axis of the pipe. The perforations shall be circular or slots. Circular perforations shall not exceed 3/16 inch in diameter. Slots shall not be more than 1/8 inch wide.

Table 1. Acceptable pipe for subsurface drain repair

Kind of Pipe[#]	Specification
Corrugated Polyethylene (PE) Pipe and Fittings, 3 to 6 inch	ASTM F 405
Corrugated Polyethylene (PE) Pipe and Fittings, 3 to 24 inch	ASTM F 667
Corrugated Profile Wall (Dual Wall) Polyethylene (PE) pipe, 2 to 60 inch	ASTM F 2648 [§]
Corrugated Profile Wall (Dual Wall) Polyethylene (PE) pipe, 12 to 60 inch	ASTM F 2306 [§]
Polyvinyl Chloride (PVC) Plastic Pipe, Schedules 40, 80 and 120	ASTM D 1785
PVC Pressure-Rated Pipe (SDR Series)	ASTM D 2241
Clay drain tile	ASTM C 4
Concrete drain tile	ASTM C 412

[#]Pipe sizes are nominal and the ranges are inclusive

[§]Pipe conforming to AASHTO M 252 (3 to 10 inch), or AASHTO M 294 (12 to 60 inch) is acceptable.

7. SPECIFIC SITE REQUIREMENTS

A. Measurement and Payment

Compensation for any work item described in the contract documents but not listed in the bid schedule will be included in the payment for the item of work to which it is made subsidiary. Such items and bid items to which they are made subsidiary are identified in Items of Work and Construction Details section of this specification.

For items of work which lump sum prices are established in the contract, the quantity of work will not be measured for payment. Payment for each item will be made at the contract lump sum price and will constitute full compensation for completion of the work.

For items of work for which specific unit prices are established in the contract, the payment will be made based on the approved quantity measured by the engineer or weight tickets. Payment will constitute full compensation of the work completed as defined by each work item.

B. Items of Work and Construction Details

1. Bid Item No. 6 - DRAIN TILE INVESTIGATION & REMOVAL

This item will consist of the excavation necessary to locate and remove all tile under the embankment and to locate and determine the tie-in locations for the tile locations shown on the plans. This item shall also include backfilling of the trenches.

This item does not include the additional excavation required to excavate the embankment core trench, if included in the project. Excavation of the core trench is covered under Specification IA-21, Excavation.

The extent of the tile investigation shall be as shown on the drawings. If extra work is required to locate additional tile not shown on the drawings, the Contractor can request additional compensation, but it must be first approved by the Division.

The investigation should reveal where the tile crosses the embankment footprint or where it is located if it does not cross the embankment footprint

Payment for Drainage Tile Investigation and removal shall be made as noted in the plans.

**Construction Specification
000 IA-11 Removal of Water**

1. SCOPE

The work shall consist of the removal of surface water and ground water as needed to perform the required construction in accordance with the plans and specifications.

2. DIVERTING SURFACE WATER

The Contractor shall build, maintain and operate all cofferdams, channels, diversions, flumes, sumps, and other temporary protective works needed to divert surface water away from the construction site while construction is in progress.

3. DEWATERING THE CONSTRUCTION SITE

Foundations, cutoff trenches, borrow areas and other parts of the construction site shall be dewatered as needed for proper execution of the construction work. The Contractor shall furnish, install, operate and maintain all works and equipment needed to perform the dewatering.

4. EROSION AND POLLUTION CONTROL

Removal of water from the construction site, including the borrow areas shall be accomplished in such a manner that erosion and the transmission of sediment and other pollutants are minimized.

5. REMOVAL OF TEMPORARY WORKS

After temporary works have served their purposes and before the Contractor leaves the site, they shall be removed.

Specific Site Requirements

A. Measurement and Payment

1. Compensation for any work item described in the contract documents but not listed in the bid schedule will be included in the payment for the item of work to which it is made subsidiary. Such items and bid items to which they are made subsidiary are identified in the Items of Work and Construction Details section of the Special Specification. For any item described in the bid documents, not included in any bid item, or not made subsidiary to any bid item in the Items of Work, shall be made subsidiary to the Mobilization bid item.

2. Quantities used for progress payments shall be considered as only approximate and provisional and shall be subject to recalculation, adjustment, and correction by the engineer in subsequent payment applications. Inclusion of any quantities in a progress payment, or failure to disapprove the work at the time of any progress payment, shall not be construed as acceptance of the corresponding work or materials.

B. Items of Work and Construction Details

1. Items of work to be performed in conformance with this specification and the construction details therefore are:
 - a. Subsidiary Item, Dewatering
 - (1) This item shall include all costs to divert, pump, dam or other means to dewater the site as needed to complete construction activities.
 - (2) No separate payment will be made for removal of water. Compensation for this item shall be made subsidiary to Bid Item 5.

**Construction Specification
000 IA-13 Sheet Piling**

1. SCOPE

The work shall consist of furnishing and driving the specified sheet piling at the location shown on the drawings.

2. MATERIALS

Sheet piling shall conform to the requirements of ASTM A328 (Steel Sheet Piling), A572 (High-Strength Low-Alloy Columbium-Vanadium Structural Steel), or A690 (High-Strength Low-Alloy steel H-Piles and Sheet Piling for Use in Marine Environments). The sheet piling provided shall meet the required cross-section, section modulus, thickness, and steel grade shown on the drawings. Fabrication of sheet piles from shorter lengths of pile stock is not permitted.

3. DRIVING SHEET PILE

The piling shall be driven in a manner so as to insure perfect interlocking throughout the entire length of each pile. The piles shall be held in proper alignment during driving by means of suitable temporary guide structures which shall be removed when they have served their purpose.

Piling shall be driven to the full depth shown on the drawings unless otherwise approved by the engineer.

4. CUTTING OFF PILES

The contractor shall cut the piling off at the specified elevations. Piling length shall be sufficient to permit removal of all materials damaged by driving.

5. DEFECTIVE PILING

Any piling damaged in driving, driven out of its proper location, driven below the specified cut off elevation, or inaccurately cut off shall be pulled and replaced or re-driven. Any piling ruptured in the interlock or otherwise damaged during driving shall be pulled and replaced.

Specific Site Requirements

A. Measurement and Payment

1. Compensation for any work item described in the contract documents but not listed in the bid schedule will be included in the payment for the item of work to which it is made subsidiary. Such items and bid items to which they are made subsidiary are identified in the Items of Work and Construction Details section of the Special Specification. For any item described in the bid documents, not included in any bid item, or not made subsidiary to any bid item in the Items of Work, shall be made subsidiary to the Mobilization bid item.
2. Quantities used for progress payments shall be considered as only approximate and provisional and shall be subject to recalculation, adjustment, and correction by the engineer in subsequent payment applications. Inclusion of any quantities in a progress payment, or failure to disapprove the work at the time of any progress payment, shall not be construed as acceptance of the corresponding work or materials.
3. For items of work which Unit Prices are established in the contract, the quantity of work will be measured, estimated, or based on plan quantity. The determination of quantities of work performed under the contract will be made by the Engineer with the assistance of the contractor and will be based on lines and grades shown on the plans and as given during the progress of work or as evidenced by approved tickets for weight or liquid measure or by measurements made or approved by the engineer. The contractor will be paid based on the actual quantity of work completed and accepted.

B. Items of Work and Construction Details

1. Items of work to be performed in conformance with this specification and the construction details therefore are:
 - a. Bid Item 10, SHEET PILE WEIR
 - (1) This item shall consist of furnishing and installing the steel sheet piling shown on the drawings. This item shall include steel channel, bolts, and field cutting the side slopes of the sheet piling to the specified slope shown on the drawings.
 - (2) The sheet piling will be installed starting from the center of the weir section and progressing away from centerline. Bends and deflections shall be made with prefabricated pieces specifically made for a location.
 - (3) Sheet piling shall have the minimum following requirements
 - a. Minimum section modulus of 14.36 cubic inch per foot of wall.
 - b. Minimum grade of steel shall be 50 ksi.
 - c. Minimum moment of inertia of 71.82 in⁴ per foot of wall.
 - d. Minimum thickness of 0.250”.
 - e. Meet ASTM A-572 GR50.
 - (4) All holes shall be field drilled. Torch, plasma cutting, or other methods resulting in imperfect holes will not be permitted.
 - (5) Payment will be based on actual square feet of sheet pile installed after trimming and will constitute full compensation for related subsidiary items such as tie-back anchors, structure excavation, backfill, and removal of water.
 - (6) Refer to IA-81 for fabrication and installation specifications.

- b. Subsidiary Item, Steel Channel, plate and Angle
 - (1) This item will consist of furnishing and installing the steel channel, angle, and plate pieces used to form the crest of the sheet pile weir (waler). Steel channel shall be A36 structural steel.
 - (2) Refer to IA-81 for fabrication and installation specifications
 - (3) No separate payment will be made for Steel Channel. Payment for this item will be considered subsidiary to Bid Item 10.

- c. Subsidiary Item, Bolts, Nuts, and Washers
 - (1) This item will consist of furnishing and installing the bolts, nuts and washers used to construct the sheet pile as shown on the plans.
 - (2) Bolts shall meet ASTM A307 Grade A.
 - (3) Washers shall meet ASTM F436.
 - (4) Nuts shall meet ASTM A563.
 - (5) Refer to IA-81 for fabrication and installation specifications
 - (6) No separate payment will be made for bolts, nuts, or washers. Payment for this item will be considered subsidiary to Bid Item 10.

**Construction Specification
000 IA-21 Excavation**

1. SCOPE

The work shall consist of the excavation required by the drawings and specifications and disposal of the excavated materials. The cutoff trench and any other required excavations shall be dug to the lines and grades shown on the drawings or as staked in the field. Structure or trench excavations will conform to all safety requirements of OSHA.

2. USE OF EXCAVATED MATERIALS

Suitable materials from the specified excavations shall be used in the construction of required permanent earth fill. The suitability of materials for specific purposes shall be determined by the NRCS Inspector.

3. DISPOSAL OF WASTE MATERIAL

All surplus or waste material shall be disposed of in areas shown on the drawings or as approved by the NRCS Inspector. The waste material shall be smoothed and sloped to provide drainage.

4. STRUCTURE AND TRENCH EXCAVATION

Structure or trench excavations will conform to all safety requirements of OSHA.

5. BORROW EXCAVATION

When the quantities of suitable materials obtained from specified excavations are insufficient to construct the specified fills, additional materials shall be obtained from the designated borrow areas as shown on the drawings or as approved by NRCS and the landowner. On wetland projects, borrow shall not be taken from the wetland area within 10 feet of the embankment or as shown on the drawings.

Borrow areas shall be excavated and grading completed in a manner to eliminate steep or unstable side slopes or hazardous or unsightly conditions.

6. OVER-EXCAVATION

Excavation beyond the specified lines and grades shall be corrected by filling the resulting voids with compacted earthfill, except that if the earth is to become the subgrade for riprap, sand or gravel bedding or drainfill, the voids shall be filled with material conforming to the specifications for the riprap, bedding or drainfill, as appropriate.

Specific Site Requirements

A. Measurement and Payment

1. Compensation for any work item described in the contract documents but not listed in the bid schedule will be included in the payment for the item of work to which it is made subsidiary. Such items and bid items to which they are made subsidiary are identified in the Items of Work and Construction Details section of the Special Specification. For any item described in the bid documents, not included in any bid item, or not made subsidiary to any bid item in the Items of Work, shall be made subsidiary to the Mobilization bid item.
2. Quantities used for progress payments shall be considered as only approximate and provisional and shall be subject to recalculation, adjustment, and correction by the engineer in subsequent payment applications. Inclusion of any quantities in a progress payment, or failure to disapprove the work at the time of any progress payment, shall not be construed as acceptance of the corresponding work or materials.
3. For items of work which Unit Prices are established in the contract, the quantity of work will be measured, estimated, or based on plan quantity. The determination of quantities of work performed under the contract will be made by the Engineer with the assistance of the contractor and will be based on lines and grades shown on the plans and as given during the progress of work or as evidenced by approved tickets for weight or liquid measure or by measurements made or approved by the engineer. The contractor will be paid based on the actual quantity of work completed and accepted.

B. Items of Work and Construction Details

1. Items of work to be performed in conformance with this specification and the construction details therefore are:
 - a. Bid Item 7, Overexcavation, Core Trench Undercut
 - a. This item will consist of excavating the core trench as shown in the plans and construction details. Payment will be made on the actual quantity completed and accepted. Core trench length may vary depending on the soils encountered. Core trench must terminate in suitable soils as determined by the Engineer.
 - b. Fill for the core trench shall be paid for on the actual quantity basis under Bid Item 8.
 - b. Subsidiary Item, Excavation for Earthfill and Structure Installation
 - a. This item will consist of the excavation of material in locations shown on the plans for use as Earthfill and as required for structure installation.
 - b. All excavation required for the project will be balanced onsite in areas designated as Earthfill. A shrinkage factor of 25% was used to estimate earthwork.
 - c. No separate payment will be made for excavation for earthfill and structure installation for those items requiring excavation including but not limited to Bid item 6, 8, 10, 13, 14, 15, 16, 17, 19, 20, & 21 to which excavation is made subsidiary.

**Construction Specification
000 IA-23 Earthfill**

1. SCOPE

The work shall consist of the construction of earth fills required by the drawings and specifications. The completed work shall conform to the lines, grades, and elevations shown on the drawings or as staked in the field.

2. MATERIALS

All fill materials shall be obtained from required excavations and designated borrow areas. Fill materials shall contain no sod, brush, roots or other bio-degradable materials. Rocks larger than 6 inches in diameter shall be removed prior to compaction of the fill.

3. FOUNDATION PREPARATION

Foundations for earthfill shall be stripped a minimum of 6 inches to remove vegetation and other unsuitable materials. Foundation surfaces shall be scarified to a minimum depth of 2 inches prior to placing fill material.

Foundation and abutment surfaces shall not be sloped steeper than 1.5 horizontal to 1 vertical unless otherwise shown on the drawings.

4. PLACEMENT

Fill shall not be placed until the required excavation and foundation preparation have been completed and the foundation has been inspected and approved by the Engineer. Fill shall not be placed upon a frozen surface, nor shall snow, ice, or frozen material be incorporated in the fill.

Adjacent to structures or pipes, fill shall be placed in a manner which will prevent damage. The height of the fill adjacent to structures or pipes shall be increased at approximately the same rate on all sides.

The materials used throughout the earth fill shall be essentially uniform. Selective placement shall be as shown on the drawings or approved by the Engineer.

If the surface of any layer becomes too hard and smooth for proper bond with the succeeding layer, it shall be scarified to a minimum depth of 2 inches before the next layer is placed.

The top surfaces of embankments shall be maintained approximately level during construction, except that a cross-slope of approximately 2% shall be maintained to ensure effective drainage.

When moving fill material from the borrow area(s) to the embankment by use of bulldozers only, the following steps shall be followed:

- Immediately after the borrow material is pushed to the embankment, it shall be spread in horizontal lifts placed parallel to the centerline of the embankment.
- Compactive effort will then be applied by operating equipment parallel to the centerline of the fill or embankment.
- Lift thicknesses shall be in strict compliance with Clause 6, below.

Sectional fills are not allowed unless they are shown on the construction drawings.

5. CONTROL OF MOISTURE CONTENT

The moisture content of the fill material shall be adequate for obtaining the required compaction. Material that is too wet shall be dried to meet this requirement, and material that is too dry shall have water added and mixed until the requirement is met.

The moisture content of the fill material shall be such that a ball formed with the hands does not crack or separate when struck sharply with a pencil and will easily ribbon out between the thumb and finger.

Earth foundations under and adjacent to concrete structures shall be prevented from drying and cracking before concrete and backfill are placed.

The application of water to the fill materials shall be accomplished at the borrow areas insofar as possible.

6. COMPACTION

Earth fill shall be compacted by one of the following methods as specified on the plans or in Section 8, Special Specifications. If no method is specified, compaction will be in accordance with Method 1.

- Method 1 - Earthfill shall be placed so that the wheels or tracks of the loaded hauling equipment, traveling in a direction parallel to the centerline of fill, pass over the entire surface of each layer being placed. Low ground pressure vehicles shall not be used for this purpose.
- Method 2 - Two (2) complete passes of a tamping-type roller will be made over each layer. The roller shall be capable of exerting a minimum force of two hundred (200) pounds per square inch.
- Method 3 - Minimum density shall be 90% of the maximum density as determined by ASTM D 698 and as shown on the plans.

The maximum thickness of a lift of fill before compaction shall be 9 inches, unless otherwise indicated on the drawings.

Fill adjacent to structures, pipe conduits, and appurtenances shall be placed in layers not more than 4 inches thick and compacted to a density equivalent to that of the surrounding fill. Methods used to obtain compaction for fine or coarse grained materials are as follows:

- For fine grained materials, hand tamping or manually directed power tampers may be used. Hand compaction only shall be used to compact the earthfill under the bottom half of circular pipes. Manually directed power tampers shall not be used in tight spaces where applying full compactive effort will result in direct contact of the tamper plate with the pipe. Care should be taken so that compaction around the spillway pipe does not cause uplift of the pipe resulting in a void beneath the pipe.
- For coarse grained materials (sands and gravels), vibratory plate compactors shall be used for obtaining compaction. However, hand tamping shall be used to compact the material under the bottom half of circular pipes.

In all cases, follow manufacturer instructions for the specific compaction equipment being used. Heavy equipment shall not be operated within 2 feet of any structure or pipe.

Compacting of fill adjacent to concrete structures shall not be started until the concrete is 7 days old.

7. ISLANDS, MOUNDS, AND LOAFING AREAS ON WETLAND RESTORATION, ENHANCEMENT, OR CREATION PROJECTS

Islands shall be randomly located within the wetland area at locations shown on the drawings or as staked in the field. The orientation of island shorelines shall be random with attention given to prevailing winds to limit wave damage. In general, the side of the island with the longest dimension shall be parallel to the prevailing wind direction. Side slopes of islands shall be as shown on the drawings, but in no case shall be steeper than 6 horizontal to 1 vertical. Island shapes shall be irregular.

Loafing areas shall be constructed in the areas shown on the drawings or as staked in the field and shall be graded to drain runoff water. The elevation of at least one loafing area should be above the maximum water level whenever possible.

Excavated material not suitable for embankments, wetland dikes, or islands can be used to create mounds or blended into surrounding topography to create a natural appearance. Spoil material shall not be spread on existing wetland areas.

Organic soils shall not be used to construct islands, loafing areas, dikes, or embankments.

Specific Site Requirements

A. Measurement and Payment

1. Compensation for any work item described in the contract documents but not listed in the bid schedule will be included in the payment for the item of work to which it is made subsidiary. Such items and bid items to which they are made subsidiary are identified in the Items of Work and Construction Details section of the Special Specification. For any item described in the bid documents, not included in any bid item, or not made subsidiary to any bid item in the Items of Work, shall be made subsidiary to the Mobilization bid item.
2. Quantities used for progress payments shall be considered as only approximate and provisional and shall be subject to recalculation, adjustment, and correction by the engineer in subsequent payment applications. Inclusion of any quantities in a progress payment, or failure to disapprove the work at the time of any progress payment, shall not be construed as acceptance of the corresponding work or materials.
3. For items of work which Unit Prices are established in the contract, the quantity of work will be measured, estimated, or based on plan quantity. The determination of quantities of work performed under the contract will be made by the Engineer with the assistance of the contractor and will be based on lines and grades shown on the plans and as given during the progress of work or as evidenced by approved tickets for weight or liquid measure or by measurements made or approved by the engineer. The contractor will be paid based on the actual quantity of work completed and accepted.

B. Items of Work and Construction Details

1. Items of work to be performed in conformance with this specification and the construction details therefore are:
 - a. **Bid item 8, Embankment, Terrace, and Core Trench Fill (P)**
 - a. This item shall consist of excavating, placing, and compacting the earthfill necessary to construct the embankment, terrace, core trench backfill, berms and adjacent fill areas shown on the plans.
 - b. Earthfill approved soil material shall be taken from excavation and designated borrow areas unless other areas are approved by the engineer.
 - c. Compaction shall be Method 2 for the embankment, terrace, spillway separation berm, and core trench. All other areas may be placed using Method 1 (tile cover and interior berms).
 - d. Rocks larger than 6" shall be removed prior to compaction.
 - e. Measurement and payment shall be on a plan "P" cubic yard basis. Plan basis, designated with a "P" in the proposal means that the plan quantity listed in the proposal will be used to measure and pay for the bid item regardless of the actual quantity.
 - f. A 25% shrinkage factor was used to determine plan quantity. Earthwork shall be balanced on site and may require minor field adjustments by the contractor.

- b. **Subsidiary Item, Backfill Required Excavation**
 - a. This item shall consist of backfilling the areas excavated to install other components related to the project such as piping or structures and to locate and remove the tile line.
 - b. Compaction adjacent to the structures shall be as indicated in section 6 of this specification.
 - c. No separate payment will be made for backfill required excavation. Compensation for this item will be included in payment for all excavations requiring backfill including but not limited to Bid item 6, 8, 10, 13, 14, 15, 16, 17, 19, 20, & 21 to which excavation is made subsidiary.



Construction Specification 000 IA-26 Topsoiling

1. SCOPE

The work shall consist of salvaging topsoil from borrow areas or required excavations and spreading it on the exposed disturbed areas.

2. QUALITY OF TOPSOIL

Topsoil shall consist of friable surface soil reasonably free of grass, roots, weeds, sticks, stones, or other foreign materials.

3. EXCAVATION

After the site has been cleared and grubbed, the topsoil shall be removed from borrow areas and required excavation areas to the depth as shown on the drawings. Topsoil shall be stockpiled at locations approved by the Engineer.

4. SPREADING

Spreading shall not be done when the ground or topsoil is frozen, excessively wet, or otherwise in a condition detrimental to the work. Surfaces designated to be covered shall be lightly scarified just prior to the spreading operation. Where compacted fills are designated to be covered by topsoil, the topsoil shall be placed concurrently with the fill and shall be bonded to the compacted fill with the equipment.

Topsoil shall be placed to the minimum depth shown on the drawings. After the spreading operation is completed, the surface shall be finished to a reasonably smooth surface.

Specific Site Requirements

A. Measurement and Payment

1. Compensation for any work item described in the contract documents but not listed in the bid schedule will be included in the payment for the item of work to which it is made subsidiary. Such items and bid items to which they are made subsidiary are identified in the Items of Work and Construction Details section of the Special Specification. For any item described in the bid documents, not included in any bid item, or not made subsidiary to any bid item in the Items of Work, shall be made subsidiary to the Mobilization bid item.
2. Quantities used for progress payments shall be considered as only approximate and provisional and shall be subject to recalculation, adjustment, and correction by the engineer in subsequent payment applications. Inclusion of any quantities in a progress payment, or failure to disapprove the work at the time of any progress payment, shall not be construed as acceptance of the corresponding work or materials.
3. For plan quantity bid items (denoted with (P) suffix on the bid item), the quantity will not be measured and will be paid based on the plan quantity. Contractors may dispute the plan quantity if they believe the actual quantity is substantially different than plan. The burden of proof for a dispute will be the responsibility of the contractor and will be considered by the engineer, if reasonable proof is provided.

B. Items of Work and Construction Details

1. Bid item 9, Topsoil, Strip, Stockpile and Respread
 - a. This item will consist of stripping, salvaging, stockpiling and resspreading salvaged (stockpiled) topsoil as the 6 inch surface layer of all excavations and earthfill areas shown on the plans.
 - b. Respread topsoil in all disturbed areas.
 - c. Measurement and payment for top soiling shall be on a plan "P" cubic yard basis. Plan basis, designated with a "P" in the proposal means that the plan quantity listed in the proposal will be used to measure and pay for the bid item regardless of the actual quantity.

**Construction Specification
000 IA-31 Concrete**

1. SCOPE

The work shall consist of furnishing, forming, placing, finishing, and curing Portland cement concrete including steel reinforcement.

2. MATERIALS

Portland Cement shall conform to ASTM C 150 and shall be Type I or Type II.

Fine Aggregates shall conform to ASTM C 33 and shall be composed of clean, uncoated grains of material.

Coarse Aggregates shall be gravel or crushed stone conforming to ASTM C 33 and shall be clean, hard, durable and free from clay or coating of any character. The maximum size of coarse aggregate shall be 1 1/2 inches or as shown on the drawings.

Water shall be clean and free from injurious amounts of oil, acid, salt, alkali, organic matter, or other deleterious substances.

Air entraining agent shall conform to ASTM C 260.

Fly ash may be used as a partial substitution for Portland cement and shall be in strict compliance with ASTM C 618, Class F or C. The loss by ignition shall not exceed 4.0 percent.

Blast-furnace slag may be used as a partial substitution for Portland cement and shall be in conformance with ASTM C 989 for ground granulated blast-furnace slag (GGBF slag).

Water-reducing admixtures shall conform to ASTM C 494 and may be the following types:

1. Type A - Water-reducing admixture
2. Type D - Water-reducing and retarding admixture
3. Type F - Water-reducing, high range admixture (superplasticizer).
4. Type G - water-reducing, high range, and retarding admixture (superplasticizer).

Type D or G admixture may be used when the air temperature is over 80 degrees F. at the time of mixing and/or placement.

Calcium Chloride or other antifreeze compounds or accelerators will not be allowed.

Preformed expansion joint filler shall be a commercially available product made of bituminous, sponge rubber or closed cell foam materials with a minimum thickness of 1/2 inch.

Reinforcing steel shall be free from loose rust, oil, grease, paint, or other deleterious matter. Reinforcing steel shall conform to one or more of the following:

1. Reinforcing Bars - ASTM A 615 or A 996 , Grade 40 or greater, deformed.
2. Welded Wire Fabric - ASTM A 185 or A 497.

Waterstops shall be either metallic or nonmetallic. Metallic waterstops shall be fabricated from sheets of copper or galvanized steel. Nonmetallic waterstops shall be made of natural or synthetic rubber or vinyl chloride polymer or copolymer. Rubber, polymer and copolymer waterstops shall have ribbed or bulb-type anchor flanges and a hollow tubular center bulb, unless otherwise shown on the drawings. All waterstops shall be of the sizes shown on the drawings.

Curing compound shall be a liquid membrane-forming compound suitable for spraying on the concrete surface. The curing compound shall meet the requirements of ASTM C 309 Type 2 (white pigmented).

3. CONCRETE DESIGN MIX

The contractor will be responsible for the determining the design mix proportions in accordance with the requirements included in this paragraph and shall provide a copy of the mix to the Engineer at

least 3 days prior to placing any concrete. The concrete mix shall be of such proportions as to provide a minimum strength of 3500 p.s.i. in 28 days, unless otherwise shown on the drawings. The air content shall be 4 to 8 percent of the volume of the concrete at the time of placement. The slump shall be 2 to 5 inches except when superplasticizer is used. The slump shall be 3 inches or less prior to the addition of superplasticizer admixture and shall not exceed 7 1/2 inches following addition and mixing. The fine aggregate shall be 30-50 percent of the total combined aggregate based on oven dry weights. The contractor shall provide tests to verify that the design mix meets the requirements. In lieu of this, one of the following mix proportions per cubic yard may be used:

<u>Mix Number</u>	<u>Minimum Cement, Pounds</u>	<u>Fly Ash, Pounds</u>	<u>GGBF Slag, Pounds</u>	<u>Maximum ** Water, Gallons</u>
1	564	0	0	33
2	470	45-90	0	31-34
3	517	129	0	31 *
4	366	114	91	31 *
5	259	103	155	31 *

** Total of available aggregate moisture, mixing water added at the plant and mixing water added at the job site (one gallon equals 8.33 pounds).

* Requires water reducing admixture.

4. MIXTURES AND MIXING

Ready-mixed concrete shall be batched, mixed and transported in accordance with ASTM C 94. Concrete shall be uniform and thoroughly mixed when delivered to the forms. No mixing water in excess of the amount shown for the design mix or in an amount that would cause the maximum slump to be exceeded shall be added to the concrete during mixing, hauling or after arrival at the point of delivery. The concrete shall be batched and mixed so that the temperature of the concrete at the time of placing shall be between 50 and 90 degrees F.

5. BATCH TICKET

The contractor shall obtain from the supplier a delivery ticket for each batch of concrete before unloading at the site. The following information shall be included on the ticket: name of concrete supplier, job name or location, date, truck number, amount of concrete, time loaded or time of first mixing cement, aggregate, and mixing water added at the plant, type and amount of cement, type and amount of admixtures, oven dry weights of fine and coarse aggregate, and moisture content(%) or weight of water contained in the aggregates.

The following information shall be added to the batch ticket on site: mixing water added on site, time concrete arrived on site and time concrete was unloaded.

Upon completion of the concrete placement, copies of all batch tickets shall be provided to the Engineer.

6. REINFORCING STEEL

Before reinforcement is placed, the surfaces of the bars or mesh shall be cleaned to remove any loose, flaky rust, mill scale, oil, grease, or other foreign substances. After placement, the reinforcement shall be maintained in a clean condition until it is completely embedded in the concrete.

Reinforcing bars shall be cut and bent according to ACI Standard 315.

Tack welding of bars shall not be permitted. Reinforcement shall be accurately placed as shown on the drawings and secured in position in a manner that will prevent its displacement during placement of concrete. Metal chairs, metal hangers, metal spacers or concrete chairs shall be used to support reinforcement. Precast concrete chairs shall be manufactured from concrete equal in quality to the concrete being placed. Precast concrete chairs shall be moist at the time concrete is placed

Splices of reinforcing bars shall be made only at the locations shown on the drawings, unless otherwise approved by the Engineer. All reinforcing splices and placement shall be in accordance with ACI 318 and shown on the drawings.

After placement of the reinforcement, concrete shall not be placed until the reinforcement has been inspected and approved by the Engineer.

7. PREPARATION OF FORMS AND SUBGRADE

Prior to placement of concrete, the forms and subgrade shall be free of woodchips, sawdust, debris, water, ice, snow, extraneous oil, mortar, or other harmful substances or coatings. Any oil on the reinforcing steel or other surfaces required to be bonded to the concrete shall be removed. All surfaces shall be firm and damp prior to placing concrete. Placement of concrete on mud, dried earth, uncompacted fill, or frozen subgrade will not be permitted.

The forms and associated false-work shall be substantial and unyielding and shall be constructed so that the finished concrete will conform to the specified dimensions and elevations. Forms will be mortar tight. Forms with torn surfaces, worn edges, dents or other defects will not be used. Forms shall be coated with a nonstaining form release agent before being set into place. Excess form coating material shall not stand in puddles in the forms or come in contact with the steel reinforcement or hardened concrete against which fresh concrete is to be placed.

Form accessories to be partially or wholly embedded in the concrete, such as ties and hangers, shall be of a commercially manufactured type. Non fabricated wire shall not be used. Form ties shall be constructed so that the ends or end fasteners can be removed without causing spalling at the surface of the concrete.

Metal form ties used within the forms on structures with a total volume of concrete exceeding fifteen cubic yards shall be equipped with cones or other devices that permit their removal to a depth of at least one inch without damage to the concrete. The holes resulting from cones and other devices shall be patched in accordance with Section 9.

Form ties except those specifically covered by the preceding paragraph shall be broken off flush with the formed surface. Any surface areas which have been spalled or otherwise damaged shall be repaired in accordance with Section 9.

Steel tying and form construction adjacent to new concrete shall not be started until concrete has cured at least 12 hours.

Concrete joints shall be of the type and at the locations shown on the drawings.

Splices in metal waterstops shall be brazed, welded or overlapped and bolted. Splices in nonmetallic waterstops shall be cemented or joined as recommended by the manufacturer.

8. PLACING CONCRETE

Concrete shall not be placed until the subgrade, forms, and steel reinforcement have been inspected and approved by the Engineer. Any deficiencies are to be corrected before the concrete is delivered for placement.

Concrete shall be delivered to the site and discharged into the forms within 1 1/2 hours after the introduction of the cement to the aggregates. When a superplasticizer is used, the concrete shall be discharged within the manufacturer's recommended time limit for discharge after addition of the admixture. In hot weather or under conditions contributing to quick setup of the concrete, discharge of the concrete shall be accomplished in 45 minutes unless a set-retarding admixture is used, in which case the manufacturer's recommended time limit will apply.

Addition of water at the job site may be done at the beginning of placement of each load of concrete in order to obtain allowable slump, provided that the maximum water content and water/cement ratio in the design mix is not exceeded. Addition of water will not be permitted after placement of the load has started.

The concrete shall be deposited as closely as possible to its final position in the forms and shall be worked into corners and around reinforcement and other embedded items in a manner which prevents segregation. Formed concrete shall be deposited in layers 24 inches or less in depth and shall be continuously deposited so that no concrete will be deposited on concrete which has hardened sufficiently to cause the formation of "cold joints". Concrete containing superplasticizer shall be placed in lifts not exceeding 5 feet in depth. If the surface layer of concrete sets during placement to the degree that it will not flow and merge with the succeeding layer when tamped or vibrated, the contractor shall discontinue placing concrete and install a construction joint. Construction joints shall be completed as shown on the drawings or by one of the following methods:

1. The joint shall be constructed using a 6 inch wide by 1/4 inch steel plate. The surfaces of the construction joint shall be prepared by washing and scrubbing with a wire brush or wire broom to expose coarse aggregate. The steel plate shall be embedded 3" in the concrete.
2. The joint surface shall be cleaned to expose coarse aggregate by sandblasting or air-water cutting after the concrete has gained sufficient strength to prevent displacement of the coarse aggregate or cement fines. The surface of the concrete shall not be cut so deep as to undercut the coarse aggregate. The joint shall be washed to remove all loose material after cutting.

The surfaces of all construction joints shall be kept continuously moist for at least 1 hour prior to placement of the new concrete. The new concrete shall be placed directly on the cleaned and washed surface. New concrete shall not be placed until the hardened concrete has cured at least 12 hours.

Concrete shall not be dropped more than 5 feet vertically unless suitable equipment is used to prevent segregation. Concrete containing superplasticizer shall not be dropped more than 12 feet vertically.

Immediately after the concrete is placed in the forms, it shall be consolidated by vibration, spading or hand tamping as necessary to insure smooth surfaces and dense concrete. Care should be taken not to over-vibrate concrete containing superplasticizer. Vibration shall not be supplied directly to the reinforcing steel, the forms or concrete which has hardened to the degree that it does not insure a monolithic bond with the preceding layer. The use of vibrators to transport concrete in the forms or conveying equipment will not be permitted.

9. FORM REMOVAL AND FINISHING

Forms shall be left in place for at least 24 hours after placing concrete. Forms shall be removed in such a way as to prevent damage to the concrete. Supports shall be removed in a manner that will permit concrete to take the stresses due to its own weight uniformly and gradually.

Immediately after removal of the forms, concrete which is honey combed, damaged or otherwise defective shall be repaired or replaced. All cavities or depressions resulting from form tie removal shall be patched with a non-shrink grout, mortar mix or epoxy-type sealer. Non-shrink grout consists of 1 part cement and 2-1/2 parts sand that will pass a No. 16 sieve. Only enough water shall be added to produce a filling which is at the point of becoming rubbery when the material is solidly packed.

All repaired and patched areas shall be cured as required in Section 10.

10. CURING

Concrete shall be cured for a period of not less than 7 consecutive days by one of the following approved methods:

1. Membrane Curing: Concrete shall be cured with white pigmented curing compound. The compound shall be sprayed on moist concrete as soon as free water has disappeared, but shall not be applied to any surface until patching, repairs and finishing of that surface are completed. Curing compound shall not be applied to surfaces requiring bond to subsequently placed concrete, such as construction joints, shear plates, reinforcing steel, and other embedded items. Surfaces subjected to heavy rainfall or running water within 3 hours after curing compound has been applied or surfaces damaged by subsequent construction operations during the curing period, shall be reapplied in the same manner as the original application.

2. Moist Curing: Concrete shall be cured by maintaining all surfaces continuously wet for the entire curing period.
3. Cover: Adequately cover an exposed structure with burlap mats, or other material and continually soak with water.

11. BACKFILLING

Backfilling may begin when the curing period has ended. Backfill against the structure will be placed in no more than 4-inch layers and compacted by hand tamping or with manually directed power tampers or plate vibrators. Layers compacted in this manner shall extend not less than 2 feet from any part of the concrete structure.

12. HOT AND COLD WEATHER CONCRETING

When the atmospheric temperature may be expected to drop below 40o F. at the time concrete is delivered to the work site , during placement, or at any time during curing period, concrete shall be mixed, placed and protected in accordance with ACI Standard 306, "Recommended Practice for Cold Weather Concreting."

When climatic or other conditions are such that the temperature of the concrete may reasonably be expected to exceed 90o F. at the time of delivery to the work site, during placement or during the first 24 hours after placement, concrete shall be mixed, placed and protected in accordance with ACI Standard 305, "Recommended Practice for Hot Weather Concreting."

Specific Site Requirements

A. Measurement and Payment

1. Compensation for any work item described in the contract documents but not listed in the bid schedule will be included in the payment for the item of work to which it is made subsidiary. Such items and bid items to which they are made subsidiary are identified in the Items of Work and Construction Details section of the Special Specification. For any item described in the bid documents, not included in any bid item, or not made subsidiary to any bid item in the Items of Work, shall be made subsidiary to the Mobilization bid item.
2. Quantities used for progress payments shall be considered as only approximate and provisional and shall be subject to recalculation, adjustment, and correction by the engineer in subsequent payment applications. Inclusion of any quantities in a progress payment, or failure to disapprove the work at the time of any progress payment, shall not be construed as acceptance of the corresponding work or materials.
3. For items of work which Unit Prices are established in the contract, the quantity of work will be measured, estimated, or based on plan quantity. The determination of quantities of work performed under the contract will be made by the Engineer with the assistance of the contractor and will be based on lines and grades shown on the plans and as given during the progress of work or as evidenced by approved tickets for weight or liquid measure or by measurements made or approved by the engineer. The contractor will be paid based on the actual quantity of work completed and accepted.

B. Items of Work and Construction Details

1. Items of work to be performed in conformance with this specification and the construction details therefore are:
 - a. Subsidiary Item – Concrete
 - (1) This item shall consist of furnishing and placing poured concrete and reinforced concrete as shown on the drawings for the water control structure, flared end section footing, drain tile outlets, tile repair connections, and any other item where concrete is shown on the plans.
 - (2) No separate payment will be made for Concrete.
 - (3) Concrete is subsidiary to items required for installation such as structure excavation, earthfill, site preparation, removal of water, concrete collar at joint, animal guard, erosion controls and all necessary appurtenances as shown in the drawings. Bid items to which concrete is subsidiary include but are not limited to Bid Items 6, 13, 14, 15, 16, 17, 19, 20, and 21.

Construction Specification 000 IA-46 TILE DRAINS FOR LAND DRAINAGE

1. SCOPE

The work shall consist of furnishing and installing drainage pipe (tubing) and tile and the necessary fittings and appurtenances.

2. MATERIALS

Concrete drain tile shall conform to the requirements of ASTM C 412 and clay drain tile shall conform to the requirements of ASTM C 4.

Corrugated polyethylene (PE) pipe (tubing) and fittings shall conform to ASTM F 405 (3" to 6") or F 667 (3" to 24"), as appropriate. Corrugated profile wall (dual wall) polyethylene (PE) pipe shall meet or exceed the requirements of ASTM F 2648 (2" to 60") or ASTM F 2306 (12" to 60"). Pipe conforming to AASHTO M 252 (3" to 10"), or AASHTO M 294 (12" to 60") is acceptable. Perforated tubing shall have a water inlet area of at least 1 square inch per foot, provided by perforations spaced uniformly along the long axis of the tubing. The perforations shall be circular or slots. Circular perforations shall not exceed 3/16 inch in diameter. Slots shall not be more than 1/8 inch wide.

3. EXCAVATION

Unless otherwise specified, excavation for and subsequent installation of each drain line shall begin at the outlet end and progress upstream.

The trench or excavation for the conduit shall be constructed to the line, depth, cross section, and grade shown on the drawings, or as directed by the Engineer. The trench bottom shall be smooth and free of exposed rock. If rock is encountered in the trench bottom, over-excavate the trench and place at least 6 inches of compacted earth or sand bedding in the trench to bring it up to the conduit grade.

If not otherwise shown on the drawings, trench width at the top of the conduit shall be the minimum required to permit installation and provide bedding conditions suitable to support the load on the conduit, but with not less than three (3) inches of clearance on each side of the conduit. Maximum trench width shall be the conduit diameter plus 12 inches measured at the top of the conduit, unless approved bedding is installed.

Trench shields, shoring and bracing, or other methods, necessary to safeguard the workers and work, and to prevent damage to the existing improvements shall be furnished, placed, and subsequently removed by the contractor.

Plow installation is allowed. Minimum trench width shall be two (2) inches wider than the conduit on each side. Grade control and bedding conditions shall be closely inspected during plow installation. Boulders, cobbles, or cemented soils can cause the plow to jump and lose grade. These hardpoints can also puncture or dimple and deform the pipe.

4. PREPARING THE BEDDING

Unless otherwise specified, no filter or envelope is required. In stable soils, the bottom of the trench shall be shaped to form a semicircular, trapezoidal, or 90-degree "V" groove in its center. The groove shall be shaped to fit the size of tile. The 90-degree "V" groove shall not be used on conduits greater than 6 inches in diameter.

If the bottom of the trench does not provide a sufficiently stable or firm foundation for the drain tile, a sand-gravel mix or other approved materials shall be used to stabilize the bottom of the trench.

5. FILTER OR ENVELOPE MATERIAL

When a filter is specified, the shape of the bottom of the trench, gradation and the thickness of the filter or envelope material to be placed around the conduit will be as shown on the drawings. The envelope or filter material shall be placed in the bottom of the trench just prior to the laying of the conduit. The conduit shall then be laid and the envelope or filter material placed over the conduit.

6. PLACEMENT AND JOINT CONNECTIONS

All drains shall be laid to grade.

Joints between lateral concrete and clay drain tiles shall vary with soil type as follows:

Peat and muck - 1/4 inch preferred, 3/8 inch maximum

Clay - 1/8 inch preferred, 1/4 inch maximum

Silt and loam - 1/16 inch preferred, 1/8 inch maximum

Sand - tightest possible fit.

Joints between main drain tile, which serve only to collect and transport drainage water from lateral tile lines, should be the tightest fit possible.

Where the joint width exceeds the maximum above, the joint shall be covered with a permanent type material such as coal tar pitch treated roofing paper, fiber glass sheet or mat, or plastic sheet.

After placement and blinding of plastic tubing, but prior to backfilling, sufficient time shall elapse to allow the tubing to reach the ambient temperature of the trench. All split fittings shall be securely tied with nylon cord before backfill is placed. When corrugated plastic tubing is used, no more than 5% stretch will be allowed.

7. CONNECTIONS

Lateral connections will be made with manufactured appurtenances (wyes, tees, etc.) comparable in strength and durability with the specified conduit unless otherwise shown on the drawings.

Existing drain lines not shown on the drawings but encountered during installation shall be bridged across the trench or connected into the new line, as directed by the Engineer.

Connections with the outlet pipe shall be made watertight.

8. OUTLETS

A continuous section of non-perforated conduit at least 20 feet long shall be used at the outlet. At least two-thirds of the outlet pipe shall be buried in the ditch bank, and the cantilever section must extend to the toe of the ditch side slope or the side slope protected from erosion. Acceptable materials for use at the outlet include the following:

- A. Corrugated metal pipe, galvanized or aluminum, 16 gauge minimum;
- B. Smooth steel pipe with a minimum wall thickness of 3/16 inch;
- C. Smooth plastic pipe, polyvinyl chloride (PVC), with a SDR of 26 or less or schedule 40 or heavier;
or
- D. Corrugated profile wall (dual wall) polyethylene pipe (PE).

All plastic (PVC) and polyethylene pipe (PE) outlets shall include ultra-violet stabilizer. PVC and PE pipe outlets shall not be used where burning vegetation on the outlet ditch bank is likely to create a fire hazard.

The outlet shall be equipped with a flap-gate type rodent guard.

9. BLINDING

After the conduit is placed in the excavated groove, friable material from the sides of the trench shall be placed around the conduit, completely filling the trench to a depth of not less than six

(6) Inches over the top of the conduit. For material to be suitable it must not contain hard clods, rocks, frozen soil, or fine material which will cause a silting hazard to the drain. Conduit placed during any one day shall be blinded by the end of the day's work.

10. BACKFILLING

The backfilling of the trench shall be completed as rapidly as consistent with the soil conditions. Automatic backfilling machines may be used. Backfill shall extend above the ground surface and be well rounded over the trench.

Unless otherwise shown on the plans, in mineral soils, the minimum depth of cover over subsurface drains shall be 2.4 feet. In organic soils, the minimum depth of cover after initial subsidence shall be 3.0 feet.

Special Site Requirements

A. Measurement and Payment

1. Compensation for any work item described in the contract documents but not listed in the bid schedule will be included in the payment for the item of work to which it is made subsidiary. Such items and bid items to which they are made subsidiary are identified in the Items of Work and Construction Details section of the Special Specification. For any item described in the bid documents, not included in any bid item, or not made subsidiary to any bid item in the Items of Work, shall be made subsidiary to the Mobilization bid item.
2. Quantities used for progress payments shall be considered as only approximate and provisional and shall be subject to recalculation, adjustment, and correction by the engineer in subsequent payment applications. Inclusion of any quantities in a progress payment, or failure to disapprove the work at the time of any progress payment, shall not be construed as acceptance of the corresponding work or material
3. For plan quantity bid items (denoted with (P) suffix on the bid item), the quantity will not be measured and will be paid based on the plan quantity. Contractors may dispute the plan quantity if they believe the actual quantity is substantially different than plan. The burden of proof for a dispute will be the responsibility of the contractor and will be considered by the engineer, if reasonable proof is provided.

B. Items of Work and Construction Details

1. Items of work to be performed in accordance with this specification and the construction details therefore are:
 - a. Bid Item 20 – 12" NON-PERFORATED DUAL WALL HDPE FIELD FILE
 - (1) This item will consist of furnishing and installing dual wall non-perforated 12-inch diameter corrugated polyethylene tubing used as drain tile as shown on the drawings.
 - (2) HDPE Pipe shall meet ASTM F 2648 or ASTM F3390 (Flexible Dual Wall Piping).
 - (3) Joints shall be gasketed and shall be water tight.
 - (4) Minimum Cover over all tile shall be 3 feet.
 - (5) Coupling bands, repair of damaged tile, prefabricated fittings and other appurtenances are subsidiary to this item and shall not warrant separate payment.
 - (6) Measurement and payment for shall be on an installed linear foot basis, and shall include all necessary fittings and adapters.
 - b. Bid Item 19 – 8" NON-PERFORATED DUAL WALL HDPE FIELD FILE
 - (1) This item will consist of furnishing and installing dual wall non-perforated 8-inch diameter corrugated polyethylene tubing used as drain tile as shown on the drawings.
 - (2) HDPE Pipe shall meet ASTM F 2648 or ASTM F3390 (Flexible Dual Wall Piping).
 - (3) Joints shall be gasketed and shall be water tight.
 - (4) Minimum Cover over all tile shall be 3 feet.
 - (5) Coupling bands, repair of damaged tile, prefabricated fittings and other appurtenances are subsidiary to this item and shall not warrant separate payment.
 - (6) Measurement and payment shall be on an installed linear foot basis, and shall include all necessary fittings and adapters.

c. Subsidiary Item: Pre-fabricated HDPE Bends and Fittings

- (1) This item will consist of furnishing and installing necessary prefabricated HDPE tile bends, angles, couplers, or other required appurtenances to install the filed tile as shown on the plans.
- (2) No separate payment will be made for prefabricated bends, fittings, angles or other required appurtenances to install the field tile as shown on the plans. Payment for this item of work is made subsidiary to tile bid items 19 and 20.

d. Subsidiary Item: Connections to existing tiles

- (1) No separate payment will be made for connections to existing tiles. Payment for this item of work is made subsidiary to tile bid items 19 and 20.

**Construction Specification
000 IA-51 Corrugated Metal Pipe Conduits**

1. SCOPE

The work shall consist of furnishing and placing circular, arched or elliptical corrugated metal pipe and the necessary fittings.

2. MATERIALS

Metallic-coated steel corrugated pipe and fittings shall be zinc-coated or aluminized, Type 2, and shall conform to the requirements of ASTM A 760 and A 929 for the specified type and size of pipe. Aluminum corrugated pipe shall conform to the requirements of ASTM B 745 for the specified type and size of pipe. All pipe is subject to the following additional requirements:

1. When polymer coating is specified, pipe, coupling bands and anti-seep collars shall be coated in accordance with ASTM A 762. All riveted joints shall be caulked as described in paragraph B.
2. Pipe with annular corrugations shall be furnished with caulked seams. Riveted pipe joints shall be caulked with a bituminous mastic material during fabrication to provide a watertight joint. All circumferential and longitudinal seams shall be caulked before riveting. This shall be accomplished by applying a uniform bead of the mastic compound to the inner lap surface before riveting such that when the rivets are in place, all voids are filled and a coating of mastic is between the lap surfaces. The inner surface of coupling bands shall be asphalt coated in the field prior to installation. A neoprene gasket having a minimum thickness of 3/8 inch and a minimum width of 7 inches may be used in lieu of mastic coated coupling bands.
3. Welded or lock seams in helical corrugated pipe are considered to be watertight.
4. When close riveted pipe is specified: (1) the pipe shall be fabricated so that the rivet spacing in the circumferential seams shall not exceed 3 inches, except that 12 rivets will be sufficient to secure the circumferential seams in 12-inch pipe, and (2) in those portions of the longitudinal seams that will be covered by the coupling bands, the rivets shall have finished flat heads or the rivets and holes shall be omitted and the seams shall be connected by welding to provide a minimum of obstruction to the seating off the coupling bands.
5. Double riveting or double spot welding of pipe less than 42 inches in diameter may be required. If specified, the riveting or welding shall be done in the manner specified for pipe 42 inches or greater in diameter.

3. COUPLING BANDS

Coupling bands shall meet the requirements of the table below or have detailed drawings submitted for approval by the State Conservation Engineer. Coupling bands shall be of the same minimum thickness (gage) as the pipe being connected.

4. FABRICATION

Fabrication of all appurtenances shall be done as shown on the drawings. All appurtenances shall be made of metallic-coated steel when corrugated steel pipe is used and aluminum when used with aluminum pipe. Dissimilar metals shall not be installed in contact with each other.

Description of Coupling Band	Maximum Fill Height, Ft.	Maximum Pipe Diam., In.
24-inch wide coupling band with four 1/2-inch Diam. galvanized rods with tank lugs for annular or helical corrugated metal pipe. Bands shall have a minimum lap of 3 inches.	All	All

Description of Coupling Band	Maximum Fill Height, Ft.	Maximum Pipe Diam., In.
Hugger band from Armco Steel Corp. for helical corrugated metal pipe with reformed ends; and for annular corrugated pipe. Bands include O-ring gaskets and two 1/2-inch Diam.	35	48
Hugger band without rods and lugs but Angles riveted or welded to a coupling band and drawn tight with bolts. Bands shall be a minimum of 7 corrugations wide and have a minimum lap of 2 inches.	20	24
Flanged couplings for helical corrugated pipe welded to the ends of the pipe and field assembled by a minimum of 3/8-inch Diam. bolts. A joint sealer shall be placed between the flanges to ensure water tightness.	35	15
	25	12
<u>1/</u> Use is limited to sites where soft foundation and conduit elongation is not anticipated.		

5. REPAIR OF DAMAGED COATINGS

The Contractor shall place the pipe without damaging the pipe or coatings. The pipe shall be transported and handled in a manner to prevent damage to the pipe or coating.

Breaks, scuffs, or other damage to the various coatings shall be repaired as follows:

1. Metallic Coating - by thoroughly wire brushing the damaged area and cleaning with solvent, and then painting two coats of one of the following paints:
 - a. Zinc Dust - Zinc Oxide Primer conforming to ASTM D 79 and D 520.
 - b. Single package, moisture cured urethane prime in silver metallic color.
 - c. Zinc-rich cold galvanized compound, brush, or aerosol applications.
2. Polymer Coating - apply two coats of polymer material similar to and compatible with the durability, adhesion and appearance of the original polymer coating. The repair coating shall be a minimum thickness of 0.010 (10 mils) after drying and shall bond securely to the pipe.

6. LAYING AND BEDDING THE PIPE

The pipe shall be laid to the line and grade shown on the drawings and shall be firmly and uniformly bedded throughout its entire length. Details of the bedding are as shown on the drawings.

The pipe shall be laid with the outside laps of circumferential joints pointing upstream and with longitudinal laps on the sides at approximately the vertical mid-height of the pipe. Field welding of corrugated galvanized steel pipe will not be permitted. The pipe sections shall be joined with coupling bands.

7. BACKFILLING

Special care shall be taken during backfill operations not to disturb the grade and alignment.

The pipe shall be tied down or loaded sufficiently during backfilling around the sides to prevent its being lifted from the bedding.

Backfill material shall have sufficient moisture so that optimum compaction can be obtained. Backfill around the pipe shall be placed in layers not more than 4 inches thick before compaction.

Each layer of backfill shall be compacted with power tampers, hand tampers, or plate vibrators to the same density requirements as specified for the adjacent embankment. Backfill over and around the pipe

shall be brought up uniformly on all sides. The passage of earth moving equipment will not be allowed over the pipe until backfill has been placed above the top of the pipe surface to a depth of two (2) feet.

Specific Site Requirements

A. Measurement and Payment

1. Compensation for any work item described in the contract documents but not listed in the bid schedule will be included in the payment for the item of work to which it is made subsidiary. Such items and bid items to which they are made subsidiary are identified in the Items of Work and Construction Details section of the Special Specification. For any item described in the bid documents, not included in any bid item, or not made subsidiary to any bid item in the Items of Work, shall be made subsidiary to the Mobilization bid item.
2. Quantities used for progress payments shall be considered as only approximate and provisional and shall be subject to recalculation, adjustment, and correction by the engineer in subsequent payment applications. Inclusion of any quantities in a progress payment, or failure to disapprove the work at the time of any progress payment, shall not be construed as acceptance of the corresponding work or materials.
3. For items of work which Unit Prices are established in the contract, the quantity of work will be measured, estimated, or based on plan quantity. The determination of quantities of work performed under the contract will be made by the Engineer with the assistance of the contractor and will be based on lines and grades shown on the plans and as given during the progress of work or as evidenced by approved tickets for weight or liquid measure or by measurements made or approved by the engineer. The contractor will be paid based on the actual quantity of work completed and accepted.

B. Items of Work and Construction Details

1. Bid item 13 - CMP WATER CONTROL STRUCTURE
 - a. This item will consist of furnishing and installing the water control structure and all associated appurtenances.
 - b. Structure shall be CRCS 12GA Aluminized CMP.
 - c. Corrugations shall be 2 2/3" x 1/2"
 - d. Structure shall include a fabricated stoplogs, reinforced concrete, channel, lifting hooks, and grate lid as detailed on the plans. Submit shop drawings for review and approval prior to manufacturing.
 - e. Lump sum payment will constitute full compensation for this bid item as related subsidiary items.
2. Bid item 14 – 18" ALUMINIZED CMP DRAWDOWN PIPE, 14GA
 - a. This item will consist of furnishing and installing the 18" CMP and fittings as shown on the plans.
 - b. CMP shall be 14GA Aluminized CMP.
 - c. Corrugations shall be 2 2/3" x 1/2"
 - d. Installation shall include anti-seepage collars as shown on plans.
 - e. Installation shall include flared end sections and footings as shown on plans.
 - f. Linear foot measurement and payment will constitute full compensation for this bid item and related subsidiary items.
 - g. Subsidiary Item: Internally mounted rodent guard where applicable.

3. Bid Item 17- 24" ALUMINIZED CMP DRAWDOWN RISER, 12 GA
 - a. This item will consist of furnishing and installing the 24" CMP Riser and Trash Rack as detailed.
 - b. CMP shall be CRCS 12GA Aluminized CMP.
 - c. Lump sum payment will constitute full compensation for this bid item as related subsidiary items.
4. Bid Item 15 - 15" ALUMINIZED CMP, 16GA, TILE OUTLET
 - a. This item will consist of furnishing and installing the 20 LF sections of 15" Tile outlet section on the proposed 12-inch tile.
 - b. CMP shall be 16GA Aluminized CMP.
 - c. Linear foot measurement and payment will constitute full compensation for this bid item and related subsidiary items.
5. Bid Item 16 - 12" ALUMINIZED CMP, 16GA, TILE OUTLET
 - a. This item will consist of furnishing and installing 20 LF sections of 12" CMP outlet section on the proposed 8-inch tiles.
 - b. CMP shall be 16GA Aluminized CMP.
 - c. Linear foot measurement and payment will constitute full compensation for this bid item and related subsidiary items.
6. Bid Item 21 - 12" ALUMINIZED CMP TILE INTAKE RISER (12 GA) AND HEAVY DUTY BAR GUARD
 - a. This item will consist of furnishing and installing a 12" perforated surface inlet as shown on the drawings and connection to the existing tile.
 - b. Riser shall be slotted 12GA Aluminized CMP.
 - c. Subsidiary item: Bar Guard, Pipe, Posts, concrete connection and detailed appurtenances on plans.
 - d. Measurement and payment for Bid Item 21 shall be for each riser installed and shall include all necessary fittings and appurtenances.
7. Subsidiary Item: Flared End section and footing
 - a. This item will consist of furnishing and install the flared end sections and footings as shown on the plans.
 - b. No separate payment will be made for the flared end section and footing. Payment for this item will be considered subsidiary to Bid Item 14.
8. Subsidiary Item: Anti-Seepage Collars
 - a. This item will consist of furnishing and install the anti-seepage collars as shown on the plans.
 - b. No separate payment will be made for the anti-seepage collars. Payment for this item will be considered subsidiary to Bid Item 14.

Construction Specification 000 IA-61 Loose Rock Riprap

1. SCOPE

The work shall consist of the construction of loose rock riprap revetments, structures and blankets, including filter layers or bedding where specified.

2. MATERIALS

Rock for loose rock riprap, filter layers or bedding shall come from sources approved by the Engineer. The rock shall be excavated, selected and handled as necessary to meet the quality and grading requirements of this specification and the construction drawings.

Individual rock fragments shall be dense, sound and free from cracks, seams and other defects conducive to accelerated weathering. The rock fragments shall be angular to sub rounded in shape. The least dimension of an individual rock fragment shall not be less than 1/3 the greatest dimension of the fragment unless otherwise specified on the construction drawings.

3. SUBGRADE PREPARATION

The subgrade surfaces on which the riprap or bedding is to be placed shall be cut or filled and graded to the lines and grades shown on the drawings. When fill to subgrade lines is required, it shall consist of approved materials and shall be compacted to a density equal to the adjacent existing soil material.

Rock materials shall not be placed until the foundation preparation is completed and the subgrade surfaces have been inspected and approved by the Engineer.

4. EQUIPMENT-PLACED ROCK RIPRAP

Rock shall be placed by equipment on the surfaces and to the depths specified. The riprap shall be constructed to the full thickness in one operation and in such a manner as to avoid serious displacement of the underlying materials. The rock shall be delivered and placed in a manner that will insure that the riprap in place shall be reasonably homogeneous with the larger rocks uniformly distributed and firmly in contact, one to another, with the smaller rocks and spalls filling the voids between the larger rocks. Placement of rock shall begin at the bottom of the slope or downstream end of the structure.

Riprap shall be placed in a manner to prevent damage to structures. Hand placing will be required to the extent necessary to prevent damage to adjacent structures.

5. HAND-PLACED RIPRAP

Rock shall be placed by hand on the surfaces and to the depths specified. It shall be securely bedded with the larger rocks firmly in contact, one to another. Spaces between the larger rocks shall be filled with smaller rocks and spalls. Smaller rocks shall not be grouped as a substitute for larger rock. Flat slab rock shall be laid on edge unless otherwise specified. Placement of rock shall begin at the bottom of the slope or downstream end of the structure.

6. FILTER LAYERS OR BEDDING

When the drawings specify filter layers or bedding beneath riprap, the filter or bedding material shall be spread uniformly on the prepared subgrade surfaces to the depth specified. Compaction of filter layers or bedding will not be required, but the surface of such layers shall be finished reasonably free of mounds, dips or windrows.

Specific Site Requirements

A. Measurement and Payment

1. Compensation for any work item described in the contract documents but not listed in the bid schedule will be included in the payment for the item of work to which it is made subsidiary. Such items and bid items to which they are made subsidiary are identified in the Items of Work and Construction Details section of the Special Specification. For any item described in the bid documents, not included in any bid item, or not made subsidiary to any bid item in the Items of Work, shall be made subsidiary to the Mobilization bid item.
2. Quantities used for progress payments shall be considered as only approximate and provisional and shall be subject to recalculation, adjustment, and correction by the engineer in subsequent payment applications. Inclusion of any quantities in a progress payment, or failure to disapprove the work at the time of any progress payment, shall not be construed as acceptance of the corresponding work or materials.
3. For items of work which Unit Prices are established in the contract, the quantity of work will be measured, estimated, or based on plan quantity. The determination of quantities of work performed under the contract will be made by the Engineer with the assistance of the contractor and will be based on lines and grades shown on the plans and as given during the progress of work or as evidenced by approved tickets for weight or liquid measure or by measurements made or approved by the engineer. The contractor will be paid based on the actual quantity of work completed and accepted.

B. Items of Work and Construction Details

1. Items of work to be performed in accordance with this specification and the construction details therefore are:
 - a. Bid item 11 – RIP RAP, CLASS 'E' WITH GEOTEXTILE FABRIC
 - (1) This item shall consist of furnishing and placing Rock Riprap upstream and downstream of the sheet pile weir, drawdown structure inlet, rock checks, tile outlets and as shown on the plans.
 - (2) Rock Riprap shall meet the requirements of IDOT Class 'E' revetment.
 - (3) All Riprap to be placed in zones to be grouted shall be screened over an 8-inch Grizzly screen to remove material less than 8 inches.
 - (4) Measurement and payment for Rock Riprap shall be on a per ton basis, rounded to the nearest ton. Weigh tickets shall be provided to the Engineer for all Rock Riprap.
 - (5) Subsidiary Item - Geotextile Fabric, IA-95: No separate payment will be made for geotextile.
 - b. Bid item 18 – 3" CLEAN STONE
 - (1) This item shall consist of furnishing and placing washed, 3-inch clean stone at the construction entrance.
 - (2) Measurement and payment for stone shall be on a per ton basis, rounded to the nearest ton. Weigh tickets shall be provided to the Engineer.

Construction Specification 000 IA-62 Concrete Grout for Riprap

1. SCOPE

The work shall consist of furnishing, transporting, and placing concrete grout in the construction of grouted rock riprap sections as shown on the drawings.

2. MATERIALS

Cement shall be Type I or Type II Portland cement conforming to ASTM C 150. Fly ash shall be in strict compliance with ASTM C 618, Class F or C. It may be used as a partial substitution for Portland cement for amounts not to exceed 20 percent of the total amount of cementitious material in the grout. The loss by ignition shall not exceed 4.0 percent. Fine aggregate shall conform to ASTM C 33 and shall be composed of clean, uncoated grains of material. Water shall be clean and free of harmful chemicals. Air entraining admixtures shall conform to ASTM C 260.

3. GROUT MIX

The grout mix shall be as follows:

1. Cement: 10 sacks or 940 pounds per cubic yard
2. Fine concrete aggregate: 2,100 pounds per cubic yard
3. Water: 45 gallons per cubic yard or enough to provide a thick creamy consistency
4. Air content: 6 to 10 percent.

When ready-mixed grout is furnished, the contractor shall furnish to NRCS a delivery ticket showing the time of loading and the quantities of materials used for each load of grout mix.

No mixing water in excess of the amount called for in the grout mix shall be added during mixing, hauling or after arrival of the mix at the delivery point.

4. CONVEYING AND PLACING

Grout mix shall be delivered to the site and placed within 1 1/2 hours after the introduction of the cement to the aggregates. In hot weather or under conditions contributing to quick setup of the grout mix, discharge of the concrete shall be accomplished in 45 minutes unless a set-retarding admixture is used, in which case the manufacturer's recommended time limit will apply.

Grout mix shall not be dropped more than 5 feet vertically unless suitable equipment is used to prevent segregation.

The grout mix shall not be placed until the rock riprap has been inspected and approved.

Rock to be grouted shall be kept wet for at least 2 hours immediately prior to grouting. Grout shall not be placed in standing or flowing water.

The grout shall be consolidated by spading or mechanical vibration. The grout shall not be forced to flow laterally to its final location.

The average rate of grout application shall be 5.4 cubic feet per square yard of riprap (0.6 cubic feet per square foot).

5. CURING CONCRETE

Concrete shall be cured for 7 days by either:

1. Applying white pigmented curing compound at a rate of 1 gallon per 150 square feet or as recommended by the manufacturer.
2. Water soak exposed surface for the entire 7 days.
3. Cover with burlap, mats or other material and maintain in a moist condition.
4. Cover with four (4) mil plastic sheeting while concrete is still wet.

Grout mix shall not be placed when daily minimum temperatures are expected to be lower than 40 degrees F unless facilities are provided to maintain the temperature of the materials at 50 to 90 degrees F during the placement and curing period. Grout may not be placed on frozen surfaces. When freezing conditions are expected, rock shall be heated to 50 to 90 degrees F for at least 24 hours prior to placing grout.

Specific Site Requirements

A. Measurement and Payment

1. Compensation for any work item described in the contract documents but not listed in the bid schedule will be included in the payment for the item of work to which it is made subsidiary. Such items and bid items to which they are made subsidiary are identified in the Items of Work and Construction Details section of the Special Specification. For any item described in the bid documents, not included in any bid item, or not made subsidiary to any bid item in the Items of Work, shall be made subsidiary to the Mobilization bid item.
2. Quantities used for progress payments shall be considered as only approximate and provisional and shall be subject to recalculation, adjustment, and correction by the engineer in subsequent payment applications. Inclusion of any quantities in a progress payment, or failure to disapprove the work at the time of any progress payment, shall not be construed as acceptance of the corresponding work or materials.
3. For items of work which Unit Prices are established in the contract, the quantity of work will be measured, estimated, or based on plan quantity. The determination of quantities of work performed under the contract will be made by the Engineer with the assistance of the contractor and will be based on lines and grades shown on the plans and as given during the progress of work or as evidenced by approved tickets for weight or liquid measure or by measurements made or approved by the engineer. The contractor will be paid based on the actual quantity of work completed and accepted.

B. Items of Work and Construction Details

1. Items of work to be performed in conformance with this specification and the construction details therefore are:
 - a. Bid item 12, CONCRETE GROUT FOR RIP RAP
 - (1) This item shall consist of furnishing and placing concrete grout on those portions of the riprap shown on the drawings.
 - (2) The grout shall be consolidated into the voids with the use of a concrete vibrator. The average rate of grout application shall be adjusted to ensure that the voids are properly filled through the entire riprap depth. A smooth surface is NOT to be created by the grouting operation.
 - (3) Grouting operation shall not be performed except in the presence of the Engineer or Engineer's representative.
 - (4) Measurement and payment for concrete grout shall be on a cubic yard basis measured to the nearest 0.1 cubic yard. Provide tickets to engineer.
 - (5) Grout shall be procured from a redi-mix plant and placed using a concrete pump. Provide mix design to the engineer for approval.
 - (6) Grout shall be placed in contact with the downstream sheet pile over the full depth of riprap. There shall be no voids against the sheet pile.



**Construction Specification
000 IA-81 Metal Fabrication and Installation**

1. SCOPE

The work shall consist of furnishing, fabricating, and installing metalwork including metal parts of composite structures.

2. MATERIALS

Steel shall be of structural quality. Finished surfaces shall be smooth and true to assure proper fit. Bolts, nuts, washers, rods, rivets, etc., shall be of a material equal to the steel being fastened.

3. PROTECTIVE COATINGS

Protective coatings will consist of either galvanizing or painting and shall be applied by the fabricator.

Galvanizing shall consist of a zinc coating by the hot dip process, except that bolts, nuts, and washers may have a electrodeposited zinc coating.

Paint System for this specification shall consist of the application of one coat of Epoxy Polyamide Primer (lead and chromate free) and one or more coats of Epoxy Polyamide (intermediate or finish), lead free. When finished, it will have a minimum dry film thickness of 8.0 mils.

4. FABRICATION

Materials shall be carefully fabricated as shown on the drawings. The fabrication shall be smooth and true to assure proper fit. Galvanized items shall not be cut, welded, or drilled after the zinc coating is applied.

5. ERECTION

The metal shall be erected true and plumb, closely conforming to the drawings.

Specific Site Requirements

A. Measurement and Payment

1. Compensation for any work item described in the contract documents but not listed in the bid schedule will be included in the payment for the item of work to which it is made subsidiary. Such items and bid items to which they are made subsidiary are identified in the Items of Work and Construction Details section of the Special Specification. For any item described in the bid documents, not included in any bid item, or not made subsidiary to any bid item in the Items of Work, shall be made subsidiary to the Mobilization bid item.

2. Quantities used for progress payments shall be considered as only approximate and provisional and shall be subject to recalculation, adjustment, and correction by the engineer in subsequent payment applications. Inclusion of any quantities in a progress payment, or failure to disapprove the work at the time of any progress payment, shall not be construed as acceptance of the corresponding work or materials.

B. Items of Work and Construction Details

1. Items of work to be performed in accordance with this specification and the construction details therefore are:
 - (a) Subsidiary Items, Steel
 - (1) This item will consist of furnishing and installing the steel channel pieces used to form the crest of the sheet pile weir (waler), reinforcing, and steel used for fabrication of the stoplog channel, and steel grating used in covering the water control structure.
 - (2) No separate payment will be made for Steel. Payment for this item will be considered subsidiary to Bid Item 10 and 13.
 - (b) Subsidiary Items, Aluminum
 - (1) This item will consist of furnishing and installing the aluminum stop logs used in the water control structure.
 - (2) No separate payment will be made for Aluminum. Payment for this item will be considered subsidiary to Bid Item 13.

Construction Specification 000 IA-92 Fences

1. SCOPE

The work shall consist of furnishing and installing fences, including gates and fittings.

2. STANDARD FENCE

Barbed wire fences shall have a minimum of 4 wires for farm borders. A minimum of three wires shall be used for interior fencing, cross fencing, or excluding livestock from special areas such as wildlife area, forested tracts or other special use areas. Wires shall be spaced approximately an equal distance apart. The top wire shall be at least 42 inches high and 2 inches below the top on wood posts and 1 inch below the top on steel posts. The bottom wire shall be 18 inches or less above the ground level. Wire shall be spaced no more than 12 inches apart.

Each barbed wire shall consist of 2 twisted strands of either 12 ½ gauge wire or 15 ½ gauge high tensile strength wire. The barbs shall be either 2-point barbs on approximately 4 inch centers or 4-point barbs on approximately 5 inch centers. Wire shall be stretched and attached after the posts are properly set and backfilled. Attach wire to the side of the post closest to the livestock, except on corners and curves where the wire should be placed on the outside of the corner or curve.

Top and bottom strands of woven wire shall be a minimum of 12 ½ gauge. Wire for intermediate strands shall be 14 1/3 gauge or heavier. Fences with woven wire 32 inches or less in height shall have at least 2 barbed wires above the woven wire spaced 8 to 12 inches apart. Fences constructed with woven wire higher than 32 inches shall have at least 1 barbed wire 8 to 12 inches above the woven wire. The base of the woven wire shall be placed near the ground surface. The top wire shall be at least 42 inches above the ground level and 2 inches below the top of wood posts and 1 inch below the top of steel posts. All wire shall be galvanized. . Wire shall be stretched and attached after the posts are properly set and backfilled. Attach wire to the side of the post closest to the livestock, except on corners and curves where the wire should be placed on the outside of the corner or curve.

Staples shall be 9 gauge steel or heavier with a minimum length of 1 ½ inches for soft woods and a minimum length of 1 inch for close grained hardwoods. Drive staples diagonal to the grain of the wood and at a slight downward angle. Space should be left between the staple and the post to permit free movement of the wire. Wires may be attached to steel posts by use of manufacturer's clips or by 14 gauge galvanized wire twisted at least two turns.

All wooden posts (except red cedar, Osage orange, or black locust) shall be treated with pentachlorophenol, creosote, or chromated copper arsenate (CCA) by a method that ensures complete penetration of the sapwood. At least half of the diameter of red cedar shall be heartwood. Quality of treated wood shall provide sufficient strength and quality to last for the expected life of the fence.

All corner posts, gate posts, end posts, pull posts and brace posts normally shall be wood with sufficient length for the construction of at least a 42 inch high fence and permit setting the post at least 36 inches deep. Earth backfill shall be thoroughly tamped. On areas where soil depth is restricted to less than 36 inches, additional anchors or deadman applied against the direction of pull may be needed. Wood posts shall have a minimum top diameter of 5 inches. A 2-½ inch steel pipe with appropriate bracing or set in concrete of sufficient depth also may be used. Reinforced concrete or metal posts of equivalent strength may be substituted if they have suitable means of attaching wires and braces.

The maximum spacing of line posts shall be one rod (16.5 feet). Wood line posts shall have a 3 inch top (2 ½ inch for Osage orange). Wood line posts shall have a minimum length of 6 ½ feet and shall be set or driven to a minimum depth of 24 inches where conditions permit. When posts are set, earth backfill shall be thoroughly tamped. Steel line posts shall weigh not less than 1.33 pounds per foot and shall have a steel anchor plate securely fastened to the plate. The posts shall be "T", "U", or "Y" shaped and have corrugations, knobs, studs, or grooves suitable for fastening fencing to the posts. Steel posts shall be rolled from high carbon steel and shall have a protective coating; either galvanized by the hot dip process, painted with one or more coats of high grade weather resistant paint for steel, or enameled and baked. Steel line posts shall be at least 6 feet in length and shall be set in the ground a minimum of 20 inches. Steel posts shall be used as line posts at least once every 6 rods (99 feet) to act as a ground for lightning protection.

End bracing will be installed at locations where the fence ends and on both sides of gate openings. Corner bracing should be installed where fence alignment changes 15 degrees or more. Bracing is required at all corner, gate, pull and end assemblies in a fence. The brace member shall be the equivalent of a wood post with at least a 3 ½ inch diameter at the top or standard weight 2 inch diameter galvanized steel pipe. The brace shall be at least 3 feet above the ground and at least 8 inches below the top of the post. The brace member shall be 6 to 8 feet in length. A brace wire consisting of 2 complete loops of 9 gauge smooth wire, 2 loops of barbed wire or a single loop of 12 ½ gauge high tensile strength wire shall be installed. "H" braces or angle braces as shown in figure 3 will be used in standard fences.

Pull post assemblies consisting of three posts with braces shall be installed in straight reaches of fence at intervals 660 feet (40 rods), at any point where the vertical angle described by two adjacent reaches of wire is upward and exceeds 10 percent and at the beginning and end of each curve.

For a narrow ditch or draw crossing with slopes steeper than 8 feet horizontal to 1 foot vertical, the fence shall be anchored with a concrete anchor weighing at least 150 pounds and buried with at least 18 inches of cover or a commercial screw-in type metal anchor 5 inches in diameter and not less than 48" long to position the fence to the contour of the ditch or draw.

Wire gates shall be made of the same materials as used for the fence. Panel or tube type gates shall be equivalent in quality to the fencing material and shall be fitted with at least two hinges and a latch or galvanized chain for fastening.

3. CHAIN LINK FENCE

Chain link fence, fabric, posts, top rails, braces, gates and accessories shall conform to the requirements of ASTM Specifications types, classes and materials listed below. The fence shall be constructed in a workmanlike manner.

Fabric shall be ASTM A392, 2-inch mesh, 9 gauge galvanized steel wire. Zinc coating shall be Class 2. Fabric shall be 60 inches in height. Fabric shall not be stretched until at least 4 days after the posts are set in concrete backfill or grouted in concrete walls. A stretcher bar of the same length as the fabric width shall secure each end of each run of fabric. The bar and fabric shall be stretched taut and secured to the end post by tension bands equally spaced not more than 15 inches apart. The fabric shall be attached to all braces; the top rail, all line posts and the tension wire by wire ties or clips at intervals not exceeding two feet.

Posts and fence framework shall conform to the requirements of ASTM F1043 Group 1A, for Heavy Industrial Fence. Coatings shall be type A galvanized coating both internal and external surfaces. Steel pipe for posts shall conform to the requirements of ASTM F1043 and F1083. The minimum diameter of end, corner, and pull posts shall be 2 3/8 inches. Line posts shall be at least 1.9 inches in diameter. Gate posts shall have a minimum diameter of 2 7/8 inches. The maximum spacing of line posts shall be ten feet. Post holes shall be at least 6 inches in diameter and 18 inches deep for line posts and 24 inches for corner, end, pull and gate posts. All posts shall be set in concrete backfill. Concrete shall completely fill the annular space around the posts and shall be neatly finished to slope up to the post approximately 1 ½ inches above the ground surface. Pull posts shall be located in long straight runs of fence at intervals of 500 feet or less. Posts set in concrete walls shall be grouted into preformed holes at least 12 inches in depth. Where posts are installed in highly corrosive soils such as disturbed mine spoil, the posts shall be vinyl coated in addition to the above requirements and set in concrete poured inside a 6 inch clay tile or plastic tubing at least 24 inches long.

When used, braces and top rails shall be installed horizontally at the height shown on the drawings or recommended by the manufacturer. See previous paragraph for specifications. Braces and top rails shall be attached to the posts by suitable fittings, as recommended by the manufacturer. When the brace has been placed, a 6 gauge double truss galvanized steel wire with adjustable tightener and fittings shall be attached to the corner post just below the brace and to the brace post approximately 4 inches above ground level. A similar truss wire shall be attached to brace post just below the brace and to the corner post approximately 4 inches above ground level. A 7 gauge galvanized steel tension wire, tightened by mechanical means, shall be placed approximately 4 inches from the ground level. A similar tension wire shall be placed at the top of the fence if a top rail is not used.

Gates, gateposts and gate accessories shall conform to the requirements of ASTM F900. Coating shall be the same as the adjoining fence and framework.

4. HIGH TENSILE WIRE (HTW) FENCE

HTW fence shall have a minimum of eight smooth strands of galvanized 12 ½ gauge wire with not less than 0.8 ounce of zinc per square foot of wire surface and a tensile strength of 200,000 pounds per square inch. Each strand of wire shall be strung to a tension of not less than 250 pounds. The top wire shall be 48 to 54 inches above the ground surface. The bottom wire shall not be more than 6 inches above the ground surface. The wire shall be fastened on a direct line splice with enough nicopress sleeves that the accumulated strength of the sleeves exceeds the tensile strength of the wire. End wrap splices shall be fastened with two nicopress sleeves. Splices may also be made with other products used as directed by the manufacturer.

Posts shall be the same size and material as posts for standard fences. Line posts shall be spaced not more than 30 feet apart with spacer made of wood or fiberglass spaced at not more than 15 feet from either post. Corners, pull assemblies, ends and gates shall have a double assembly consisting of three driven posts with horizontal braces. Each assembly shall be further braced with a double wrap of high tensile wire (see attachment A).

5. PERMANENT HTW ELECTRIC FENCE

Permanent HTW electric fences are constructed with the intent of being in place for years. It is the equivalent of any non-electric permanent fence. Electric fences provide psychological deterrent rather than a physical barrier to livestock and wildlife. To be effective, a shock of at least 1,000 volts must be delivered to cattle, 2,000 volts to sheep and 2,500-3,000 volts to deer, dogs, and coyotes.

Wire shall be a single strand of 12 ½ gauge or larger with a minimum tensile strength of 110,000 pounds per square inch. The wire shall galvanized (Type III) or aluminum or copper clad. Barbed wire should not be used on electric fences because of safety hazard. Wire will be attached to the posts by a method that allows them to slip. Wires will be attached to stays in a manner that prevents stay slippage along the fence. The tension of each wire shall be sufficient to maintain the wires at the appropriate height. Suggested wire heights and spacing are shown by intended use in the following table:

Fence Description	Number of Wires	Wire Height (In.)
Internal/Cross Fence		
Cow /calf & stocker	1 wire	30 to 34
Hogs	1 wire	12
Cow /calf & stocker	2 wire	22;32
Sheep and cattle	3 wire	10; 20; 32
Sheep and cattle	4 wire	10; 20;32;46
Perimeter Fence		
Cattle, horses, sheep (Non-predator)	5 wire	10; 20; 30; 40; 50
Sheep, goats (Predator)	8 wire	4; 8; 12; 18; 24; 30; 40; 52

Electronic energizers of power fence controllers shall be installed according to manufacturer's recommendations. The energizers shall be high power, low impedance with 5,000 volt peak output and a pulse that is less than 300 mAmps in intensity, finished within 0.0003 of a second and at a rate of 35-65 pulses per minute. Energizers shall be provided with high impact, weather resistant cases. Circuitry shall be solid state. Service modules shall be snap-in for fast field repair. A safety fuse to prevent over pulsing shall be provided. The system shall be 110 volt, 220 volt or 12-volt battery powered. The battery-powered system shall be capable of working for at least 3 weeks without replacing the battery. If the length of the fence requires more than 4 joules (watts times seconds equals joules), a solar charger will be needed for 12 volt systems. The energizer shall be capable of producing one joule for each mile of planned fence when average energy loss is expected.

All electric fences must be properly grounded. The energizer ground wire should be connected to a galvanized pipe or rod ½ inch or larger in diameter. Bury 3 feet of ground rod for each joule of energy output. Ground rods should be buried where soil remains moist for best results. Ground rods should be driven into the ground at least 10 feet apart when multiple rods are necessary to provide the required length of ground rod. Normally individual ground rods will be driven no more than 6 to 8 feet into the ground. Connect a continuous ground wire from the energizer to each ground rod with aluminum or galvanized steel clamp. If energizer terminals are not stainless steel or copper, do not use copper ground rods due to corrosion at the connection and subsequent loss of electrical continuity. Copper rods with copper wire may be used if energizer terminals are stainless steel or copper. Use copper clamps with copper wire and copper rods.

The ground wire(s) of the fence may be connected to the same ground as the energizer or to a separate ground with the same size and depth requirements. More ground rods may be needed for the system to function properly. Do not use the grounding system for other existing applications, such as power poles, breaker boxes and milk barns,. At least 25 feet should separate the fence grounding system from any other grounding system.

Lightening can cause damage to the energizer. Most energizers are poorly protected from damage caused by lightning. External lightning arrestors and an induction loop (lightning choke) should be installed for added protection. Lightning arrestor grounding rods should be placed at least 65 feet from those of the energizer (See attachment B).

Install an additional set of ground rods and attach to a lightning arrestor. The lightning arrestor ground must be better than the energizer ground for it to function properly, because lightning will seek the path of least resistance to ground. Use at least 1 more ground rod on the arrestor than was used on the energizer. Attach the lightning arrestor to the wires of the fence. Install a lightning choke in the fence line immediately between the lightning arrestor and the energizer.

For protection of energizers, it is recommended that for 120 or 240-volt energizers that a voltage spike protector be used. Also, a ground rod should be installed at electric company's transformer pole (primary ground) and another ground rod installed at the electrical circuit breaker box (secondary ground), if they do not exist. Additionally, a surge protector should be installed between the energizer and power supply.

Insulation used for positive charged wire(s) must be high-density polyethylene with ultra-violet stabilizer or high-density polypropylene with ultra-violet stabilizer.

Braces and end assemblies are required at all corners, gates and angles in the fence line (See attachment A for criteria on corners, angles, and brace assemblies.)

For 1 and 2 wire fences, corner, gate, end and brace assemblies use one of the following:

- Steel "T" post that are a minimum of 1.25 pounds per foot of length, with appropriate knee, deadman, angle or H-brace.
- Wood posts with a minimum top diameter of 3.5 inches set two feet in the ground with appropriate knee, deadman, angle, or H-brace.
- Wood, steel pipe or fiberglass post with a minimum top diameter of 5 inches, set to a depth equal to, or greater than, the height of the post above the ground without bracing.
- Steel pipe or fiberglass posts with a minimum diameter of 2 inches, set 2 feet in the ground with appropriate knee, angle, or H-brace, deadman or anchor plate.
- Steel pipe or fiberglass posts with a minimum diameter of 2 inches and set in concrete to a depth of 2 feet.
- Steel pipe or fiberglass posts with a minimum diameter of 1 inch with appropriate angle bracing and sufficient ground anchoring to maintain wire tension while remaining erect and firmly anchored.

For 3 or more wire power fences; corner, gate, end and brace assemblies will be either a floating angle brace or H-brace assembly. Posts will be 4-inch nominal wood, 2-inch nominal steel pipe (capped), 2-inch fiberglass or steel "T" posts with appropriate appurtenances for corner and end bracing. Posts must be set a minimum of 2 feet in the ground.

All wood posts shall be at least 2 inches higher than the top wire of the fence. Posts of any other material shall be at least 1 inch higher than the top wire of the fence.

Line post and stays will be either:

- Australian ironwood (eucalyptus) at least 2 inches in diameter; fiberglass, rigid plastic and PVC solid round sucker rod of at least 5/8 inch diameter, or fiberglass "T" post and stays of at least 1 inch in cross-section. Attach wire to the post with loose wire clips or run the wire through holes in the post. Attach the wire to stays with tight clips.
- Wood posts at least 3 inches in diameter of black locust, red cedar, Osage orange, redwood, pressure treated pine or any other wood of equal life and strength may be used. At least one half of the diameter of the red cedar and redwood post shall be heartwood. Pressure treated posts shall be treated with pentachlorophenol, creosote, or chromated copper arsenate (CCA) by a method which ensures the complete penetration of the sapwood. Insulators shall attach wire.
- Steel "U" or "T" posts that are a minimum of 1.25 pounds per foot of length. Wire shall be attached with insulators.

Posts for one or two wire fences shall be long enough to be set at least 18 inches in the ground, except that in soils which are sandy loam or coarser in texture, the posts shall be set at least 24 inches into the ground. Posts for 3 or more wire fences shall be set at least 24 inches into the ground. Posts in dips shall be constructed so that they do not pull out of the soil. Posts 2 inch or smaller shall be anchored. Wood posts shall be set to a depth sufficient to resist pull out.

Wood posts shall be at least 2 inches higher than the top wire on the fence. All other posts shall be at least 1 inch higher than the top wire of the fence.

Spacing of the line posts and stays depends on the terrain and the number of wires. Maximum spacing is as follows

- One or two wire fences may have line posts spaced up to 100 feet apart with no stays. Line posts may be spaced 150 feet apart with stays every 50 feet between the posts
- For three and four wire fences, the line posts may be spaced every 50 feet with no stays or every 150 feet with stays at spacing of not more than every 50 feet.
- Fences with more than 4 wires shall have posts and stays spaced every 30 feet, with posts not further apart than every 90 feet.
- In undulating terrain, space posts and stays as needed to maintain the fence height.

Insulators for conductive material posts, end, corner and angle braces shall be high-density polyethylene with ultra-violet stabilizer, high density polypropylene with ultra-violet stabilizer, or porcelain. All insulators shall be capable of withstanding 10,000 volts or more of current leakage. Red insulators attract hummingbirds and should not be used.

Electrified gates may be constructed of a single straight wire, galvanized cable, or polytape with a insulated spring loaded handle or an expandable, coiled, high tensile, 12 ½ gauge wire attached to an insulated handle. The number of wires shall be determined by the objective of the fence. The gate shall be constructed so that it is non-electrified when the gate is open. Overhead or underground transmission lines will be used to carry electricity past the gate to the remainder of the fence.

Use insulated galvanized wire for crossing gates and areas where an electrical shock to livestock and humans is undesirable. All underground wires must be insulated for a minimum of 15,000 volts.

Insulated underground wire should be specifically designed for high voltage electric fence. The insulation shall be high-density polyethylene with ultra-violet stabilizer or high-density polypropylene with ultra-violet stabilizer. Placing buried wire inside plastic pipe helps to decrease the likelihood of short-circuiting. Overhead transmission lines shall be at a height where the lines do not impeded movement of livestock or equipment.

An electrified floodgate may be used in lieu of a non-electrified gate if desired. The electrified floodgate should be constructed by stretching an electrified wire across the drainage above the high water level. Attach droppers of 12 ½ gauge high tensile fence wire, galvanized cable or galvanized chains to the electrified wire at a spacing of 6 inches for sheep and 12 inches for cattle. The droppers shall be extended to approximately 6 inches above normal water level. Connect gate to electric fence with a double insulated cable through a cutoff switch and flood control gate controller. If flooding is expected to last for an extended period of time, switch the floodgate off. (See attachment C).

Other materials of equivalent strength, durability and design may be used.

6. TEMPORARY ELECTRIC FENCE

Temporary electric fencing is constructed with the intent of being left in place for only a short period of time. The fence is not intended as a substitute or equivalent of permanent fence. The temporary fence requires materials, design and construction that will accomplish the intended purpose and last for the planned time period with no more maintenance than is desired.

Many companies market portable fence systems that use materials such as polyethylene wire and tape with steel or aluminum wire woven into them, aluminum wire, plastic and fiberglass posts, reels to roll up wire, and battery operated energizers that are high voltage and low impedance (see previous section on energizers). A minimum of six strands of steel or aluminum wire should be woven into the polywire or polytape. Temporary fences may be attached to permanent fences to subdivide pasture. Follow manufacturer's directions for construction, use and operation of temporary electric fences

Specific Site Requirements

A. Measurement and Payment

1. Compensation for any work item described in the contract documents but not listed in the bid schedule will be included in the payment for the item of work to which it is made subsidiary. Such items and bid items to which they are made subsidiary are identified in the Items of Work and Construction Details section of the Special Specification. For any item described in the bid documents, not included in any bid item, or not made subsidiary to any bid item in the Items of Work, shall be made subsidiary to the Mobilization bid item.
2. Quantities used for progress payments shall be considered as only approximate and provisional and shall be subject to recalculation, adjustment, and correction by the engineer in subsequent payment applications. Inclusion of any quantities in a progress payment, or failure to disapprove the work at the time of any progress payment, shall not be construed as acceptance of the corresponding work

B. Items of Work and Construction Details

1. Items of work to be performed in accordance with this specification and the construction details therefore are:
 - (a) Subsidiary Items, Fencing
 - (1) Contractor is responsible for repair and replacement of any fence damages or removed and designated to remain. Replacement shall be of the same type and construction methods as the existing fences.
 - (2) No separate payment will be made for fencing. This item is subsidiary to Bid Item 5.

Attachment A

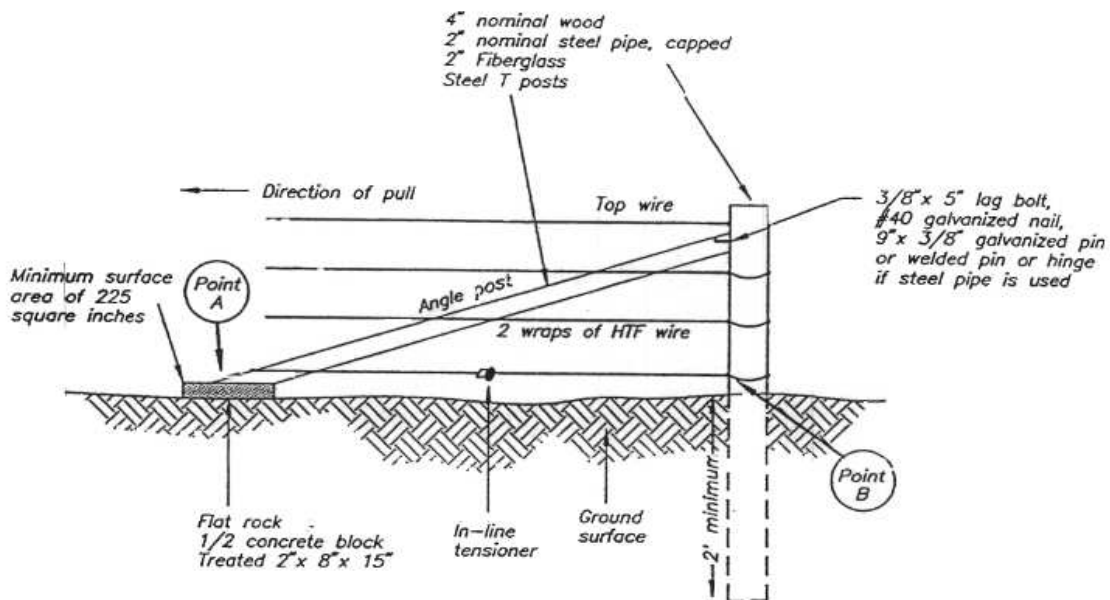

Note:
 Distance from point A to B shall be a minimum twice the height between the top wire and the ground surface.

Single Post End Brace (Floating Angle Brace) Assembly

Figure 1

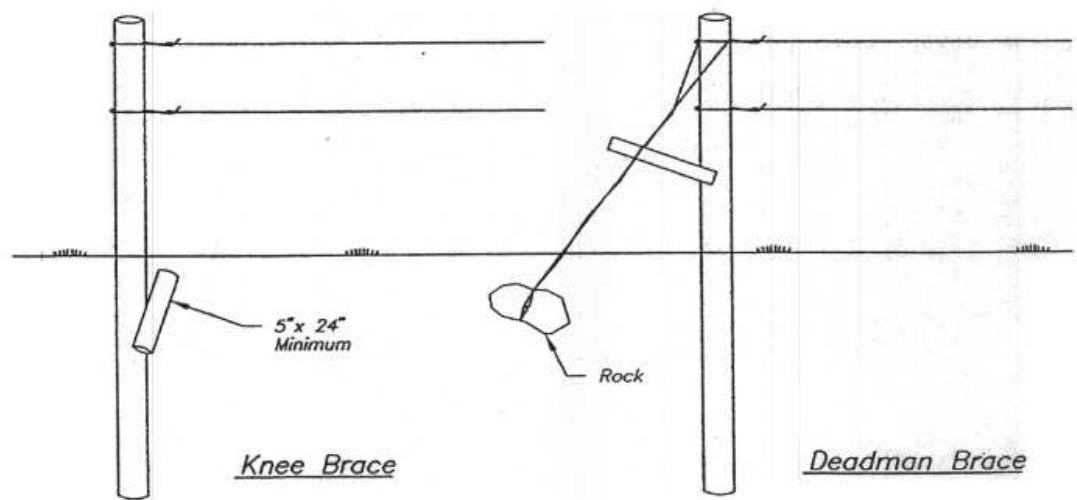
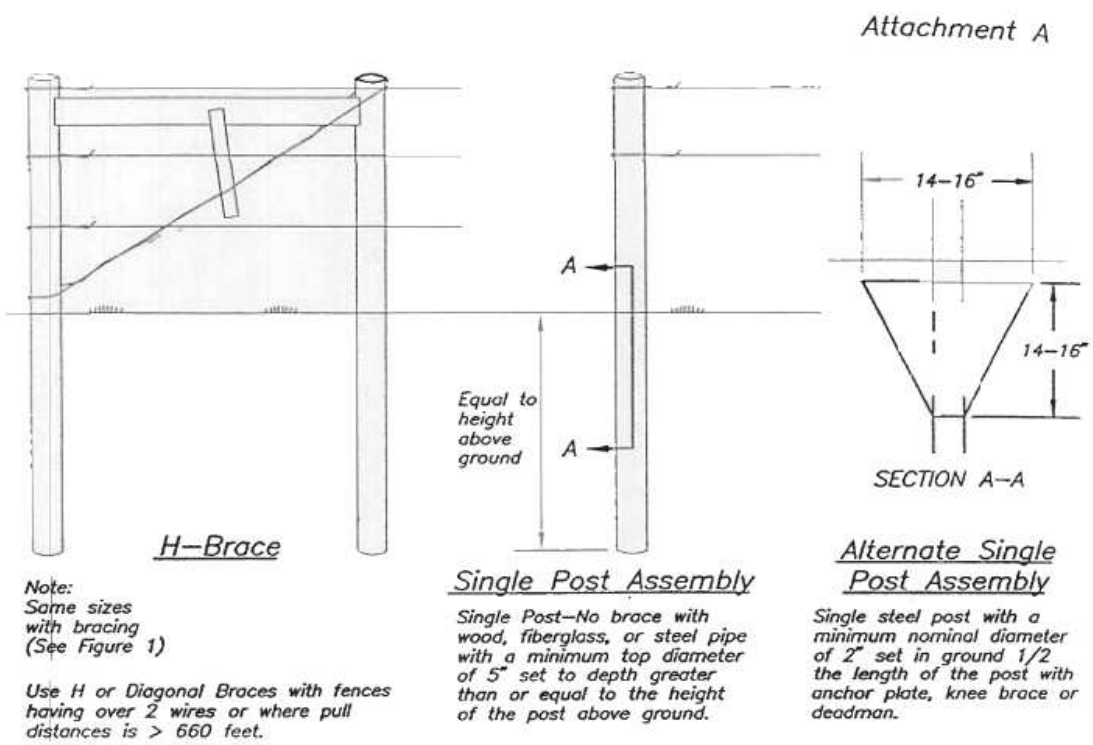

Knee or Deadman Braces may be used on fences with 2 wires or where pull distances is < 660 feet.

Electric Fencing Bracing Alternatives

Figure 2

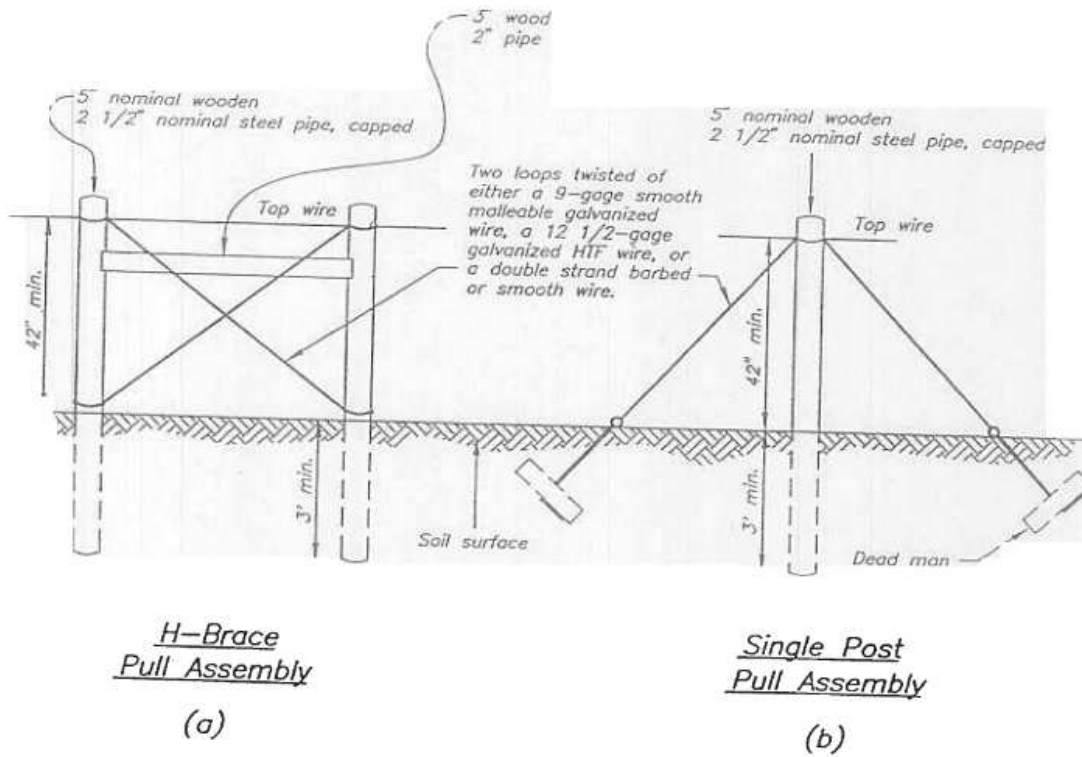

Standard Suspension Fence,
Corner and Pull Assembly

Figure 3

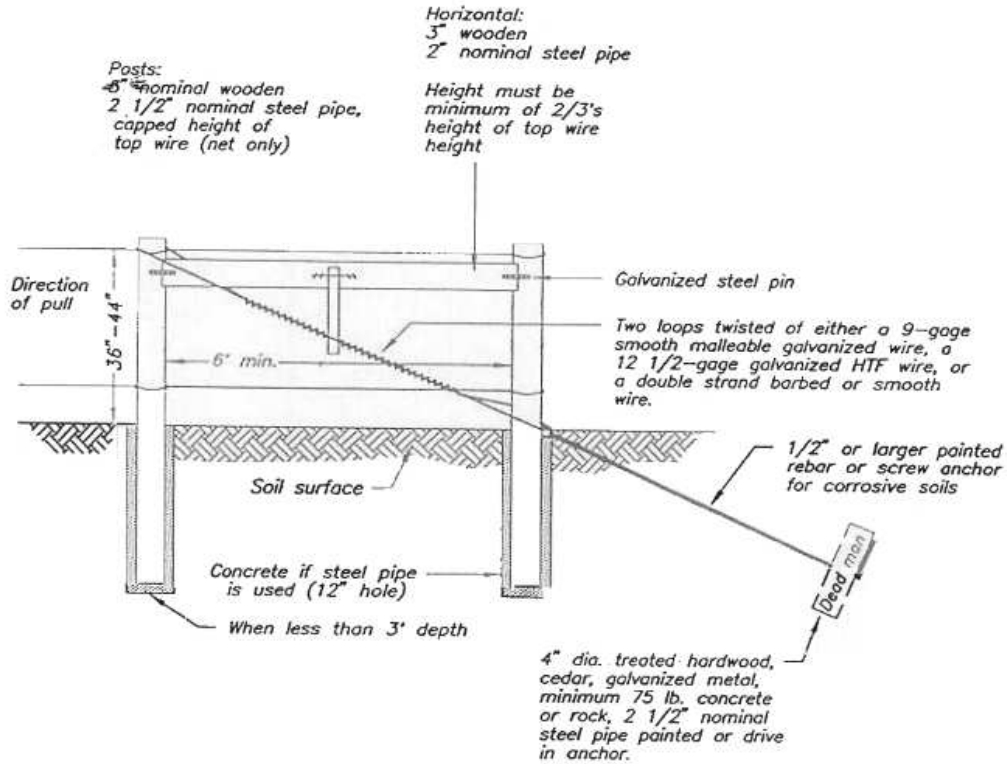

Materials: Post must be new eastern red juniper, blueberry juniper, bois-d'arc, treated pine, treated hardwood, or steel pipe (cemented). Used steel pipe is acceptable and must be painted.

Splices: Use "western-union splices, figure "8" knots or crimping sleeves for malleable wire.
Use crimping sleeves or figure "8" knot for high tensile strength wire.

2 Post Brace With Deadman

(c)

Standard Suspension Fence,
Corner and Pull Assembly

Figure 3

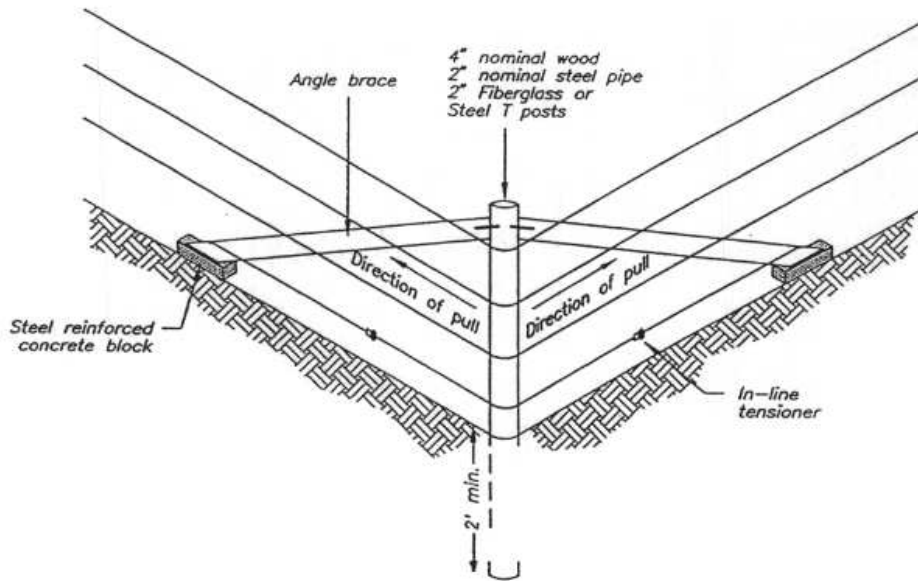

Single Post Corner or Angle Brace Assembly

(d)

Standard Suspension Fence,
Corner and Pull Assembly

Figure 3

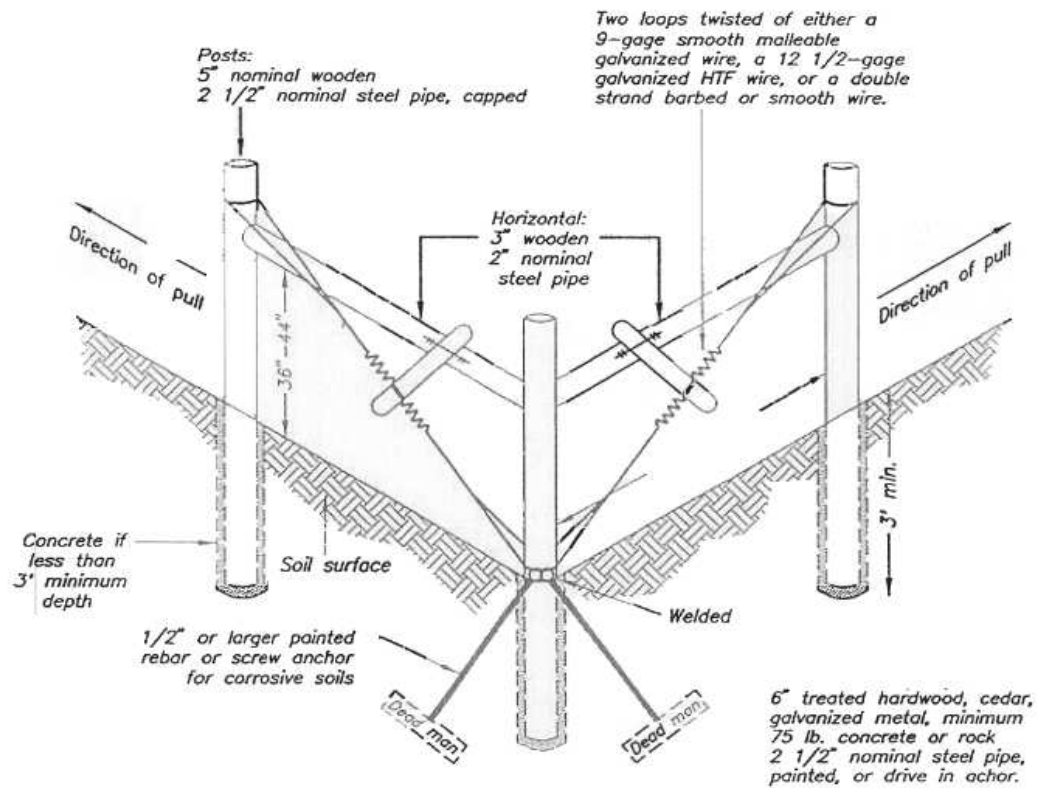

Materials: Post must be new eastern red juniper, blueberry juniper, bois-d'arc, treated pine, treated hardwood, or steel pipe. Used steel pipe is acceptable and must be painted.

Splices: Use "western-union splices, figure "6" knots or crimping sleeves for malleable wire.

Use crimping sleeves or figure "8" knot for high tensile strength wire.

Deadmaned 3-Post Corner

Figure 4

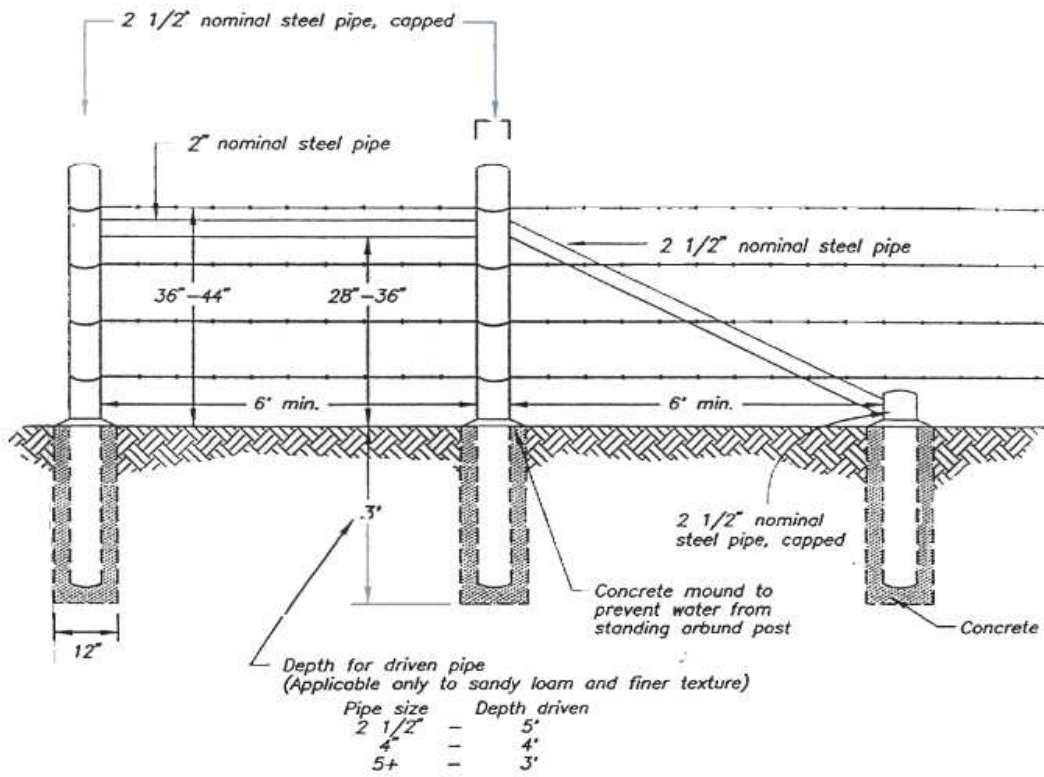

Welded Steel 3-Post Diagonal
End Brace Assembly

Figure 5

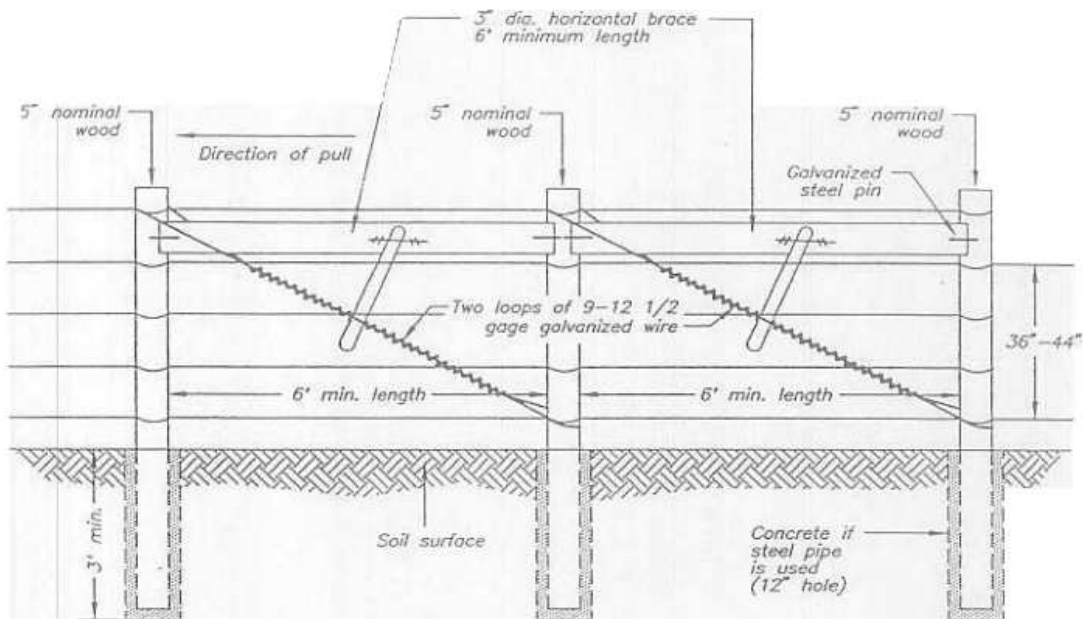

Note:
Materials shown above may be substituted using 2 1/2" nominal steel pipe, capped, set in concrete (12 in. diameter hole). Pipe must be painted.

Wooden 3 Post Double "H" Brace
End Assembly Without Deadman

Figure 6

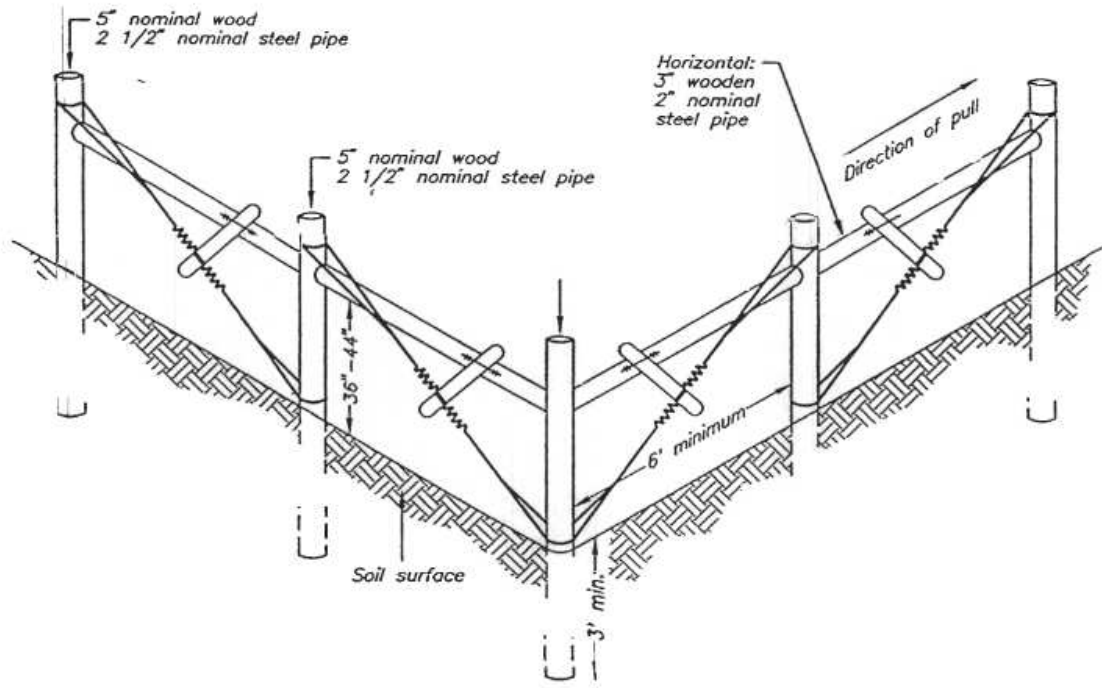

Without Deadman

Figure 7

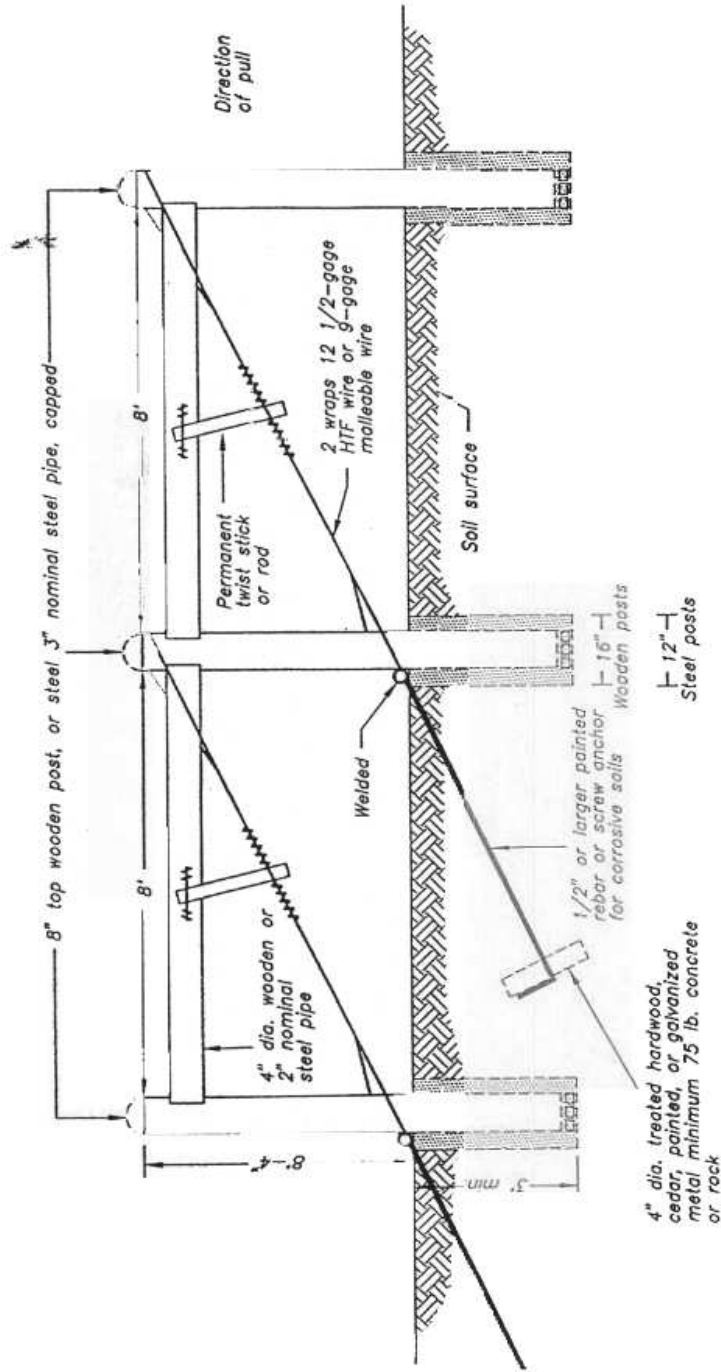

Deadman is optional except where surface of soil is more than 20 inches in depth of loamy fine sand or coarser.

End Brace Assembly Deer Management Fence

Figure 8

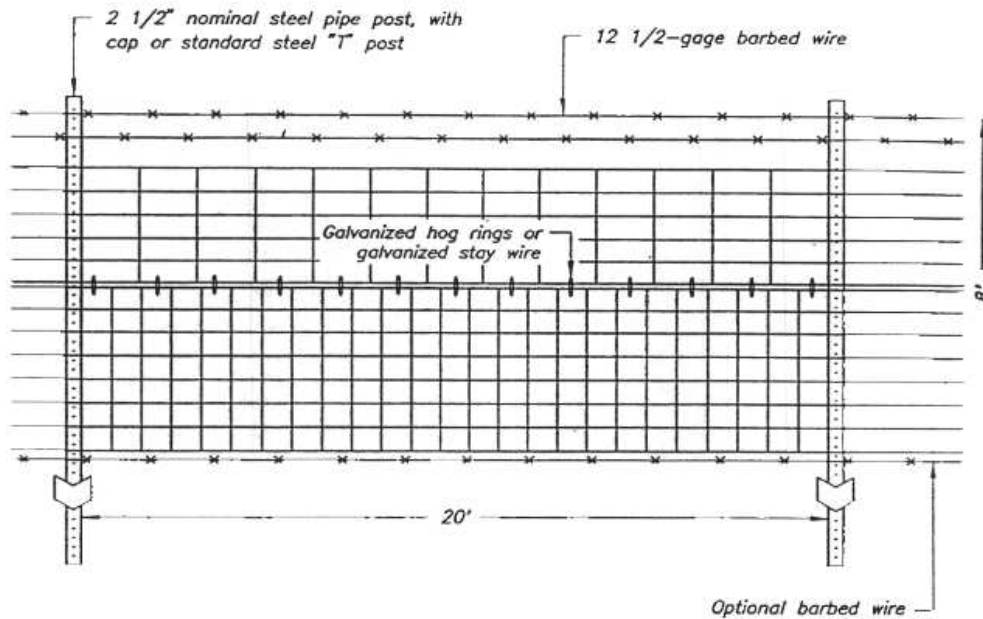

Note: If standard steel "T" posts are used, install 2 1/2" nominal steel pipe post, with cap or 6" top wooden post every 150' (Wooden stays may be placed between line post as needed).

General Installation Specification For Deer Management Fence

Figure 9

Attachment B

Methods of tying HTS Wire

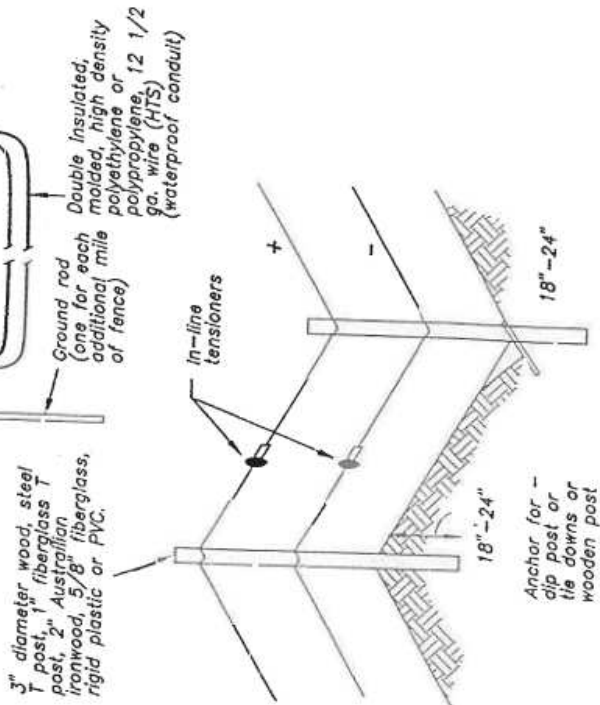
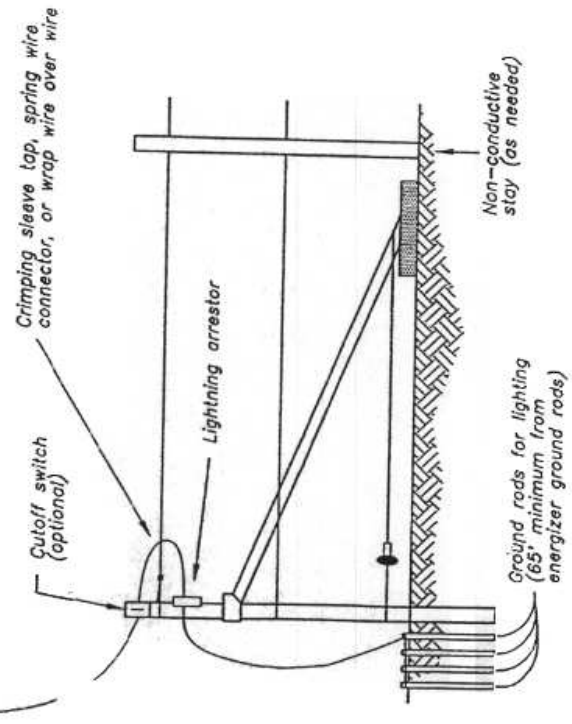
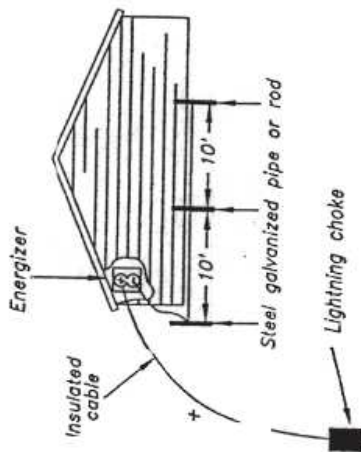
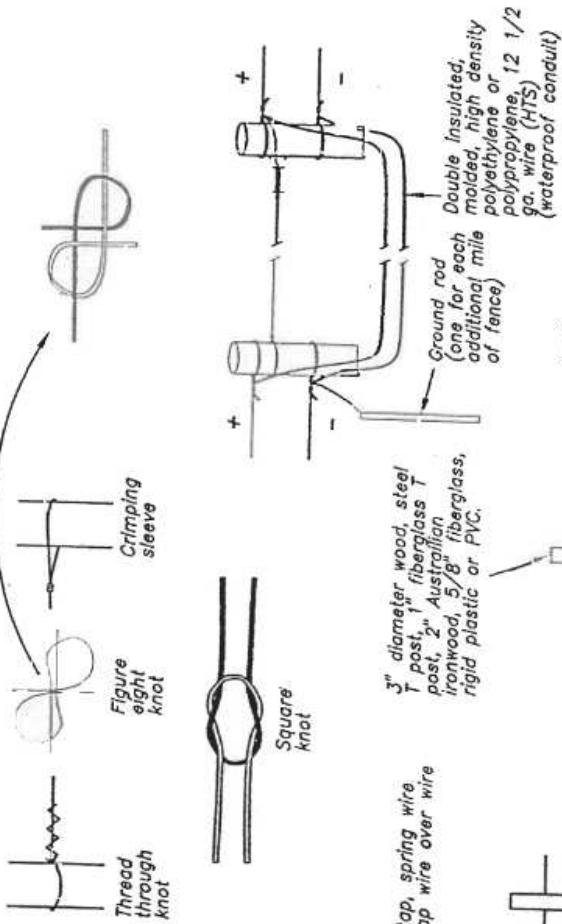

F.

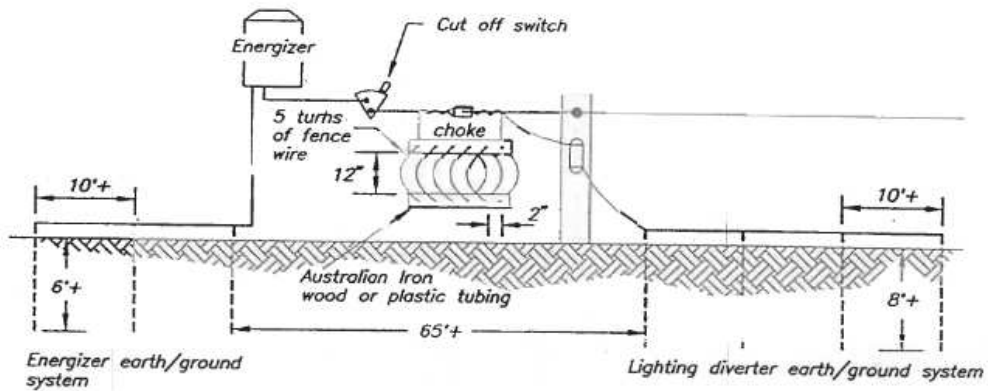

An induction loop may be as an alternative to a choke.

An induction loop is made by coiling 8 to 10 loops of heavily insulated 12 gage wire in 10-12" diameter circles and taping the loops together.

Electric Fence

Figure 2

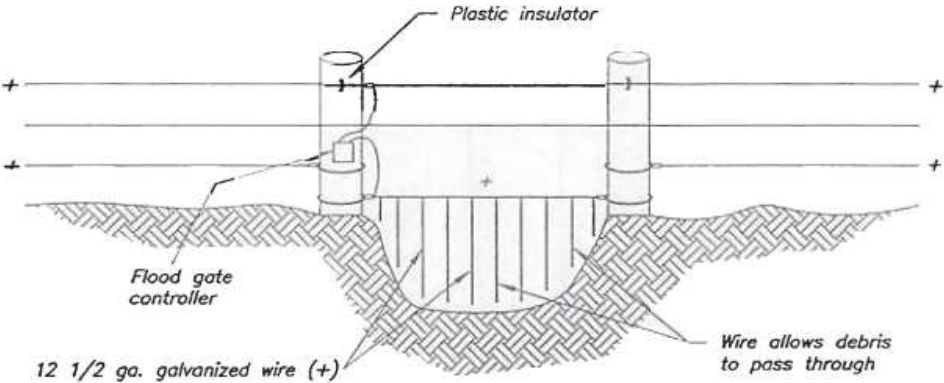

Electric Flood Gate

Figure 1

**Construction Specification
000 IA-95 Geotextile**

1. SCOPE

This work shall consist of furnishing all materials, equipment, and labor necessary for the installation of geotextile.

2. MATERIAL QUALITY

Geotextile shall be manufactured from synthetic long chain or continuous polymeric filaments or yarns, having a composition of at least 95 percent, by weight, of polypropylene, polyester or polyvinylidene-chloride. The geotextile shall be formed into a stable network of filaments or yarns that retain their relative position to each other, are inert to commonly encountered chemicals and are resistant to ultraviolet light, heat, hydrocarbons, mildew, rodents and insects. Unless otherwise specified, the class and type of geotextile shall be as shown on the drawings and shall meet the requirements for materials that follow:

1. Woven Geotextile shall conform to the physical properties listed in Table 1. The woven geotextile shall be manufactured from monofilament yarns that are woven into a uniform pattern with distinct and measurable openings. The geotextile shall be manufactured so that the yarns will retain their relative position with regard to each other. The yarns shall contain stabilizers and/or inhibitors to enhance their resistance to ultraviolet light or heat exposure. The edges of the material shall be salvaged or otherwise finished to prevent the outer yarn from unraveling.
2. Nonwoven Geotextile shall conform to the physical properties listed in Table 2. Nonwoven geotextile shall be manufactured from randomly oriented fibers that have been mechanically bonded together by the needle-punched process. In addition, one side may be slightly heat bonded. Thermally bonded, nonwoven geotextile, in addition to mechanically bonded, nonwoven geotextile, may be used for Road Stabilization. The filaments shall contain stabilizers and/or inhibitors to enhance their resistance to ultraviolet light or heat exposure.
3. The geotextile shall be shipped in rolls wrapped with a protective covering to keep out mud, dirt, dust, debris and direct sunlight. Each roll of geotextile shall be clearly marked to identify the brand, type and production run.

3. STORAGE

Prior to use, the geotextile shall be stored in a clean dry place, out of direct sunlight, not subject to extremes of either hot or cold, and with the manufacturer's protective cover in place. Receiving, storage, and handling at the job site shall be in accordance with the requirements in ASTM D 4873.

4. SURFACE PREPARATION

The surface on which the geotextile is to be placed shall be graded to the neat lines and grades as shown on the drawings. The surface shall be reasonably smooth and free of loose rock and clods, holes, depressions, projections, muddy conditions and standing or flowing water (unless otherwise shown on the drawings).

5. PLACEMENT

Prior to placement of the geotextile, the soil surface will be inspected for quality assurance of design and construction. The geotextile shall be placed on the approved prepared surface at the locations and in accordance with the details shown on the drawings. The geotextile shall be unrolled along the placement area and loosely laid (not stretched) in such a manner that it will conform to the surface irregularities when material is placed on or against it. The geotextile may be folded and overlapped to permit proper placement in the designated area.

The geotextile shall be joined by overlapping a minimum of 18 inches (unless otherwise specified), and secured against the underlying foundation material. Securing pins, approved and provided by the geotextile manufacturer, shall be placed along the edge of the panel or roll material to adequately hold it in place during installation. Pins shall be steel or fiberglass formed as a "U", "L", or "T" shape or contain "ears" to prevent total penetration. Steel washers shall be provided on all but the "U" shaped pins. The upstream or up-slope geotextile shall overlap the abutting down-slope geotextile. At vertical laps, securing

pins shall be inserted through both layers along a line through approximately the midpoint of the overlap. At horizontal laps and across slope laps, securing pins shall be inserted through the bottom layer only. Securing pins shall be placed along a line approximately 2 inches in from edge of the of the placed geotextile at intervals not to exceed 12 feet unless otherwise specified. Additional pins shall be installed as necessary and where appropriate, to prevent any undue slippage or movement of the geotextile. The use of securing pins will be held to the minimum necessary. Pins are to be left in place unless otherwise specified.

Should the geotextile be torn or punctured, or the overlaps disturbed, as evidenced by visible geotextile damage, subgrade pumping, intrusion, or grade distortion, the backfill around the damaged or displaced area shall be removed and restored to the original approved condition. The repair shall consist of a patch of the same type of geotextile being used, overlaying the existing geotextile. The patch shall extend a minimum of 2 feet from the edge of any damaged area.

The geotextile shall not be placed until it can be anchored and protected with the specified covering within 48 hours or protected from exposure to ultraviolet light. Geotextile shall be placed in accordance with the following applicable specification according to the use indicated in drawings:

Slope protection – Class I or II as indicated in Tables 1 and 2.

The geotextile shall not be placed until it can be anchored and protected with the specified covering within 48 hours or protected from exposure to ultraviolet light. Rock shall not be pushed or rolled over the geotextile.

Class I, unprotected – limit height for dropping stone onto bare geotextile to 3 feet.

Class II, protected – require the use of 6 inches a clean pit-run gravel over the geotextile to cushion the stone and limit the height of drop to 3 feet.

On slopes with strong seepage flow, the geotextile must be in intimate contact with the soil to prevent erosion of the soil surface. Use 6 inches of a clean pit-run gravel over the geotextile to hold it in place and minimize voids under the riprap. Embedment of the geotextile in a trench to form a cutoff at regular intervals down the slope will prevent erosion under the fabric. Place cutoffs more closely together in highly erodible soils and wider apart in more stable soils

Subsurface drains – Class III as indicated in Tables 1 and 2.

The geotextile shall not be placed until drainfill or other material can be used to provide cover within the same working day. Drainfill material shall be placed in a manner that prevents damage to the geotextile. In no case shall material be dropped on uncovered geotextile from a height of more than 5 feet.

Road stabilization – Class IV as indicated in Tables 1 and 2.

The geotextile shall be unrolled in a direction parallel to the roadway centerline in a loose manner permitting conformation to the surface irregularities when the roadway fill material is placed on its surface. In no case shall material be dropped on uncovered geotextile from a height of more than 5 feet. Unless otherwise specified, the minimum overlap of geotextile panels joined without sewing shall be 24 inches. The geotextile may be temporarily secured with pins recommended or provided by the manufacturer, but they shall be removed before the permanent covering material is placed.

Table 1. Requirements for Woven Geotextiles^{1/}

Property	Test Method	Class I	Class II	Class III	Class IV
Grab tensile strength (pounds)	ASTM D4632	247 minimum	180 minimum	180 minimum	315 minimum
Elongation at failure (%)	ASTM D4632	< 50	< 50	< 50	< 50
Trapezoidal tear strength (pounds)	ASTM D4533	90 minimum	67 minimum	67 minimum	112 minimum
Puncture strength (pounds)	ASTM D6241	495 minimum	371 minimum	371 minimum	618 minimum
Ultraviolet light (% retained strength)	ASTM D4355	50 minimum	50 minimum	50 minimum	70 minimum
Permittivity (sec ⁻¹)	ASTM D4491			as specified	
Apparent opening size (AOS) ^{2/}	ASTM D4751			as specified	
Percent open area (POA) (%)	USACE ^{3/} CWO-02215-86			as specified	

1/ All values are minimum average roll values (MARV) in the weakest principal direction, unless otherwise noted.

2/ Maximum average roll value.

3/ Note: CWO is a USACE reference.

Table 2. Requirements for Nonwoven Geotextiles^{1/}

Property	Test Method	Class I ^{2/}	Class II ^{2/}	Class III ^{2/}	Class IV ^{2/}
Grab tensile strength (pounds)	ASTM D4632 grab test	202 minimum	157 minimum	112 minimum	202 minimum
Elongation at failure (%)	ASTM D4632	50 minimum	50 minimum	50 minimum	50 minimum
Trapezoidal tear strength (pounds)	ASTM D4533	79 minimum	56 minimum	40 minimum	79 minimum
Puncture strength (pounds)	ASTM D6241	433 minimum	309 minimum	223 minimum	433 minimum
Ultraviolet light (retained strength) (%)	ASTM D4355	50 minimum	50 minimum	50 minimum	50 minimum
Permittivity (sec ⁻¹)	ASTM D4491		0.70 minimum or as specified		
Apparent opening size (AOS) (mm) ^{3/}	ASTM D4751		0.22 maximum or as specified		

1/ All values are minimum average roll values (MARV) in the weakest principal direction, unless otherwise noted.

2/ Needle punched geotextiles may be used for all classes. Heat-bonded or resin-bonded geotextiles may be used for class IV only.

3/ Maximum average roll value.

Specific Site Requirements

A. Measurement and Payment

1. Compensation for any work item described in the contract documents but not listed in the bid schedule will be included in the payment for the item of work to which it is made subsidiary. Such items and bid items to which they are made subsidiary are identified in the Items of Work and Construction Details section of the Special Specification. For any item described in the bid documents, not included in any bid item, or not made subsidiary to any bid item in the Items of Work, shall be made subsidiary to the Mobilization bid item.
2. Quantities used for progress payments shall be considered as only approximate and provisional and shall be subject to recalculation, adjustment, and correction by the engineer in subsequent payment applications. Inclusion of any quantities in a progress payment, or failure to disapprove the work at the time of any progress payment, shall not be construed as acceptance of the corresponding work or materials.
3. For items of work which Unit Prices are established in the contract, the quantity of work will be measured, estimated, or based on plan quantity. The determination of quantities of work performed under the contract will be made by the Engineer with the assistance of the contractor and will be based on lines and grades shown on the plans and as given during the progress of work or as evidenced by approved tickets for weight or liquid measure or by measurements made or approved by the engineer. The contractor will be paid based on the actual quantity of work completed and accepted.

B. Items of Work and Construction Details

1. Items of work to be performed in accordance with this specification and the construction details therefore are:
 - a. Subsidiary Item - Geotextile Fabric
 - (1) This item shall consist of furnishing and placing geotextile on all earth surfaces that contact the rock riprap or roadstone as shown on the drawings.
 - (2) Geotextile shall be Class I, nonwoven
 - (3) The geotextile shall be placed with the long dimension parallel to the channel.
 - (4) Geotextile shall not be measured and shall be considered subsidiary to Bid Item 11.