



STATE OF IOWA
MASTER AGREEMENT
 Contract Declaration and Execution

MA 005

16146A

EFFECTIVE BEGIN DATE: 12-15-2016
 EXPIRATION DATE: 12-14-2017
 PAGE: 1 of 3

VENDOR:

GL DODGE CITY LLC
Stew Hansens Dodge City

12103 Hickman Rd
Des Moines, IA 50323

VENDOR CONTACT:
 Harry Bougher
PHONE: 515-251-4234
EMAIL: harryb@stewhansens.com

ISSUER:
 Nancy Wheelock
PHONE: 515-725-2268
EMAIL: Nancy.Wheelock@iowa.gov

FOB: FOB Dest, Freight Prepaid

Contract For: Box Truck with Stowaway Lift Gate, 16 Foot

The parties agree to comply with the terms and conditions on the following attachments which are by this reference made a part of the Agreement.

Attachment 1: General Terms and Conditions for service/goods contracts are posted at: https://das.iowa.gov/sites/default/files/procurement/pdf/terms_goods.pdf

Attachments 2 thru 4 are on file with the Department of Administrative Services.

Attachment 2: Contractor's Response to Competitive Bidding RFB1116248095 (except for any contractor objection or amendment to the Competitive Bidding Document requirements that the State has not explicitly agreed to in writing)

Attachment 3: Bidders' Cost (final pricing documentation) response to competitive bidding document RFB1116248095.

Attachment 4: Special Terms
 See Vehicle Specifications Terms and Conditions attached.

RENEWAL OPTIONS

FROM 12-15-2017 **TO** 12-14-2018

AUTHORIZED DEPARTMENT

ALL
 SUB Other Governmental Entities

IN WITNESS WHEREOF, this Agreement has been executed by the parties hereto.

CONTRACTOR		STATE OF IOWA	
CONTRACTOR'S NAME (If other than an individual, state whether a corp, partnership, etc.)		AGENCY NAME	
BY (Authorized Signature)	Date Signed	BY (Authorized Signature)	Date Signed
Printed Name and Title of Person Signing		Printed Name and Title of Person Signing	
Address		Address	



STATE OF IOWA
MASTER AGREEMENT
 Contract Declaration and Execution

MA 005

16146A

EFFECTIVE BEGIN DATE: 12-15-2016
 EXPIRATION DATE: 12-14-2017
 PAGE: 2 of 3

LINE NO.	QUANTITY / SERVICE DATES	UNIT	COMMODITY / DESCRIPTION	UNIT COST / PRICE OF SERVICE
----------	--------------------------	------	-------------------------	------------------------------

1	0.00000	EA	07205	\$ 0.000000
				\$ 0.000000

REF DOC: REF VNDR LN: REF COMM LN: REF TYPE: FINAL

Class 5 Trucks (16,001 - 19,500 lb. GVWR)
16' Standard Cab Box Truck with Stowaway Lift Gate 4X2, DRW

16 Foot Standard Cab Box Truck with Stowaway Liftgate, 4X2, DRW, V8 Engine, per attached specifications.

Make: RAM
 Model Name: 4500
 Exact Model Name: DP4L66
 Trim Pkg Common Name: Tradesman
 Exact Trim: 27A
 Engine Code: ESB
 Transmission Code: DF3
 GVWR: 16,500
 Liftgate Capacity: 3000 pounds

A stowaway lift gate deduction option and a diesel engine upgrade option are available for this truck

Price delivered to DAS Fleet services is \$49,021.00. Delivery to all other locations within the state of Iowa is an additional \$0.25 per mile charge.

Price may vary depending upon options chosen.



STATE OF IOWA
MASTER AGREEMENT
Contract Declaration and Execution

MA 005

16146A

EFFECTIVE BEGIN DATE: 12-15-2016
EXPIRATION DATE: 12-14-2017
PAGE: 3 of 3

TERMS AND CONDITIONS

Goods Eff Feb 15

The parties agree to comply with the terms and conditions on the following web site which are by this reference made a part of the Agreement. General Terms and Conditions for goods contracts are posted at: https://das.iowa.gov/sites/default/files/procurement/pdf/51415%20terms_goods.pdf

NEW Standard Cab 4X2 DRW Box Truck, Stow Away Lift Gate, Automatic Transmission

Make:	RAM
Model Name:	4500
Exact Model Code:	DP4L66
Trim Pkg. Common Name:	TRADESMAN
Exact Trim Pkg. Code:	27A
Engine Code:	ESB
Transmission Code:	DF3

DEALER NAME: **STEW HANSEN DODGE CITY**

BASE VEHICLE SPECIFICATIONS		
Body & Chassis	Minimum Requirements	Mfg. Codes - Specs (Note STD for standard)
Gross Vehicle Weight Rating	12,500 lb. GVWR minimum	STATE GVWR: 16500
Box Body Specifications		
15 or 16 Foot Length, Aluminum Dry Freight	96 inch exterior width, nominal 92 inch inside width 102 inch inside height, nominal 111 inch exterior height Pre-painted white exterior panels, 0.40 inch thick minimum One piece roof panel, mill finish, 0.30 inch thick minimum Aerodynamically rounded front corners, nominal 12 inch horizontal across the top Top crossmembers on nominal 18 inch centers. No wheel cutouts Plywood lining. 1/2 inch on front, 3/8 inch on sides, 1/4 inch on ceiling. Smooth White 12 gauge smooth steel scuff liner 12 inches high front and sides E-track logistic channels on both sides and front Plastic coated full width roll-up rear door with grab handles Mud flaps behind rear wheels. Plain black with no vendor logo. Entire underside of body undercoated. Clearance lights and reflectors to meet all Federal Motor Vehicle Safety Standards. All illuminated lamps must be LED type. Two LED dome lamps inside body with switch and indicator in cab.	STATE LENGTH:16' Notes:
Engine		
Engine Size (Cylinder/Liter)	V8 or V10 Engine Gasoline Engine, minimum 5.4 L 250 HP	Cylinders: 8 Liters: 6.4 HP: 366 Torque:429
Engine Block Heater		MFG CODE: NHK
Drive Axle		
Rear Axle	Limited Slip / Locking Differential	STATE RATIO:4.44
Electrical		
Power Point	Located in Driver Area	STANDARD
Doors & Windows		
Doors	Power locks with remote keyless entry	MFG CODE: AJH
Key Sets with Fobs	2 extra sets. 4 total complete sets with each vehicle.	MFG CODE: DEALER
Windows	Power	MFG CODE: AJH
Wipers	Intermittent wipers. Variable speed, if available	STANDARD
Exterior		
Cab Paint Color	White	MFG CODE: PW7
Cab Steps	Cab steps, if applicable for chassis style, should be non-slip	MFG CODE: MRU
Cab Grab Handle	Located on outside of cab next to door for easy entry	AFTERMARKET
Mirrors	Trailer tow extendable mirrors	STANDARD
Floor		
Floor Covering	Full floor covering, rubber preferred - if available it must be provided. OEM Floor Mats only provided if floor covering must be carpet.	STANDARD
Interior		
Air Conditioning	AC with all required options.	STANDARD
Bluetooth	Factory preferred but dealer installed acceptable	MFG CODE:UA1 Factory installed?
Radio	AM/FM with internal clock	STANDARD
Steering Column	Tilt / Cruise Control. Telescoping, if available	STANDARD
Trim Package for Cab	Interior, with insulating headliner, full door and back of cab panels, dome lamp. Driver/Passenger high back seats w/cloth upholstery, armrest, and storage console.	MFG CODE:V9
Lift Gate Specifications		
THIEMAN STOW-AWAY or TOMMY GATE TUCKUNDER SERIES or approved alternative. Bidders should submit lift gate specification sheet(s) with bid.	Folding platform that stows underneath the truck: 84 inch wide by 40 inch deep with 8 inch ramp OR two piece, 80 inch wide by 50-inch deep wedge style. Automatic kickout arm to push platform to near 90 degree angle when platform is lowered, if applicable to lift gate brand. Capacity: 3,000 lbs. Wide arm design with 2 hydraulic cylinders. Self-contained 12 volt electric/hydraulic unit with cover to protect it from road spray and weather. Heavy duty rubber dock bumpers. Cab mounted master shut-off switch for safety and to prevent unauthorized use. Control handle kit to allow outside or inside mounting of control handle. Line fuse to protect 12 volt system. Lift painted dark color to match truck frame. Fully greased, serviced and tested before delivery.	MFG CODE: TKT-80-30-TP50 Notes: 3000# CAPACITY, ELECTRIC/HYDRAULIC POWER UNIT W/ ENCLOSURE, STANDARD CURB-SIDE FIXED CONTROL INCLUDES: TOGGLE STYLE SWITCH, TIMER DEACTIVATES 5 MIN AFTER LAST OPERATION, DUAL LIFT CYLINDERS FOR EVEN LIFTING, POWER DOWN OPERATION
Safety		
Brakes	Power 4 Wheel Anti-lock	STANDARD
Daytime Running Lights	If available	MFG CODE:LM1
Backup Alarm	Factory preferred but dealer installed acceptable	AFTERMARKET
Tires & Wheels		
Tires	All Season Radial.	STANDARD

Spare	Full Size Spare to be installed in a frame mounted locking carrier under the box body. 2 keys for the lock.	MFG CODE:TBB
BASE VEHICLE PRICE CONFIGURED AS PER ABOVE:		\$49,021.00
Delivery Cost to Department of Administrative Services, Des Moines:		\$0.00
TOTAL VEHICLE PRICE INCLUDING BOX, LIFT GATE, AND DELIVERY:		\$49,021.00

NEW Standard Cab 4X2 DRW Box Truck, Stow Away Lift Gate, Automatic Transmission

STEW HANSEN DODGE CITY

ADDITIONAL OPTIONS			
Engine	Minimum Requirements	Mfg. Codes - Specs (Note STD for standard)	Cost
Engine Size (Cylinder/Liter)	V8 or V10 Engine Gasoline Engine, minimum 5.4L 250 HP		DEDUCT: N/A
Engine Upgrade	Turbocharged Diesel, minimum 6.6L displacement - Must be rated minimum 350 HP, minimum 750 lb./ft. torque with HD automatic transmission. Include all required options and other pertinent information.	Cylinders: 6 Liters: 6.7 HP: 325 Torque: 725 OTHER REQUIREMENTS:	IST \$8,650.00
Lift Gate - Stowaway	Per attached specifications		DEDUCT: -\$6,000.00
Bumper	Steel	MFG CODE:	STANDARD
Floor			
Floor Covering	Full floor carpeting & OEM mats, if not provide in base above.	MFG CODE:CKE	\$128.00

DELIVERY			
Delivery FOB	Price per mile to deliver vehicle anywhere in State of Iowa		Per Mile Charge \$0.25
Delivery Cost	Delivery Cost to Department of Administrative Services, in Des Moines, IA	Enter miles in whole number:	0.00 \$0.00



QUOTE NO.:67572
 Date:12/07/15
 EXPIRES:12/21/15
 Page: 1

1560 NE 44TH AVENUE
 P.O. BOX 3265
 DES MOINES IA 50316

Sales & Service (515)266-5189 Fax (515)266-7878 Wats (800)373-2887

Q U O T A T I O N

TO: STEW HANSEN DODGE CITY
 12103 HICKMAN RD

 DES MOINES IA 50323

 HARRY BOUGHER /RE: DAS

TRUCK INFORMATION

Year: 2016 WB: 0
 Truck Make:DODGE CA: 120
 Model:3500 Trans:
 Color:WHITE
 VIN NO.:

VA16-96 US TRUCK BODY VAN BODY

FURNISH AND INSTALL:

1 US TRUCK BODY MODEL VA16-96 ALUMINUM VAN BODY

FEATURES AND SPECIFICATIONS

Inside length: 16' Inside height: 96"
 Pre-painted panels (.40) in "Polar White"
 One-piece roof (.30) mill finish w/ roof bows on 18" centers
 "Zephyr" front
 "Z" posts on 16" centers
 Solid sides, Plywood full height
 Stainless steel rear frame
 1-1/8" laminated hardwood floor with 2 screws per plank per crossmember
 Crossmembers on 12" centers (approx.)
 Plywood lining: 1/2" front, 3/8" sides
 One dome light in roof with switch inside rear of body
 LED clearance lights and reflectors to meet FMVSS#108
 Full undercoating
 Mud flaps behind rear wheels

Options included in price-
 Plastic covered rollup rear door w/ 84.5" clear opening height - prepainted white to match body
 One grab handle on each side at rear
 Two rows of recessed E-track on front and sides - PLEASE SPECIFY HEIGHT FROM FLOOR TO CENTER OF TRACK!
 12"H x 12 ga. smooth scuff plate on front and sides
 NOTE: FRONT SCUFF PLATE IS DROPPED BELOW FLOOR LEVEL AND WELDED TO FRONT UNDERSTRUCTURE TO FURTHER REINFORCE THE FRONT WALL!
 Two LED domelights w/ switch at rear and lighted indicator switch in cab
 1/4" Duro-lam lining on ceiling (white finish)
 Curbside mounted spare tire carrier w/ chain and padlock w/ two keys for securing spare tire
 Transportation of drop-shipped chassis from Streator,IL to Des Moines

*** CONTINUED NEXT PAGE ***

TKT FEATURES

Tuckunder Series

The Tommy Gate Tuckunder Series offers large platforms and high lifting capacities while also providing the convenience of folding and storing underneath the vehicle bed. Available with both treadplate steel and extruded aluminum platforms, these lifts are the most popular style of liftgates on the market.

Included Features

- 1 **LARGE, RUBBER DOCK BUMPERS**
protect the bed extension
- 2 **UNDERRIDE IMPACT GUARD**
protects from rear vehicle underride
- 3 **FULLY-ENCLOSED POWER UNIT**
protects hydraulic pump and motor

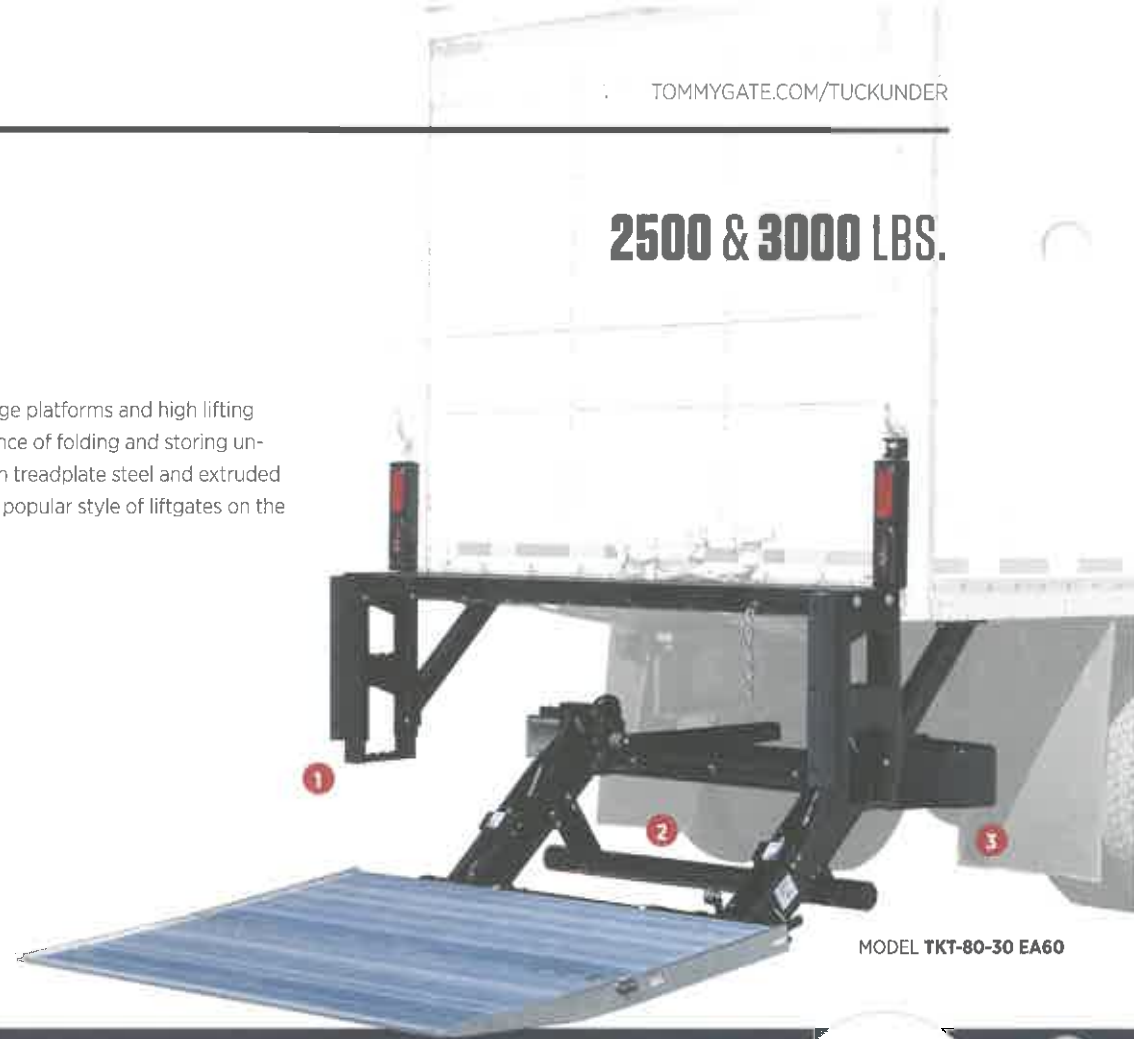

2500 & 3000 LBS.

MODEL TKT-80-30 EA60

TKT models address all the concerns a liftgate operator faces. With self-leveling and power down functions, the lift is simple to use and reliable. The large platforms easily accommodate pallet-sized loads. And, the wide-arm, dual-cylinder design assures sturdy and consistent lifting action.

NEW LOW-PROFILE CONTROL
SIMPLIFIES LIFTGATE OPERATION



MODEL TKT-80-30 EA60



TOMMY GATE®

TOMMY GATE® QUALITY

Like all Tommy Gate hydraulic lifts, the main assembly of the Tuckunder Series is cut from raw steel, formed into precision parts, and hand-welded. TKT models are then painted before assembly to reduce exposure and corrosion. This entire process is completed on site at the Tommy Gate factory in Woodbine, Iowa. To learn more about Tommy Gate and the Tuckunder Series, visit tommygate.com



TKT AT A GLANCE

-  Power-Down
-  Dual-Cylinder
-  Self-Leveling
-  Wedge Platform

FULLY PROTECTED
HYDRAULIC SYSTEM



MODEL TKT-80-30 TP60

Liftgate Function (SIDE VIEW)

- 1 Platform lowers away from bed level
- 2 Platform remains level at mid-travel
- 3 Platform is level when 'knuckle' is at ground level
- 4 A secondary function tilts the platform loading edge to ground level (self-leveling)

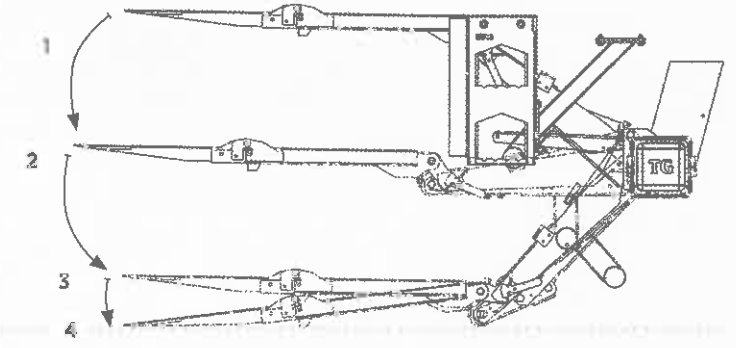

GROUND LEVEL

LIFTGATE "KNUCKLE"

TOMMY GATE

Available Models (DUAL-CYLINDER, POWER-DOWN, SELF-LEVELING)

TWO-YEAR STANDARD WARRANTY

	Model Number	Load Area	Bed Heights	Gate Weight ¹
2500 lb. Capacity	<u>Treadplate Platforms</u>			
	TKT-80-25 TP50	80 x 50	40-54	887
	TKT-80-25 TP60	80 x 60	45-54	980
	<u>Aluminum Platforms</u>			
	TKT-80-25 EA50	80 x 50	40-54	971
	TKT-80-25 EA60	80 x 60	45-54	1021
3000 lb. Capacity	<u>Treadplate Platforms</u>			
	TKT-80-30 TP50	80 x 50	40-54	887
	TKT-80-30 TP60	80 x 60	45-54	980
	<u>Aluminum Platforms</u>			
	TKT-80-30 EA50	80 x 50	40-54	971
	TKT-80-30 EA60	80 x 60	45-54	1021

Available Bed Extension Options

Body Size	Extension Type	Extension Weight	Description
96"	Standard	276	"standard" strength 3/16-inch thick steel construction
96"	Heavy Duty	334	"heavy duty" strength 3/8-inch thick steel construction
102"	Standard	283	"standard" strength 3/16-inch thick steel construction
102"	Heavy Duty	341	"heavy duty" strength 3/8-inch thick steel construction

Features & Options

Option	Description
<p><u>Standard Features</u></p> <p>Rubber Dock Bumpers protect the bed extension from direct contact with loading dock surface</p> <p>Underride Impact Guard a low, full-width guard bar protects from rear vehicle underride</p> <p>Platform Power Down offers consistent platform action both upwards and downwards</p> <p>Fixed Toggle Control a low-profile control with five-minute inactivity shut-off</p> <p>Snubber Kit secures the platform when stored</p> <p>Standard Power Cable 38-foot, 2-gauge, full-length power and ground</p> <p><u>Additional Options</u></p> <p>Split Cart Stops* secure wheeled cargo, aluminum platforms only</p> <p>2-light, LED Light Kit 2-light add-on system (T-80) (one red, one white each side)</p> <p>Dual Controls standard fixed control + remote pendant control</p> <p>Extended Power Cable 41-foot cable, 2-gauge, full-length power and ground</p> <p>24-volt System compatible with vehicles running a 24-volt system</p> <p>License Plate Mount bracket plate holder with light</p> <p>In-Line Power Shut-Off disables power to the liftgate along the power line</p> <p>In-Cab, Shut-off Switch disables power to the liftgate from within the truck cab</p>	

* Aluminum platforms lose 10 inches of loading depth when cart stops are deployed.



Woodbine Manufacturing Inc.
 83 Bus Brown Drive
 Woodbine, IA 51579

TOMMY GATE® LIFTGATES
 (800) LIFTGATE
 TOMMYGATE.COM



Standard

Aluminum & FRP Van Features

Front	Heavy-duty 7 post construction on VA models. Aerodynamic design, aluminum "Zephyr" front nose, aluminum corner castings (not fiberglass), 5" corner radius utilizing 1/8" rugged aluminum extrusion.
Walls	Aluminum (.040 in.) panels, pre-painted white, baked enamel or 5/8" core thickness FRP panels with 18 oz. woven fiberglass, gel-coated finish, impregnated white.
Posts	"Z" shaped high strength extruded aluminum posts (Not Steel) are positioned on 16" centers on all VA models.
Roof	One-piece aluminum (.032 in.), tension-fitted and bonded to roof bows, perimeter riveted. Roof assembly bolted to top rail structure for easy removal and repair.
Roof Bows	Roll-formed 18 gauge galvanized steel, anti-sag configuration, located on 24" centers.
Rear Frame	11 gauge (1/8" nominal thickness) galvanneal steel with reinforcement at all stress points. Tapered rear threshold.
Doors	Custom built side or rear swing doors to ensure a precise fit and positive closing, with quality 13 mm thick DuraPlate exterior skin construction.
Hinges	Heavy-duty extruded aluminum side and rear door hinges for long term use with stainless steel replaceable pins.
Bar Locks	All stainless steel hardware on rear swing doors.
Crossmembers	Hi-tensile 3" steel I-beam construction on 12" centers. Each crossmember is double bolted at each end to the heavy-duty extruded aluminum rubrail. Alternating crossmembers are gusseted to longitudinals with steel wheel pan supports over the wheels.
Longitudinals	Structural steel "C" channel (height dependent on chassis mounting requirements).
Floor	1 1/8" laminated hardwood, each board installed with two 5/16" countersunk screws at each crossmember and securely joined to adjacent boards by shiplap joints and an added crusher bead to ensure a tight seal.
Lining	3/8" plywood on sides and 1/2" plywood on front wall for Aluminum vans.
Interior Light	Roof-mounted dome light, recessed switch in wall inside rear door opening.
Exterior Lights	Marker lights recessed in roof cove with exterior wiring in protective groove. All connectors shielded from moisture by heat-shrink insulators.
Reflectors	Installed as required to comply with FMVSS.
Undercoating	Petrol base (not paint) on full understructure.
Mounting	Body mounted on customer-supplied chassis. Hardwood filler strips are steel-banded to top of chassis frame rails. Zinc plated U-bolts are placed through crush pipes (between frame rails) to hold body in place more securely and to prevent over-tightening and bending of frame rails. Structural steel "side-standards" are welded to longitudinals to prevent shifting side-to-side.
Mudflaps	"U.S. Truck Body"



Standard

Van Body Specifications

Aluminum Van Body

Standard Length (Inside) 10' - 28'
 (Outside length is 6 3/8" longer than inside dimension.)
 Custom sizes available.

Notes: A. Inside length based on 1/2" plywood lining on front wall,
 and roll-up rear door.

B. For full rear swing-type doors, add 3 1/2" to inside body length.



Standard Width and Height

MODEL #	INSIDE		OUTSIDE		REAR DOOR OPENING	
	Width	Height	Width	Height	Width	Height
VA-78	93"	78"	96"	85"	88"	72 1/2"
VA-84	93"	84"	96"	91"	88"	78 1/2"
VA-90	93"	90"	96"	97"	88"	84 1/2"
VA-96	93"	96"	96"	103"	88"	90 1/2"
VA-102	93"	102"	96"	109"	88"	96 1/2"
VA-108	93"	108"	96"	115"	88"	102 1/2"

Notes: C. Inside width is measured from post-to-post without lining. Add 6" for 102" wide O.D.

D. Outside height of body is measured excluding longitudinals.

E. Rear door openings are same for roll-up or swing type doors.

FRP Van Body

Standard Length (Inside) 10' - 28'
 (Outside length is 6 3/8" longer than inside dimension.)
 Custom sizes available.

Notes: A. Inside length measured from inside front FRP panel to
 inside surface of roll-up rear door.

B. For full rear swing-type doors, add 3 1/2" to inside body length.



Standard Width and Height

MODEL #	INSIDE		OUTSIDE		REAR DOOR OPENING	
	Width	Height	Width	Height	Width	Height
VF-78	94 1/4"	78"	96"	85"	88"	72 1/2"
VF-84	94 1/4"	84"	96"	91"	88"	78 1/2"
VF-90	94 1/4"	90"	96"	97"	88"	84 1/2"
VF-96	94 1/4"	96"	96"	103"	88"	90 1/2"
VF-102	94 1/4"	102"	96"	109"	88"	96 1/2"

Notes: C. Outside height of body is measured excluding longitudinals.

D. Rear door openings are same for roll-up or swing type doors.